

# Alternatives Technical Report

Prepared in Support of the Supplemental Environmental Impact Statement

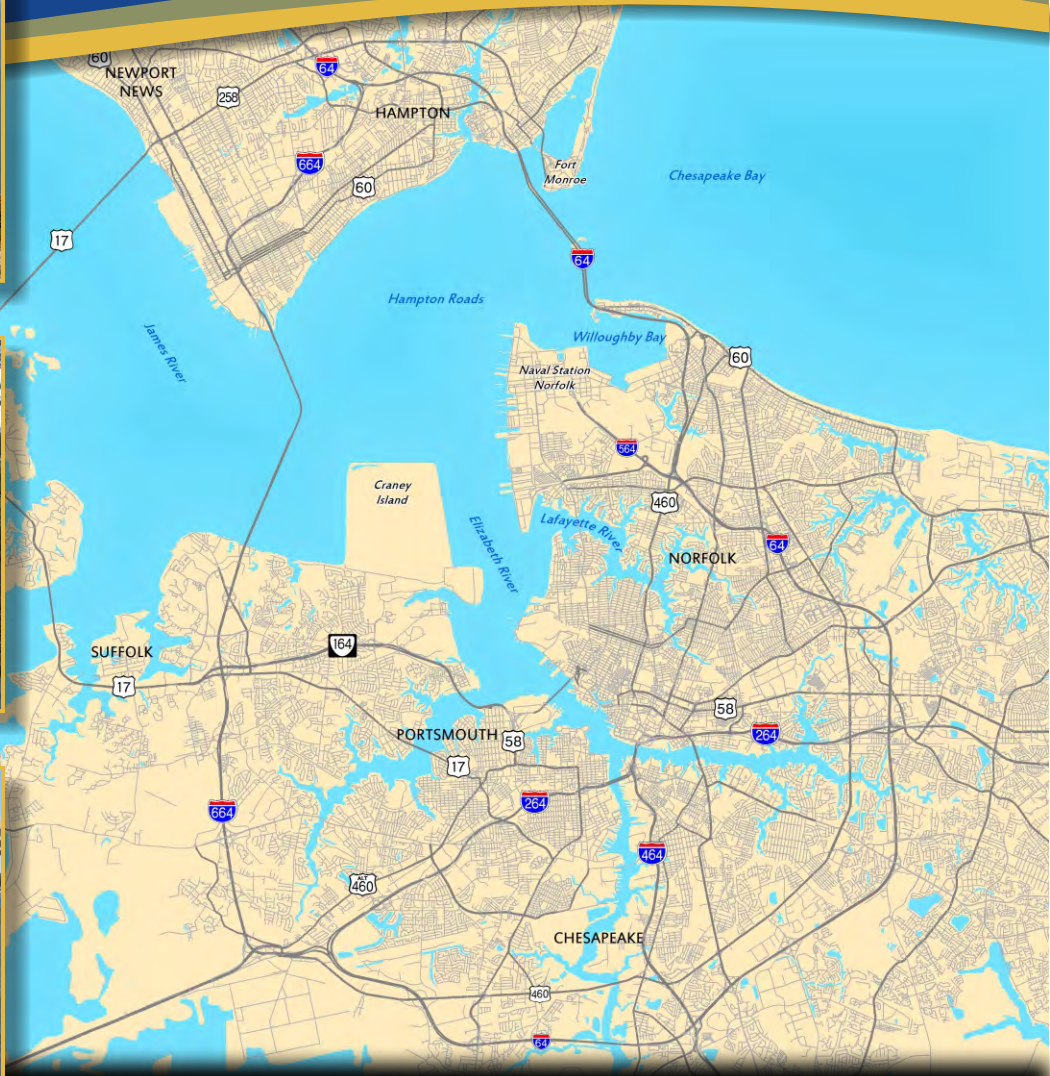
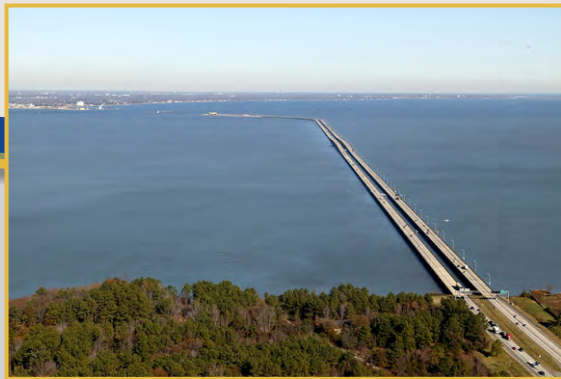

# ALTERNATIVES TECHNICAL REPORT

## **HRC** **SEIS** Hampton Roads Crossing Study SEIS



Prepared in support of the Supplemental Environmental Impact Statement

VDOT Project #: 0064-965-081, P101

UPC#: 106724

**July 2016**

**TABLE OF CONTENTS**

**1. INTRODUCTION.....1**

    1.1 Project Description..... 1

    1.2 Purpose and Need..... 3

**2. EXISTING CONDITIONS .....3**

    2.1 Interstate 64..... 3

    2.2 Interstate 664..... 8

    2.3 Interstate 564..... 14

    2.4 Virginia Route 164..... 18

**3. PREVIOUS STUDIES.....20**

    3.1 HRCS FEIS (2001) ..... 20

    3.2 2003 FEIS Re-evaluation..... 20

    3.3 2011 EA Re-evaluation ..... 20

    3.4 HRBT (2012)..... 20

    3.5 2013 EA Re-evaluation ..... 21

**4. ALTERNATIVES PREVIOUSLY CONSIDERED.....21**

    4.1 Major Investment Study (1997) ..... 21

    4.2 HRCS FEIS (2001) ..... 21

    4.3 HRBT (2012)..... 23

    4.4 Verification For Not Retaining Previous Alternatives in this SEIS ..... 26

    4.5 Improvements Identified During Scoping ..... 27

**5. ALTERNATIVES DEVELOPMENT AND EVALUATION PROCESS.....28**

    5.1 Accommodate Travel Demand..... 29

    5.2 Improve Transit Access..... 29

    5.3 Increase Regional Accessibility..... 29

    5.4 Address Geometric Deficiencies..... 30

    5.5 Enhance Emergency Evacuation Capability..... 30

    5.6 Improve Strategic Military Connectivity..... 31

    5.7 Increase Access to Port Facilities..... 31

**6. DESIGN CRITERIA .....31**

**7. ALTERNATIVES .....34**

    7.1 No-Build Alternative..... 34

    7.2 Build Alternatives ..... 34

**8. ALIGNMENT SEGMENTS .....44**

8.1	Interstate 64 .....	46
8.2	Interstate 664 .....	51
8.3	Interstate 664 Connector .....	57
8.4	Interstate 564 and Interstate 564 Connector .....	63
8.5	Virginia Route 164 Connector .....	67
8.6	Virginia Route 164 .....	69
<b>9.</b>	<b>OPERATIONALLY INDEPENDENT SECTIONS.....</b>	<b>72</b>
9.1	Potential Hybrid Alternatives .....	74
9.2	Phased Implementation Approach.....	74
9.3	Order of Implementation .....	74
<b>10.</b>	<b>ENGINEERING DETAILS OF ALTERNATIVES RETAINED.....</b>	<b>76</b>
10.1	Roadside Design and Limits of Disturbance .....	76
10.2	Bridge and Tunnel Limits of Disturbance .....	79
10.3	Interchanges.....	79
10.4	Other Proposed Interchanges .....	80
10.5	Landside Structures.....	80
10.6	Approach Bridges to Tunnels .....	89
10.8	Tunnels .....	92
10.9	Truck Weigh and Inspection Stations .....	94
<b>11.</b>	<b>PRELIMINARY COST ESTIMATES.....</b>	<b>94</b>

**LIST OF TABLES**

Table 4-1:	Verification for Not Including in SEIS.....	26
Table 6-1:	Mainline Design Criteria .....	32
Table 6-2:	Interchange Design Criteria .....	33
Table 6-3:	Structural Design Parameters.....	34
Table 7-1:	Alternative A Lane Configurations.....	35
Table 7-2:	Alternative A Alignment Segments.....	35
Table 7-3:	Alternative B Lane Configurations .....	37
Table 7-4:	Alternative B Alignment Segments.....	37
Table 7-5:	Alternative C Lane Configurations .....	39
Table 7-6:	Alternative C Alignment Segments.....	40
Table 7-7:	Alternative D Lane Configurations.....	42
Table 7-8:	Alternative D Alignment Segments.....	42
Table 8-1:	Alignment Segments.....	44
Table 9-1:	Operationally Independent Sections .....	72
Table 9-2:	Alternative A Order of Implementation.....	75
Table 9-3:	Alternative B Order of Implementation.....	75
Table 9-4:	Alternative C Order of Implementation.....	75
Table 9-5:	Alternative D Order of Implementation .....	75
Table 10-1:	Roadside Design Options.....	77
Table 10-2:	I-64 Existing Landside Structures Impacted by Proposed Improvements.....	81
Table 10-3:	Structures Crossing Over I-64 Impacted by Proposed Improvements.....	81
Table 10-4:	I-664 Existing Landside Structures Impacted by Proposed Improvements.....	83
Table 10-5:	Structures Crossing Over I-664 Impacted by Proposed Improvements.....	85
Table 10-6:	Proposed I-664 Landside Structures .....	85
Table 10-7:	Proposed I-564 Connector Structures.....	86
Table 10-8:	VA-164 Existing Landside Structures Impacted by Proposed Improvements.....	87
Table 10-9:	Structures Crossing over VA 164 Impacted by Proposed Improvements .....	87
Table 10-10:	Proposed VA 164 Landside Structures.....	88
Table 11-1:	Preliminary Construction Cost Estimates .....	94

**LIST OF FIGURES**

Figure 1-1: Study Area Corridors..... 2

Figure 2-1: I-64 Study Area Corridor ..... 4

Figure 2-2: I-64 Study Area Corridor, continued..... 5

Figure 2-3: I-64 Study Area Corridor, continued..... 6

Figure 2-4: I-664 Study Area Corridor ..... 9

Figure 2-5: I-664 Study Area Corridor, continued..... 10

Figure 2-6: I-664 Study Area Corridor, continued..... 11

Figure 2-7: I-664 Study Area Corridor, continued..... 12

Figure 2-8: I-564 Study Area Corridor ..... 15

Figure 2-9: I-564 Study Area Corridor, continued..... 16

Figure 2-10: I-564 Study Area Corridor, continued ..... 17

Figure 2-11: VA 164 Study Area Corridor ..... 19

Figure 7-1: Alternative A Lane Configurations ..... 36

Figure 7-2: Alternative B Lane Configurations ..... 38

Figure 7-3: Alternative C Lane Configurations ..... 41

Figure 7-4: Alternative D Lane Configurations..... 43

Figure 8-1: Alignment Segments..... 45

Figure 8-2: I-64 No-Build Typical Sections ..... 47

Figure 8-3: I-64 Proposed Typical Sections ..... 48

Figure 8-4: Existing Willoughby Bay Bridge Typical Section Looking Eastbound ..... 50

Figure 8-5: Proposed Willoughby Bay Bridge Typical Section Looking Eastbound ..... 50

Figure 8-6: I-664 No-Build Typical Sections ..... 52

Figure 8-7: I-664 Alternative C Proposed Typical Sections ..... 53

Figure 8-8: I-664 Alternative D Proposed Typical Sections..... 54

Figure 8-9: I-664 Connector Alternative C and D Typical Sections ..... 58

Figure 8-10: I-664 / I-664 Connector Interchange, Alternative C..... 60

Figure 8-11: I-664 / I-664 Connector Interchange, Alternative D..... 62

Figure 8-12: I-564 Connector Alternative C Typical Sections ..... 64

Figure 8-13: I-564 Connector Alternatives B and D Typical Sections ..... 65

Figure 8-14: VA 164 Connector Typical Sections ..... 68

Figure 8-15: VA 164 No-Build Typical Sections..... 70

Figure 8-16: VA 164 Proposed Typical Sections..... 71

Figure 9-1: Operationally Independent Sections ..... 73

Figure 10-1: Roadside Design Options..... 78

Figure 10-2: I-64 Approach Bridges to Tunnels Typical Section ..... 90

Figure 10-3: I-664 Approach Bridge to Tunnels Typical Section..... 91

**LIST OF APPENDICES**

- Appendix A: Alternatives Mapping
- Appendix B: Cost Estimate Methodology
- Appendix C: Cost Estimates
- Appendix D: 3-4-3 Analysis

## **1. INTRODUCTION**

### **1.1 PROJECT DESCRIPTION**

The Virginia Department of Transportation (VDOT), in cooperation with the Federal Highway Administration (FHWA) as the lead federal agency, is preparing a Supplemental Environmental Impact Statement (SEIS) for the Hampton Roads Crossing Study (HRCS) located in the cities of Chesapeake, Hampton, Newport News, Norfolk, Portsmouth, and Suffolk, Virginia. The SEIS re-evaluates the findings of the 2001 HRCS Final Environmental Impact Statement (FEIS) and Record of Decision (ROD). The three alternatives retained for analysis in the 2001 FEIS, as well as input received from the public during initial scoping for the SEIS, were used to establish the Study Area Corridors shown in **Figure 1-1**.

Pursuant to the National Environmental Policy Act (NEPA) of 1969, as amended, FHWA is preparing an SEIS because of the time that has lapsed since the 2001 FEIS and new information indicating significant environmental impacts not previously considered. Prepared in accordance with the implementing regulations of NEPA (23 CFR §771.130), the SEIS is intended to aid in ensuring sound decision-making moving forward by providing a comparative understanding of the potential effects of the various options.

The purpose of this Technical Report is to describe the alternatives development process and screening criteria approach for the SEIS, including the identification of an initial range of alternatives considered and alternatives retained for detailed evaluation. With the exception of the No-Build Alternative, Build Alternatives that do not address the stated purpose and need were determined to be not reasonable and were not advanced for detailed evaluation. The remaining alternatives were retained for detailed evaluation and environmental analysis. Information in this report, described below, will support discussions presented in the SEIS.

- **Section 1** provides an overview of the study.
- **Section 2** provides an overview of existing conditions.
- **Section 3** describes the previous studies.
- **Section 4** describes the alternatives previously considered.
- **Section 5** describes the alternatives development process.
- **Section 6** provides the design criteria used in the development of the alternatives.
- **Section 7** describes the alternatives.
- **Section 8** describes the alignment segments.
- **Section 9** describes the operationally independent sections, and a potential phased implementation approach.
- **Section 10** describes the engineering details of the Retained Alternatives, including the limit of disturbance, the roadside design, interchanges, landside structures, approach bridges to tunnels, and the tunnels.
- **Section 11** includes the preliminary cost estimates.



Figure 1-1: Study Area Corridors

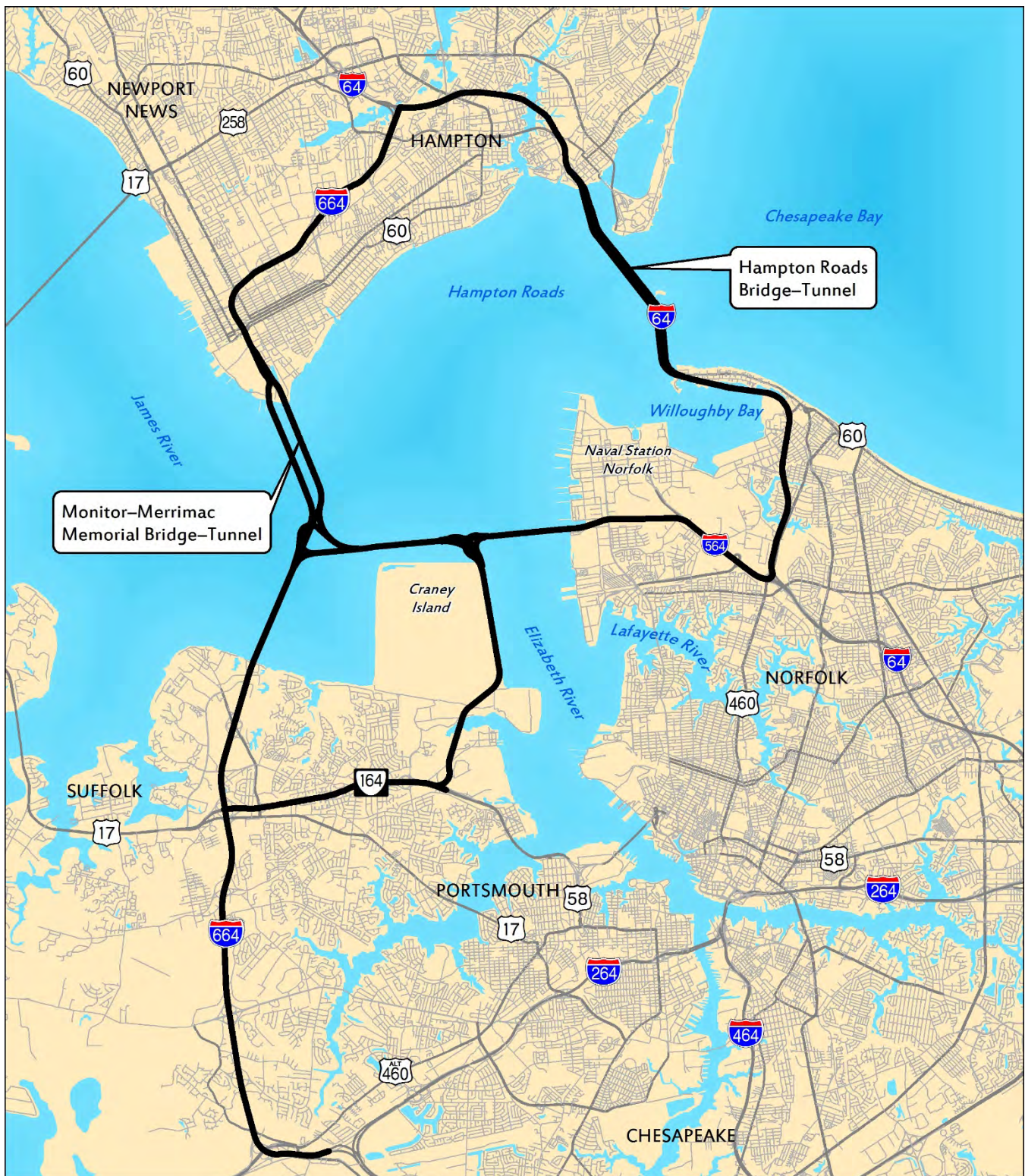

Legend

— Study Area Corridors

— Major Roads

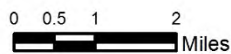

**HRCs SEIS**  
Hampton Roads Crossing Study SEIS

**Study Area  
Corridors**

## 1.2 PURPOSE AND NEED

The purpose of the HRCS is to relieve congestion at the Interstate 64 (I-64) Hampton Roads Bridge-Tunnel (HRBT) in a manner that improves accessibility, transit, emergency evacuation, and military and goods movement along the primary transportation corridors in the Hampton Roads region, including the I-64, I-664, I-564, and VA 164 corridors. The HRCS will address the following needs (in the order of presentation in Chapter 1 of the Draft SEIS):

- Accommodate travel demand – capacity is inadequate on the Study Area Corridors, contributing to congestion at the HRBT;
- Improve transit access – the lack of transit access across the Hampton Roads waterway;
- Increase regional accessibility – limited number of water crossings, inadequate highway capacity and severe congestion decrease accessibility;
- Address geometric deficiencies – insufficient vertical and horizontal clearance at the HRBT contribute to congestion;
- Enhance emergency evacuation capability – increase capacity for emergency evacuation, particularly at the HRBT;
- Improve strategic military connectivity – congestion impedes military movement missions; and
- Increase access to port facilities – inadequate access to interstate highway travel in the Study Area Corridors impacts regional commerce.

## 2. EXISTING CONDITIONS

### 2.1 INTERSTATE 64

The portion of the I-64 Study Area Corridor extends from 1.7 miles west of the I-664 interchange in Hampton to the I-564 interchange in Norfolk, a distance of approximately 14 miles, including the 3.5-mile long Hampton Roads Bridge-Tunnel (HRBT). I-64 consists of three main geographic regions within the Study Area Corridor, the Peninsula (Hampton), the HRBT, and the Southside (Norfolk). The posted speed limit is 55 miles per hour (mph). The I-64 Study Area Corridor is shown in **Figures 2-1** through **2-3**.

Figure 2-1: I-64 Study Area Corridor



Legend

- - - Alternative Alignment on Existing Roadway
- Alternative Alignment on New Location
- Major Roads

0 0.15 0.3 0.6 Miles



**HRCS SEIS**  
Hampton Roads Crossing Study SEIS  
**I-64 Study Area Corridor**

**Figure 2-2: I-64 Study Area Corridor, continued**



**Legend**

-  Alternative Alignment on Existing Roadway
-  Alternative Alignment on New Location
-  Major Roads



**HRCS SEIS**  
Hampton Roads Crossing Study SEIS  
**I-64 Study Area Corridor**

Figure 2-3: I-64 Study Area Corridor, continued



Legend

- - - Alternative Alignment on Existing Roadway
- Alternative Alignment on New Location
- Major Roads

0 0.125 0.25 0.5 Miles



**HRCS SEIS**  
Hampton Roads Crossing Study SEIS

**I-64 Study Area Corridor**

### 2.1.1 Hampton

Within Hampton, I-64 is predominantly three lanes in each direction with acceleration, deceleration, and auxiliary lanes. The mainline typical section generally includes 12-foot travel lanes, 12-foot right shoulders, and 4-foot left shoulders. Northbound and southbound traffic are separated by a concrete barrier. The lane and right shoulder widths meet current American Association of State Highway and Transportation Officials (AASHTO) and VDOT interstate design standards; however, the six-to ten-foot left shoulder width does not meet current design standards per the *Policy on Geometric Design of Highways and Streets* (AASHTO, 2011), which is ten to 12 feet.

In the eastbound direction, the three lanes are reduced to two lanes at the Settlers Landing Road interchange (Exit 267) north of the HRBT. This lane reduction exacerbates the bottleneck at the tunnel due to reduced capacity. In the westbound direction, the two lanes from the HRBT widen to three lanes at the South Mallory Street interchange (Exit 268).

The following interchanges are located in Hampton:

- Exit 264 – I-664
- Exit 265 – VA 167/VA 134/LaSalle Avenue, North Armistead Avenue, and Rip Rap Road
- Exit 267 – US 60/VA 143/Settlers Landing Road and Woodland Road
- Exit 268 – VA 169/South Mallory Street

### 2.1.2 Hampton Roads Bridge-Tunnel

The 3.5-mile HRBT connects Hampton and Norfolk by spanning the Hampton Roads Harbor. The structure is composed of the 3,225-foot long western approach bridges, two 1.4-mile long parallel tunnels, and 5,925-foot long eastern approach bridges with 0.15-mile portal islands at the transitions between the bridges and the tunnels. The westbound span was opened to traffic in 1957 and the eastbound span was opened to traffic in 1976.

The bridges primarily consist of 75-foot long spans with a deck width of 44 feet. The bridge superstructure consists of simple span AASHTO prestressed beams and cast-in-place concrete deck. The bridge piers are constructed with a concrete cap supported on either 24-inch prestressed concrete piles or 54-inch prestressed concrete cylindrical piles.

The approach bridges between the tunnels and the land-side roadways have 12-foot wide lanes with 10-foot wide right shoulders and 4-foot wide left shoulders. The shoulders do not meet current AASHTO design standards. Additionally, the existing elevations of the bottom of the girders on the bridges is 10.35 feet relative to North American Vertical Datum [NAVD], which does not meet the clearance specifications in the *AASHTO Guide Specifications for Bridges Vulnerable to Coastal Storms* (2009).

The two existing tunnels are double shell steel, immersed tube tunnels. The westbound tunnel has 12-foot wide lanes and no shoulders. The vertical clearance is 13 feet 6 inches, which does not meet AASHTO or VDOT standards (AASHTO, 2011) (VDOT, 2015). AASHTO minimum vertical clearance is 16 feet, while VDOT requires 16 feet 6 inches for resurfacing activities. The vertical clearance is problematic for some trucks. According to the *VDOT Annual Traffic Stoppage Report* (2015), on the westbound HRBT over 1,600 trucks a year in 2015, or more than four trucks per day, were forced to turn around and use the higher clearance eastbound tunnel. When turnarounds occur, traffic has to be stopped in both directions. All traffic is stopped when trucks are pulled from I-64 for inspection and then stopped again to allow trucks to reenter I-64 following inspection.

The eastbound tunnel has 12-foot wide lanes and no shoulders. The vertical clearance is 14 feet 6 inches, which does not meet AASHTO or VDOT standards (AASHTO, 2011) (VDOT, 2015). AASHTO minimum vertical clearance is 16 feet, while VDOT requires 16 feet 6 inches for resurfacing activities. The clearance does not appear to be problematic because there is not a history of overheight trucks being stopped eastbound. No trucks were stopped in the eastbound direction in 2015 (VDOT, 2015).

### 2.1.3 Norfolk

In Norfolk, I-64 has two lanes per direction. The travel lanes are 12 feet wide, right shoulders are 12 feet wide and left shoulders vary from 2 to 6 feet wide. The median is approximately 44 feet wide and is a grass open section; however, it narrows down to approximately 31 feet wide approaching I-564. The lane and right shoulder widths meet current AASHTO design standards; however, the left shoulder width does not meet current AASHTO and VDOT interstate design standards, which is ten to 12 feet. I-64 is on structure across Willoughby Bay south of the West Ocean View Avenue/Bayville Street interchange; over wetlands surrounding West Ocean View Avenue/West Bay Avenue; and across Mason Creek south of West Bayview Boulevard where an entrance ramp is provided for Granby Street. The Willoughby Bay Bridges are 4,991 feet long and have a similar design to the HRBT approach bridges. They have a deck width of 44 feet and most spans are approximately 63 feet long. The bridge superstructure consists of prestressed concrete beams and cast-in-place concrete deck. The deck was built continuous for live loading to minimize the number of deck joints. The substructure consists of 24 inch square prestressed piles and pile cap.

The following interchanges are located in Norfolk:

- Exit 272 – VA 168/West Ocean View Avenue/Bayville Street
- Exit 273 – US Route 60/4th View Street
- Exit 274 – Entrance ramp from eastbound West Bay Avenue to I-64 east and exit ramp from westbound I-64 to westbound West Ocean View Avenue
- Westbound Entrance Ramp from Granby Street to I-64 just north of Norfolk Naval Station Gate 22 and the Forest Lawn Cemetery
- Eastbound Entrance Ramp from Norfolk Naval Station Gate 22 to I-64
- Exit 276 – I-564 and Granby Street (US Route 460) (southbound Granby Street cannot be accessed from westbound I-64 and northbound Granby Street is not accessible from eastbound I-64)

## 2.2 INTERSTATE 664

The I-664 Study Area Corridor includes the entire length of I-664. I-664 originates at the I-64 interchange in Hampton on the Peninsula, continues south through the City of Newport News, crosses Hampton Roads Harbor through the Monitor-Merrimac Memorial Bridge-Tunnel (MMMBT), continues primarily south through the cities of Suffolk and Chesapeake, and ends at the I-264 interchange in the City of Chesapeake. I-664 includes 20.8 miles of roadway and consists of four primary alignment sections: the Peninsula (Newport News), the MMMBT, south of the MMMBT (Suffolk), and Bowers Hill Area. The posted speed limit is 60 mph. The I-664 Study Area Corridor is shown in **Figure 2-4** through **Figure 2-7**.

**Figure 2-4: I-664 Study Area Corridor**



**Legend**

- Alternative Alignment on Existing Roadway
- Alternative Alignment on New Location
- Major Roads





Figure 2-5: I-664 Study Area Corridor, continued



**Figure 2-6: I-664 Study Area Corridor, continued**



**Legend**

-  Alternative Alignment on Existing Roadway
-  Alternative Alignment on New Location
-  Major Roads



**Figure 2-7: I-664 Study Area Corridor, continued**

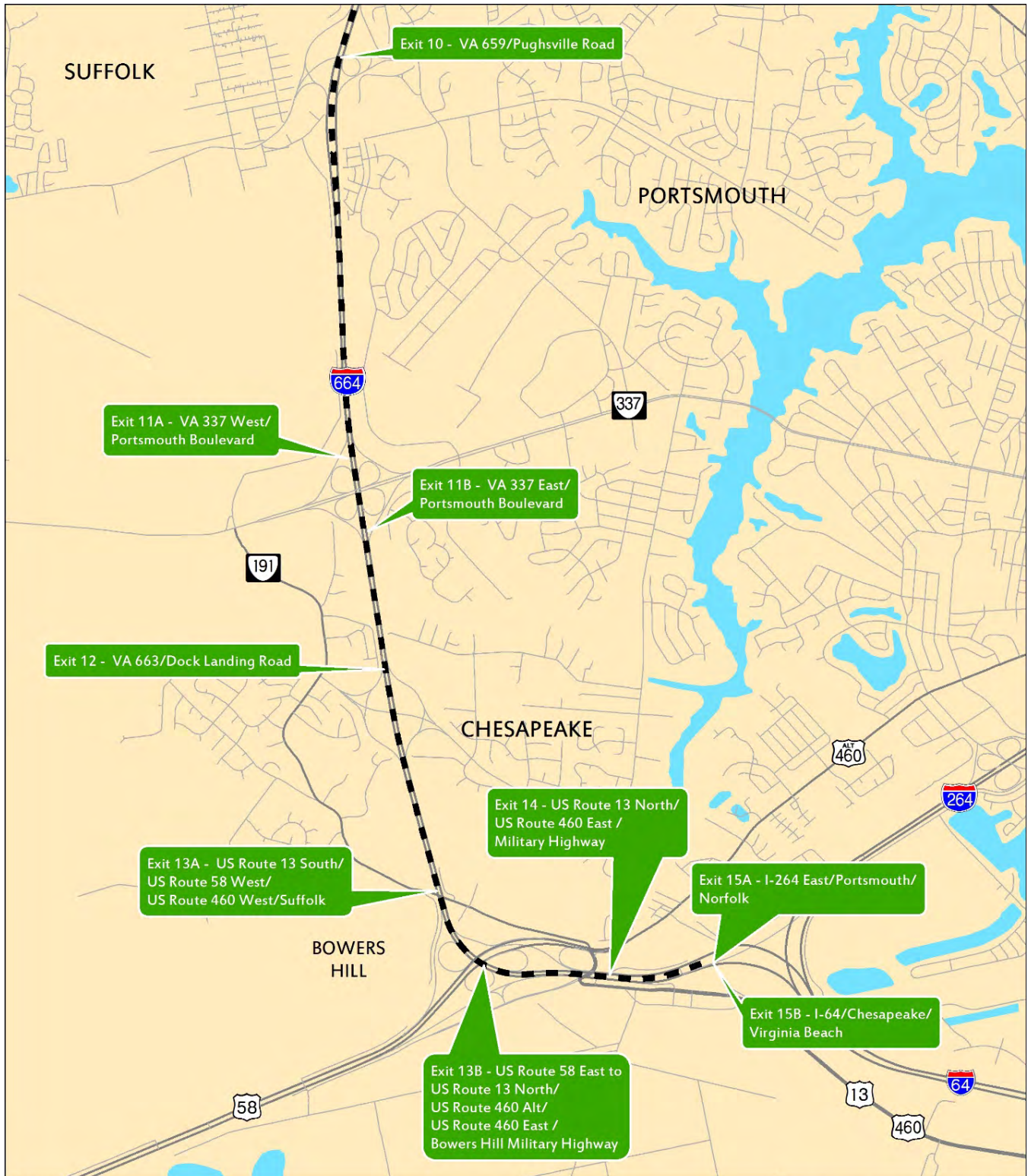

**Legend**

- Alternative Alignment on Existing Roadway
- Alternative Alignment on New Location
- Major Roads



**HRCS SEIS**  
Hampton Roads Crossing Study SEIS  
**I-664 Study Area Corridor**

### 2.2.1 Newport News

Within the Newport News section, I-664 is predominantly three lanes per direction, with acceleration, deceleration, and auxiliary lanes at the interchanges. The mainline typical section includes 12-foot travel lanes, 12-foot right shoulders, 10-foot left shoulders, and 10 to 12-foot right shoulders. The lane and shoulder widths meet current AASHTO interstate design standards; however, they do not meet current VDOT interstate design standards. The median is closed and northbound and southbound traffic are separated by a concrete barrier. The following interchanges are located in Hampton and Newport News:

- Exit 1A – Williamsburg/Richmond
- Exit 1B – Downtown Hampton/Norfolk/Virginia Beach
- Exit 2 – Power Plant Parkway/Powhatan Parkway
- Exit 3 – Aberdeen Road
- Exit 4 – Chestnut Avenue/Roanoke Avenue
- Exit 5 – 35th Street
- Exit 6 – 26<sup>th</sup> Street and 27<sup>th</sup> Street
- Exit 7 – Terminal Avenue

### 2.2.2 Monitor-Merrimac Memorial Bridge-Tunnel

The 5.5-mile MMMBT connects Newport News and Suffolk by spanning the Hampton Roads Harbor. It was opened to traffic in 1992. The structure is composed of 6,141-foot long northern approach bridges, a 0.8-mile-long tunnel, and 16,685-foot long southern approach bridges with 0.30-mile portal islands at the transitions between the bridges and the tunnels.

The bridges consist primarily of 72-foot long spans with a deck width of 44 feet. The bridge superstructure consists primarily of simple span AASHTO prestressed beams and cast-in-place concrete deck. The bridge piers were constructed with a concrete cap supported on prestressed concrete piles.

The approach bridges between the tunnels and the landside roadways have 12-foot wide lanes with 12-foot wide right shoulders and 4-foot wide left shoulders. The left shoulders do not meet current AASHTO design standards. The existing elevations of the bridges is 17.55 feet relative to North American Vertical Datum [NAVD] to bottom of girder, which does not meet the clearance specifications in the *Guide Specifications for Bridges Vulnerable to Coastal Storms* (AASHTO, 2009). Additionally, the bridges include a vertical curve to accommodate the passage of small vessels.

The four-lane, dual tunnel has 12-foot wide lanes and 1-foot shoulders. The vertical clearance is 16 feet 6 inches. The vertical clearance does not appear to be problematic along the MMMBT.

### 2.2.3 Suffolk

Within the Suffolk section, I-664 is predominantly two lanes per direction, with acceleration, deceleration, and auxiliary lanes at the interchanges. The mainline typical section includes 12-foot travel lanes, 12-foot right shoulders, and 3 to 10-foot left shoulders. The median is a varying width open section. Between Exit 9B and Exit 10, the median includes a Norfolk Southern railroad line. The lane and right shoulder widths meet current AASHTO and VDOT interstate design standards; however, the left shoulder width does not meet current AASHTO standards, which is ten to 12 feet. The following interchanges are located in Suffolk:

- Exit 8A – VA 135/North College Drive
- Exit 8B – VA 135 South/College Drive/Churchland
- Exit 9 – US Route 17 North/Bridge Road

- Exit 9A – US Route 17 North/Bridge Road/James River Bridge
- Exit 9B – VA 164 East/US Route 17 South/Portsmouth
- Exit 10 – VA 659/Pughsville Road
- Exit 11A – VA 337 West/Portsmouth Boulevard
- Exit 11B – VA 337 East/Portsmouth Boulevard
- Exit 12 – VA 663/Dock Landing Road

#### **2.2.4 Bowers Hill**

The Bowers Hill interchange area includes the southern terminus of I-664 and interchanges with I-264, US Route 13, US Route 58, and US Route 460.

I-664 is two lanes per direction, with acceleration, deceleration, and auxiliary lanes at the interchanges. The mainline typical section includes 12-foot travel lanes, 12-foot right shoulders, and 4-foot left shoulders. The lane and right shoulder widths meet current AASHTO and VDOT interstate design standards; however, the left shoulder width does not meet current AASHTO standards, which is ten to 12 feet. Additionally, weaving distances between the ramp gores are substandard.

The following interchanges are located in the Bowers Hill area:

- Exit 13A – US Route 13 South/US Route 58 West/US Route 460 West/Suffolk
- Exit 13B – US Route 58 East to US Route 13 North/US Route 460 Alt/US Route 460 East/Bowers Hill/Military Highway
- Exit 14 – US Route 13 North/US Route 460 East/Military Highway
- Exit 15A – I-264 East/Portsmouth/Norfolk
- Exit 15B – I-64/Chesapeake/Virginia Beach

### **2.3 INTERSTATE 564**

I-564 is the primary access route between Naval Station Norfolk (NAVSTA Norfolk), Naval Support Activity Hampton Roads (NSA Hampton Roads), and the Norfolk International Terminals (NIT) to the west and I-64 to the east. The road is approximately three miles long. The posted speed limit is 55 mph.

I-564 is three lanes per direction, with the left travel lane identified as an HOV lane. The mainline typical section includes 12-foot travel lanes, 12 to 14-foot right shoulders, and 4-foot left shoulders. The lane and right shoulder widths meet current AASHTO and VDOT interstate design standards; however, the left shoulder width does not meet current AASHTO standards. The median is closed and eastbound and westbound traffic are separated by a concrete barrier.

The following interchanges are located on I-564:

- VA 165/VA 170/Little Creek Road
- VA 406/Terminal Boulevard to Hampton Boulevard

Approximately 1.8 miles northwest of the I-564 and I-64 interchange, the new I-564 Intermodal Connector (IC) alignment, a separate project currently under construction, turns west and follows the Norfolk Southern rail line through NAVSTA Norfolk and NIT. The I-564 IC design includes a partial interchange at the NAVSTA Norfolk. The posted speed limit is expected to be 55 mph. The I-564 Study Area Corridor is shown in **Figures 2-8 through 2-10**.

Figure 2-8: I-564 Study Area Corridor



Legend

- Alternative Alignment on Existing Roadway
- Alternative Alignment on New Location
- Major Roads

0 0.15 0.3 0.6 Miles





**HRCS SEIS**  
Hampton Roads Crossing Study SEIS

**I-564 Study Area Corridor**

**Figure 2-9: I-564 Study Area Corridor, continued**



**Legend**

-  Alternative Alignment on Existing Roadway
-  Alternative Alignment on New Location
-  Major Roads

0 0.15 0.3 0.6 Miles



**HRCS SEIS**  
Hampton Roads Crossing Study SEIS

**I-564 Study Area Corridor**

Figure 2-10: I-564 Study Area Corridor, continued

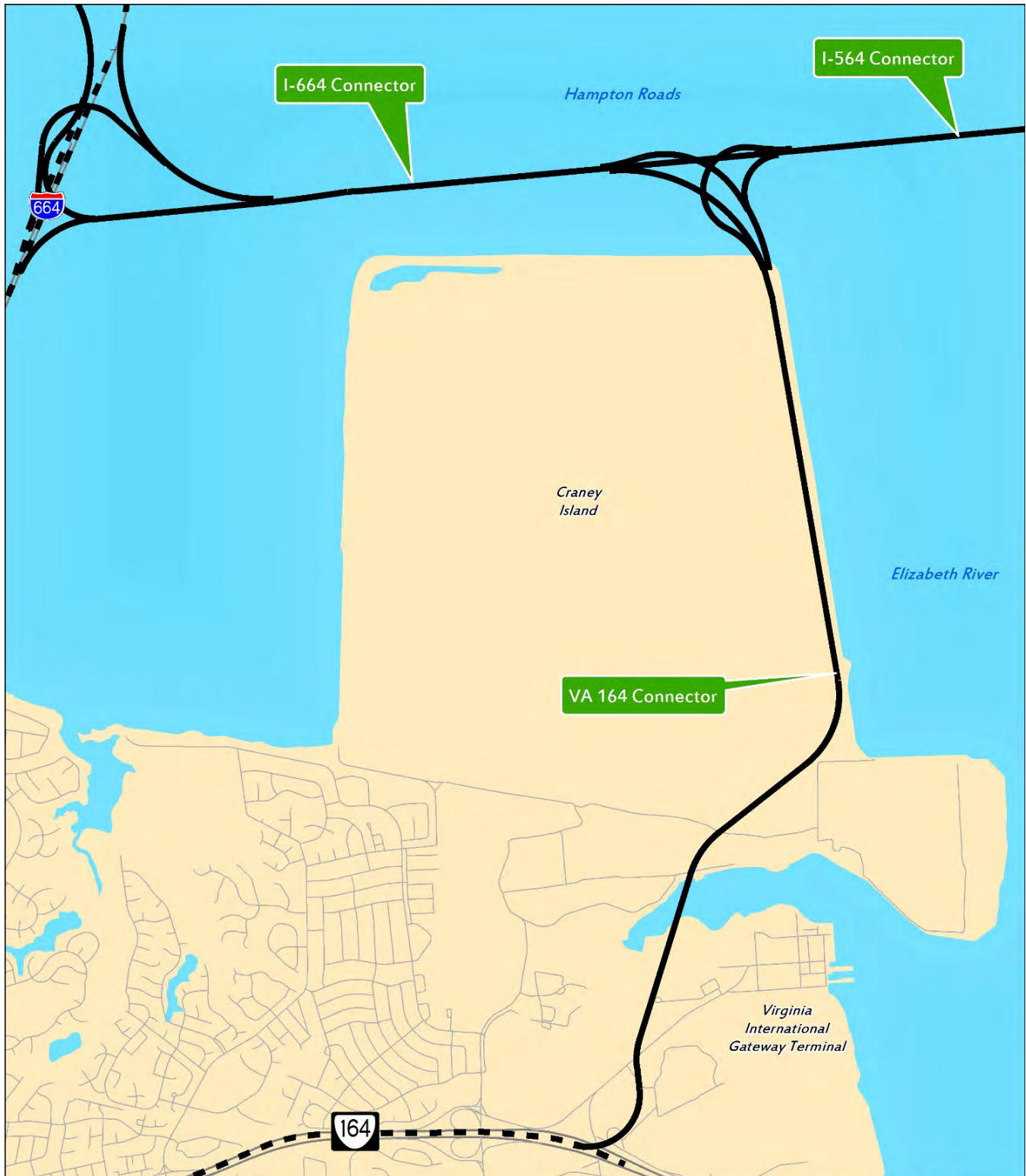

Legend

- - - Alternative Alignment on Existing Roadway
- Alternative Alignment on New Location
- Major Roads

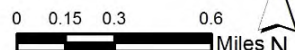



## 2.4 VIRGINIA ROUTE 164

Within the study limits, VA 164 runs west to east approximately 3.4 miles from the I-664 interchange to Virginia International Gateway (VIG) Boulevard, which provides access to a US Coast Guard facility. VA 164 is two lanes per direction and includes 12-foot travel lanes, 10-foot right shoulders, and 2-foot left shoulders with guardrail. The median is a varying width open section that includes two Commonwealth Railway railroad lines. The lane widths meet current AASHTO and VDOT interstate design standards; however, the right and left shoulder widths do not meet current AASHTO and VDOT standards. The posted speed limit is 60 mph.

Between College Drive and Towne Point Road, the centerlines of the Commonwealth Railway rail lines are located approximately 40 to 80 feet from the edge of existing travel lanes. Between Towne Point Road and Cedar Lane, the median widens and the centerline of the Commonwealth Railway rail lines are located approximately 40 to 46 feet from the edge of existing travel lanes. The VA 164 Study Area Corridor is shown in **Figure 2-11**.

The following interchanges are located along VA 164:

- VA 135/College Drive
- Towne Point Road
- Cedar Lane
- VIG Boulevard

**Figure 2-11: VA 164 Study Area Corridor**



**Legend**

- Alternative Alignment on Existing Roadway
- Alternative Alignment on New Location
- Major Roads

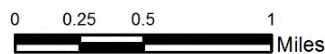

### 3. PREVIOUS STUDIES

The HRCS SEIS alternatives evaluation is informed by several previous studies including the 2001 HRCS FEIS and ROD; the 2012 HRBT Draft EIS; and the 2003, 2011, and 2013 re-evaluations of the 2001 FEIS. The SEIS is being prepared as a reevaluation of the 2001 FEIS and ROD, and as such the alternatives considered are based upon those evaluated in the original HRCS NEPA document.

#### 3.1 HRCS FEIS (2001)

The HRCS FEIS (*Hampton Roads Crossing Study Final Environmental Impact Study*, 2001) documented the Preferred Alternative for the HRCS. The FEIS evaluated three Candidate Build Alternatives (CBAs): 1, 2, and 9. CBA 9 was identified as the Preferred Alternative. More detail on the alternatives evaluated in the original HRCS FEIS is provided in **Section 4.2** of this report. Modified versions of CBAs 1, 2, and 9 have been reevaluated in this Draft SEIS as Alternatives A, B, and C, respectively. More detail on these alternatives is provided in **Section 7.2** of this report.

#### 3.2 2003 FEIS RE-EVALUATION

In November 2003, FHWA and VDOT completed a re-evaluation of the FEIS (*Hampton Roads Crossing Study Re-evaluation*, 2003) that analyzed implementing a portion of the Preferred Alternative, based on an unsolicited public-private partnership proposal. The data included in the re-evaluation documented that there did not appear to be any changes to the project or the surrounding environment that resulted in significant environmental impacts not already evaluated in the FEIS.

#### 3.3 2011 EA RE-EVALUATION

FHWA and VDOT prepared an Environmental Assessment (EA) re-evaluation of the HRCS FEIS (*Environmental Assessment Reevaluation of Hampton Roads Crossing Study FEIS: Candidate Build Alternative CBA 9 - Segments 1 & 3*, 2011) covering Segments 1 and 3 of CBA 9, locally referred to as “Patriots Crossing”, from the 2001 HRCS FEIS. Segment 1 would provide a new roadway and bridge from the southern end of the MMMBT to the planned I-564 Intermodal Connector in Norfolk while Segment 3 would provide a new facility extending south from Segment 1 along the east side of Craney Island Dredged Material Management Area (CIDMMA) to VA 164.

#### 3.4 HRBT (2012)

The HRBT Draft EIS (DEIS) (*Hampton Roads Bridge-Tunnel Draft Environmental Impact Statement*, 2012) evaluated a range of alternatives within the I-64 HRBT Study Area Corridor, with the same study limits as CBA 1 from the original HRCS FEIS and Alternative A in the current study. The Study Area included I-64 from the I-64 interchange with I-664 in the City of Hampton to the I-64 interchange with I-564 in the City of Norfolk, a distance of approximately 13.1 miles, including the 3.5-mile-long HRBT. Three Build Alternatives (Build-8, Build-8 Managed, and Build-10) were retained for detailed study.

During the public review of the HRBT DEIS, there was a clear lack of public or political support for the level of impacts associated with any of the Build Alternatives. Specifically, potential impacts to the historic district at Hampton University, Hampton National Cemetery, and the high number of displacements were key issues identified by the public, elected officials, and University and Veterans Affairs officials. Given this public opposition, a Preferred Alternative was not identified and the study did not advance. On August 20, 2015, FHWA rescinded its Notice of Intent to prepare the HRBT DEIS, citing public and agency comments and concerns over the magnitude of potential environmental impacts to a variety of resources,

such as impacts to historic resources as well as communities and neighborhoods. More detail on the alternatives evaluated in the original HRBT DEIS is provided in **Section 4.3** of this report.

### **3.5 2013 EA RE-EVALUATION**

The EA re-evaluation (*Revised Environmental Assessment Reevaluation of Hampton Roads Crossing Study FEIS: Candidate Build Alternative CBA 9 - Segments 1 & 3, 2013*) of the 2001 FEIS evaluated two sections from the Preferred Alternative identified in the 2001 FEIS and ROD: Segment 1 which would provide a new roadway and bridge-tunnel facility from the southern end of the MMMBT to the planned I-564 Intermodal Connector in Norfolk and Segment 3: a new facility extending south from Segment 1 along the east side of the CIDMMA to VA 164. Due to lack of funding for the project, FHWA was unable to approve the EA Re-evaluation. As the project continued to be considered for advancement, FHWA and VDOT agreed that it was appropriate to prepare an SEIS.

## **4. ALTERNATIVES PREVIOUSLY CONSIDERED**

The alternatives evaluated in the Major Investment Study (1997), HRCS FEIS (2001), the HRBT DEIS (2012), and those identified through the initial scoping phase of the SEIS are summarized below.

### **4.1 MAJOR INVESTMENT STUDY (1997)**

The Intermodal Surface Transportation Efficiency Act of 1991 (ISTEA) allocated demonstration funds for "... highway projects demonstrating innovative techniques of highway construction and finance." The I-64 crossing of Hampton Roads was included as one of the innovative projects. As was required at the time, a Major Investment Study (MIS) of the I-64 crossing was completed and published in 1997. The MIS documented an initial review of alternatives to reduce congestion at the I-64 crossing. The alternatives were screened as part of this process and those that were carried forward were evaluated in greater detail in the EIS that was published in 2001.

### **4.2 HRCS FEIS (2001)**

The 2001 study initially considered 45 alternatives included in the Major Investment Study (MIS) that ranged from congestion management strategies to the construction of a new crossing. The assessment of these initial alternatives included three levels of screening to identify the alternative corridor(s) that would meet the study's purpose and need. After the first two screenings were completed, 11 transportation corridors or alternatives remained. Of those 11 transportation corridors, three alternatives were carried forward as CBAs for detailed analysis: Transportation Corridor 1, Transportation Corridor 2 Modified, and Transportation Corridor 9.

#### **4.2.1 Alternatives Retained for Detailed Analysis**

##### **Transportation Corridor 1**

Transportation Corridor 1 was retained for detailed analysis in the FEIS as CBA 1. It would provide a new crossing parallel to the existing I-64 HRBT. CBA 1 would begin near the I-664 interchange in Hampton and would widen I-64 to eight general purpose travel lanes plus two multimodal lanes to the I-564 interchange in Norfolk.

### **Transportation Corridor 2 Modified**

Transportation Corridor 2 Modified was retained for detailed analysis as CBA 2. It would include all of CBA 1, widen I-564 in Norfolk to eight general purpose travel lanes plus two multimodal lanes, and construct a new four lane alignment that would begin at the I-564/I-64 interchange in Norfolk, extend across the Elizabeth River, travel along the east side of CIDMMA, and connect to VA 164 in Portsmouth.

### **Transportation Corridor 9**

Transportation Corridor 9 was retained for detailed analysis as CBA 9. It would widen I-664 to eight general purpose travel lanes plus two multimodal lanes on the Peninsula, widen to six general purpose lanes on the south side of the MMMBT, and provide a new parallel bridge tunnel adjacent to the MMMBT. CBA 9 would include a new roadway and bridge tunnel extending from I-664 to I-564 in Norfolk. This alternative would also widen I-564 to eight general purpose travel lanes plus two multimodal lanes and include a four-lane connection along the east side of CIDMMA connecting to VA 164 in Portsmouth. This alternative was identified as the Preferred Alternative in the 2001 FEIS and ROD, but this designation has been set aside for this SEIS.

#### **4.2.2 Alternatives Not Retained for Further Analysis**

### **Transportation Corridors 2 and 3**

Transportation Corridors 2 and 3 would provide a new crossing from Newport News to Norfolk, operating as a separate facility from I-664 MMMBT with a connection to VA 164. These Transportation Corridors were eliminated from further detailed study based on the ease of implementation and potential environmental impacts.

### **Transportation Corridor 4**

Transportation Corridor 4 would provide a new crossing parallel to the I-664 MMMBT and widen I-664 on the Southside and the Peninsula. This corridor was eliminated from further detailed study based on its inability to reduce traffic at the HRBT, address origin and destination patterns, or provide a direct connection to the major ports or naval facilities.

### **Transportation Corridors 5, 6, 7, 10, and 11**

Transportation Corridors 5, 6, 7, 10, and 11 would provide a new facility along the CSXT rail corridor from Newport News to I-64. These corridors were eliminated from further detailed study as a full typical section based on the criteria of ease of implementation and cost. The alternatives were not practicable because of the exorbitant cost for construction along the CSXT rail line, as well as the logistics, high impact and associated costs of relocating a large number of residences. Furthermore, these alternatives each encroached on areas containing potential habitat for federally listed threatened and endangered species.

### **Transportation Corridor 8**

Transportation Corridor 8 would provide a new crossing parallel to the MMMBT with a new connection to Norfolk and Portsmouth, including provision of a rail crossing of Hampton Roads, with no VA 164 connection. This alternative was eliminated from further detailed study because it did not provide new access to Portsmouth Marine Terminal or to the potential access between Naval Base Norfolk and the naval installations in Portsmouth, and it did not provide for a diversion point from I-64 during congestion causing incidents.

### 4.3 HRBT (2012)

A range of alternatives was initially considered in the 2012 HRBT DEIS, based on the Purpose and Need from that study, and a process that incorporated input from the public as well as local, state, and federal government agencies. The Purpose and Need for the HRBT DEIS identified a Level of Service (LOS) D as the screening threshold used for the study alternatives carried forward. An LOS threshold is not included in the HRCS. LOS is not considered the best indicator of improvements to the network, as it does not capture measurable improvements made within a given letter grade. In 2016, FHWA revised its guidance on LOS on the National Highway System to clarify that there is no LOS requirement on the highway system (FHWA, 2016).

See **Section 3.4** for more information on the public and agency lack of support for any of the Build Alternatives and FHWA's subsequent actions on the HRBT DEIS.

#### 4.3.1 Alternatives Retained for Detailed Analysis

The three retained Build Alternatives evaluated for the HRBT DEIS included the same termini for each alternative: improvements to I-64 would extend from just north of the I-664 interchange in Hampton, across the HRBT, and end at I-564 in Norfolk. These alternatives were not advanced beyond the HRBT DEIS.

##### Build-8

The Build-8 Alternative would provide four continuous mainline lanes in each direction of I-64 throughout the limits of the study. Through the Hampton section of the study, this alternative would require one lane of widening in each direction of I-64. Through the Norfolk section, this alternative would require the addition of two lanes in each direction of I-64.

##### Build-8 Managed

The Build-8 Managed Alternative is similar to the Build-8 Alternative, and would provide four continuous mainline lanes in each direction of I-64; however, some or all of the travel lanes would have been managed using tolls and/or vehicle occupancy restrictions (HOV, HOT, local bus service, and/or bus rapid transit).

##### Build-10

The Build-10 Alternative would provide five continuous mainline lanes in each direction of I-64 throughout the limits of the study. Throughout the Hampton section of the study, this alternative would involve widening both directions of I-64 by two lanes. In the Norfolk section of the study, this alternative would involve widening both directions of I-64 by three lanes.

#### 4.3.2 Alternatives Not Retained for Further Analysis

##### Transportation System Management (TSM) / Transportation Demand Management (TDM)

TSM/TDM improvements maximize the efficiency of the current transportation system or reduce the demand for travel on the system through the implementation of low-cost improvements. Examples of TSM activities include the addition of turn lanes, optimized signalization at intersections, and Intelligent Transportation Systems. Examples of TDM activities include ride sharing, van and carpooling, installation of park and ride facilities, and encouragement of telecommuting. TSM/TDM improvements, by their nature, are minor and therefore would not address inadequate capacity, congestion, or geometric deficiencies. Notwithstanding, the Retained Build Alternatives did not preclude TSM/TDM elements from

being implemented in conjunction with a Build Alternative. While not a standalone alternative, TSM/TDM improvements could be implemented independently or included as part of a Preferred Alternative.

#### **Rehabilitation or Reconstruction of the Existing HRBT**

This alternative would include rehabilitation of the superstructure or reconstruction of the substructure and superstructure of the HRBT approach bridges. Bridge rehabilitation would consist of the removal and replacement of the existing bridge superstructure, crack sealing, repair, jacketing existing piling, replacement of piling, and the replacement of parapets. The cost for rehabilitation was estimated to be \$256M for the HRBT approach bridges and \$48M for the MMMBT approach bridges. Reconstruction would consist of complete substructure (piers/foundations) and superstructure replacement, including raising and widening the structures to meet the current design standards. The cost for reconstruction was estimated to be \$360M for the HRBT approach bridges and \$855M for the MMMBT approach bridges. This alternative would not increase roadway capacity to alleviate current or future unacceptable and unreliable levels of traffic service, operating speeds, or travel times. While not a standalone alternative, rehabilitation or reconstruction was included as a component of the Retained Build Alternatives in the HRBT DEIS.

#### **Replacement of the Existing HRBT**

This alternative would include complete removal of the existing HRBT in conjunction with reconstruction of a new crossing facility in the same location. Geometrically deficient roadway infrastructure would be replaced by a new facility that would meet current design standards for shoulder widths, vertical clearance in tunnels, and vertical clearance above water for approach bridges. However, this alternative would not address the identified capacity needs as it only replaces the existing HRBT and would not provide additional capacity. This alternative would result in an unreasonably high level of disruption to regional travel during the construction period.

#### **Build-6 Alternative**

The Build-6 alternative presented in the 2012 HRBT DEIS would include construction of two additional lanes of capacity on I-64 at the Hampton Roads crossing and within the Norfolk section of the corridor, so that a continuous six-lane facility would extend from I-664 to I-564. The alternative would include a new two-lane bridge-tunnel at the Hampton Roads crossing. This alternative would partially address geometric deficiencies of existing facilities by constructing a new bridge-tunnel that would meet current design standards for shoulders, vertical clearance in tunnels, and vertical clearance over water. However, two additional lanes on the roadway would not provide adequate capacity to alleviate congestion for current or future traffic within the study corridor, and did not meet the LOS screening threshold established for the HRBT DEIS.

#### **Build-12 Alternative**

The Build-12 Alternative would construct six additional lanes of capacity on I-64 within the Hampton portion of the corridor, and eight additional lanes of capacity on I-64 on the Hampton Roads Bridge-Tunnel and within the Norfolk section of the corridor. This expansion would result in a continuous twelve-lane facility that would extend from I-664 to I-564. The alternative would improve capacity and address geometric deficiencies of existing facilities by constructing a new bridge-tunnel that would meet current design standards for shoulders, vertical clearance in tunnels, and vertical clearance above water. However, the Build-12 Alternative would likely result in proportionally greater impacts to right-of-way, wetlands, streams, historic properties, and community facilities compared to the other Retained

Alternatives. The alternative was not advanced because the Retained Build Alternatives in the 2012 HRBT DEIS adequately addressed the transportation needs with less environmental impact.

### **High Bridge Crossing**

The high bridge alternative would involve a new cable-stayed or suspension bridge parallel to the existing HRBT over the Hampton Roads channel. The bridge would be built to carry a sufficient number of lanes of I-64 over Hampton Roads to address the capacity need. This alternative would fully address the geometric deficiencies of the existing HRBT facilities by constructing a new bridge that would have full shoulders, no vertical clearance issues, and meet or exceed the minimum height above mean high water (MHW). However, a high bridge creates logistical challenges in terms of shipping and military vulnerability, and presents environmental impacts that a tunnel does not. Although a high bridge over Hampton Roads could be a feasible alternative from an engineering perspective and would address the stated transportation needs, the alternative created additional problems that made it unreasonable to retain.

### **Light or Heavy Rail Transit**

This alternative would include dedicated light or heavy rail transit on a new structure across Hampton Roads. The existing bridge-tunnels would remain. The Light or Heavy Rail Transit Alternative was not retained for further evaluation because it would not address the geometric deficiency needs identified by the 2012 HRBT DEIS study. The alternative would have limited ability to address capacity on the HRBT given the limited potential ridership. It also would require substantial new rail transit connections on the Peninsula and Southside, and it would have limited ability to accommodate existing and future traffic volumes on the HRBT.

### **Bus Transit**

This alternative would include expansion of existing bus transit services within the study corridor and across Hampton Roads. This service could be in the form of an increase in bus service, or a dedicated (express bus or bus rapid transit) facility. As a stand-alone alternative, increased bus service or a dedicated bus facility would not involve roadway or bridge-tunnel improvements; therefore, it would not address the identified geometric deficiencies. Expansion of the existing bus transit network alone would not attract enough riders to substantially address the capacity need within the I-64 HRBT corridor based on current and future bus ridership across the HRBT. Further, any increased bus service would also continue to rely on the existing HRBT facility, and its operation would be hampered by current capacity and deficiencies of existing facilities. Although a bus transit alternative was not a viable stand-alone alternative because it did not address capacity and geometric deficiency needs, it was considered as a component of the Retained Build Alternatives in the HRBT DEIS.

### **Ferry Service**

This alternative would provide a service to carry vehicles across Hampton Roads via water transport (hydrofoil or ferry). This alternative would not address the geometric deficiencies of the existing facilities, because no improvements would be made to the I-64 roadway or existing bridge-tunnel. It also would not address capacity needs because ridership would be expected to range between 600 and 1,100 vehicles daily, or approximately one percent of the existing traffic volume and less than one percent of the projected 2040 No-Build volume on the HRBT. Consequently, ferry service did not meet the Purpose and Need of the study.



**4.4 VERIFICATION FOR NOT RETAINING PREVIOUS ALTERNATIVES IN THIS SEIS**

Each of the alternatives previously considered and not retained for further analysis from prior studies (described in the previous sections) were reassessed at the initiation of this SEIS to determine if they would meet the updated purpose and need. VDOT provided FHWA and the federal Cooperating Agencies with a table, similar to the one below, which presented all of the alternatives considered in previous studies. This information was used in informing the federal concurrence on alternatives retained for analysis in this SEIS. **Table 4-1** summarizes the justification for eliminating alternatives that were not retained for analysis from previous studies.

**Table 4-1: Verification for Not Including in SEIS**

Alternative	Justification
<b>2001 HRCS FEIS</b>	
Transportation Corridors 2 and 3	Not retained for SEIS. The alternatives are not practicable because of the logistics of constructing a new facility that is separate from the MMMBT. The alternatives would not address existing geometric deficiencies.
Transportation Corridor 4	Not retained for SEIS. This alternative would not provide adequate capacity/congestion relief, transportation reliability, improved access to port facilities, or improved military connectivity. The alternative does not address existing geometric deficiencies.
Transportation Corridors 5, 6, 7, 10, and 11	Not retained for SEIS. The alternatives are not practicable because of the exorbitant cost for construction along the CSX line, as well as the logistics of displacing a large number of homes.
Transportation Corridor 8	Not retained for SEIS. The alternative would not provide adequate capacity/congestion relief, transportation reliability, and access to port and military facilities. This alternative was previously eliminated because it did not meet capacity needs. These needs have increased since this determination in 2001.
Alternative	Justification
<b>2012 HRBT DEIS</b>	
Transportation System Management / Transportation Demand Management	Not retained for SEIS due to inadequate capacity, congestion relief, and transportation reliability, as well as inability to address existing geometric deficiencies. This alternative would not improve access to port facilities, increase military connectivity, improve regional accessibility and capacity for evacuation, or improve intermodal access. While not a standalone alternative, TSM/TDM improvements could be implemented independently or included as part of a Preferred Alternative.
Rehabilitation or Reconstruction of the Existing HRBT	Not retained for SEIS due to inadequate capacity, congestion relief, and transportation reliability, as well as inability to address existing geometric deficiencies. This alternative would not improve access to port facilities, increase military connectivity, improve regional accessibility and capacity for evacuation, or improve intermodal access. While not a standalone alternative, rehabilitation or reconstruction of the existing HRBT could be included as a component of the alternatives retained for analysis.

Alternative	Justification
Replacement of the Existing HRBT	Not retained for SEIS due to inadequate capacity, congestion relief, and transportation reliability. This alternative would not improve access to port facilities, increase military connectivity, improve regional accessibility and capacity for evacuation, or improve intermodal access. Further, this alternative is not acceptable because of the impact to travel during construction.
Build-8 Alternative/Build 8-Managed	Not retained for SEIS. See <b>Section 3.4</b> for more information on the public and agency lack of support for any of the Build Alternatives and FHWA’s subsequent actions on the HRBT DEIS.
Build-10	Not retained for SEIS. See <b>Section 3.4</b> for more information on the public and agency lack of support for any of the Build Alternatives and FHWA’s subsequent actions on the HRBT DEIS.
Build-12 Alternative	Not retained for SEIS. See <b>Section 3.4</b> for more information on the public and agency lack of support for any of the Build Alternatives and FHWA’s subsequent actions on the HRBT DEIS.
High Bridge Crossing	Not retained for SEIS. A high bridge crossing of Hampton Roads would not address existing geometric deficiencies, and it could create vulnerability issues for the ports and the military.
Light or Heavy Rail Transit	Not retained for SEIS. The alternative would provide inadequate capacity/congestion relief and transportation reliability. It would not improve access to port facilities or increase military connectivity. Hampton Roads Transit provided VDOT with ridership projections and a recommendation that light rail or heavy rail transit not be considered further.
Bus Transit	Not retained for SEIS as a stand-alone alternative due to inadequate capacity/congestion relief and transportation reliability. It would not improve access to port facilities or increase military connectivity. It would not improve regional accessibility and capacity for evacuation. Hampton Roads Transit provided VDOT with ridership projections and a recommendation that high frequency bus rapid transit or enhanced bus service be included with the alternatives retained for analysis.
Ferry Service	Not retained for SEIS due to inadequate capacity/congestion relief and transportation reliability. It would not improve access to port facilities, increase military connectivity, or improve regional accessibility and capacity for evacuation. The alternative would not address geometric deficiencies.

#### 4.5 IMPROVEMENTS IDENTIFIED DURING SCOPING

Two additional options were identified during the scoping process for the Draft SEIS. They are described below.

##### 4.5.1 General Taylor Freeway

This alternative was recommended by the public during the initial scoping efforts to support the Draft SEIS. This option would move the over-water structures proposed in the 2001 FEIS north of the CIDMMA on to CIDMMA, to the greatest extent practicable. This alternative was not carried forward in the SEIS because no roadways can be built near any of the perimeter dikes on CIDMMA, per requirements by the US Army Corps of Engineers (USACE). Additionally, because CIDMMA is an active dredge disposal site, the island will increase in height in the coming years in that area.

**4.5.2 3-4-3**

This option was presented by the Hampton Roads Transportation Planning Organization (HRTPO) on November 19, 2015. The option would increase capacity on I-64 by adding lanes in existing right of way. It would include three lanes per direction approaching the tunnel in Hampton, four lanes per direction on the HRBT, and three lanes in both directions south of the HRBT.

This option is further reviewed in **Appendix D** of this Technical Report. While it has not been included with any of the alternatives, it could be applied to any alternative that includes improvements to the I-64 Study Area Corridor. This option would result in a 15 to 20 percent increase to the tunnel costs and a commensurate increase to the environmental impacts due to the additional tunnel and bridge width. If this option is incorporated into a Preferred Alternative, it would be analyzed in greater detail in the Final SEIS.

**5. ALTERNATIVES DEVELOPMENT AND EVALUATION PROCESS**

At the initiation of the HRCS SEIS, VDOT and FHWA developed a coordination plan for the study to ensure the document supports and meets the decision-making needs of the federal Cooperating Agencies, to the extent practicable. VDOT, FHWA, and federal agencies that have jurisdiction by law on FHWA/VDOT projects are developing an agreement to merge the NEPA/Section 404 process. More information on the Section 404 process can be found in Section 2.1 of the *HRCS Natural Resources Technical Report*. While this agreement is still being developed, FHWA and VDOT agreed to use the basic framework of that agreement for the HRCS. Namely, FHWA and VDOT have agreed to have three concurrence points for the federal Cooperating Agencies for:

Purpose and Need;

Alternatives to be Retained for Analysis; and

Recommended Preferred Alternative.

Other proposed components of the merged process under development such as timelines, roles and responsibilities of the federal agencies, other concurrence points, etc. are not included as part of the HRCS coordination plan.

Following the public comment period on the Draft SEIS, FHWA and VDOT will recommend to USACE the alternative the agencies believe should be identified as the Preferred Alternative and the preliminary LEDPA. This recommendation will be informed by the data presented in the Technical Reports and Draft SEIS. It will also be based on input received from the public during the Citizen Information Meetings (CIMs), Location Public Hearings, and associated comment periods and input from the Cooperating and Participating Agencies. This may provide sufficient information for USACE to determine the preliminary LEDPA. The LEDPA is not identified until a permit application is submitted. Identifying a preliminary LEDPA at this stage in project development provides support that the Preferred Alternative is permissible and can be implemented via individual projects/permits. With USACE concurrence on this recommendation, it will be presented to the Cooperating Agencies for concurrence as the recommended Preferred Alternative. This recommendation will then be presented to the Commonwealth Transportation Board (CTB) for official action. If approved by the CTB, the Preferred Alternative will be carried forward and documented in the Final SEIS.

The elements described below have been used as a basis for assessing the ability of the Retained Alternatives to meet the Purpose and Need of this SEIS.

## 5.1 ACCOMMODATE TRAVEL DEMAND

The population of the Hampton Roads region is expected to increase from 1.7 million in 2010 to 2.04 million by 2040 (HRTPO, 2013b). Average weekday daily traffic at the HRBT is expected to increase 26 percent. Similarly, average weekday daily traffic is expected to increase 41 percent at the MMMBT, 60 percent on I-564, and 29 percent on VA 164 in the Study Area Corridors.

Each retained alternative was assessed for its ability to provide improvements to important sections of the roadway network that would accommodate future travel demand.

## 5.2 IMPROVE TRANSIT ACCESS

In 2011, the Virginia Department of Rail and Public Transportation (DRPT), in cooperation with others, identified transit needs in Hampton Roads from a regional perspective, including the need for planning, building, and maintaining an integrated, high-speed/high-capacity transit system that would help relieve traffic congestion and connect activity centers throughout Hampton Roads. The plan calls for additional crossings over Hampton Roads, including dedicated transit facilities if improvements were made to the HRBT or another crossing. DRPT completed a study in November 2015 that recommended high frequency bus rapid transit (BRT) service either in a fixed guideway or in shared high occupancy vehicle (HOV) or high occupancy toll (HOT) lanes. (DRPT, 2015).

Each retained alternative was assessed for its ability to improve transit access across Hampton Roads either by improving transit capacity or access to transit.

## 5.3 INCREASE REGIONAL ACCESSIBILITY

Regional transportation accessibility focuses on getting people and goods to destinations in high demand. It is enhanced by increasing the speed of travel to reach a destination and the subsequent reduction in travel time. Moreover, for transportation to be accessible, it needs to be reliable so that people and goods arrive as planned. Each retained alternative was assessed for its ability to increase accessibility to regional activity centers. The alternatives evaluation focused on two key factors: increase capacity and relieve congestion.

### 5.3.1 Increase Capacity

Inadequate capacity leads to congestion which has an adverse effect on travel time and travel reliability. Traffic volumes on sections of I-64, I-664, I-564, and VA 164 routinely exceed capacity during peak periods. Due to constricted horizontal and vertical clearances, tunnels provide less capacity than landside roadways.

Each retained alternative was assessed for its ability to increase capacity to existing facilities or add new access to and from regional activity centers using roadways on new location.

### 5.3.2 Relieve Congestion

Because peak traffic exceeds existing capacity and there are only three crossings connecting the Peninsula to the Southside (HRBT, MMMBT, and the James River Bridge), non-recurring incidents during peak travel times can cause prolonged traffic jams that essentially bring the I-64 and I-664 corridors to a standstill, which in turn has a domino effect on traffic on intersecting roadways.

Each retained alternative was assessed for its ability to relieve congestion on key roadway sections including I-64, I-664, I-564, and VA 164.

## 5.4 ADDRESS GEOMETRIC DEFICIENCIES

Some elements along the mainline, interchanges, bridges, and tunnels along the I-64, I-664, I-564, and VA 164 Study Area Corridors do not meet the 2011 AASHTO and 2015 VDOT design standards based on the design speed. Geometric deficiencies identified in the Study Area Corridors include narrow median shoulders on the mainline and low vertical clearance within the existing tunnels under Hampton Roads. The screening criteria derived from the deficiencies need are primarily based on the design guidelines presented in **Tables 6-1, 6-2, and 6-3**.

Two key issues are representative of the geometric deficiencies of existing facilities in the Study Area Corridors: shoulder width and vertical clearance in tunnels.

### 5.4.1 Shoulder Width

Throughout the Study Area Corridors, left shoulders do not meet current 12-foot interstate design standards provided *A Policy on Geometric Design of Highways and Streets* (AASHTO, 2011) and the *Road Design Manual* (VDOT, 2015) for design speed. The MMMBT and HRBT bridge sections between the tunnels and the landside roadways have 10-foot wide right shoulders and 4-foot wide left shoulders that do not meet current design standards as provided by AASHTO and VDOT. The roadways through the tunnels do not have shoulders. This is inconsistent with current standards, which calls for two- to four-foot wide shoulders.

As described in the Purpose and Need, the lack of adequate shoulder width results in roadway congestion and management problems during incidents or minor construction/inspection because one or more of the travel lanes must be closed to through traffic. Providing adequate shoulder widths that meet design standards would allow emergency vehicles to use shoulders to access incidents; allow vehicles involved in an incident to pull out of the travel lane; and allow additional roadway width for maintenance of traffic during construction, maintenance, and inspection activities.

Each retained alternative was assessed for its ability to provide shoulder widths that meet current design standards.

### 5.4.2 Vertical Clearance in Tunnels

The existing vertical clearance for the HRBT is 13 feet 6 inches for the westbound tunnel and 14 feet 6 inches for the eastbound tunnel, and the vertical clearance for the MMMBT is 14 feet 6 inches. AASHTO minimum clearance is 16 feet, while VDOT requires 16 feet 6 inches for resurfacing activities. This limited vertical clearance is problematic for some trucks, particularly on the westbound HRBT. On the westbound HRBT over 1,600 trucks a year in 2015, or more than four trucks per day, were forced to turn around and use the higher clearance eastbound tunnel. Each truck turnaround process requires traffic to stop in both directions. The VDOT *Road Design Manual* establishes a vertical clearance of 16 feet 6 inches for interstates. Providing adequate vertical clearance in the westbound tunnel would allow all standard height trucks to cross the HRBT and eliminate the need to remove overheight vehicles from the traffic stream.

Accordingly, each retained alternative was assessed for its ability to provide vertical clearance in the tunnels that meet current design standards.

## 5.5 ENHANCE EMERGENCY EVACUATION CAPABILITY

Future road networks should include considerations for improving the capacity and options for evacuating citizens from the region (Virginia Department of Emergency Management (VDEM), 2014). If the

transportation network capacity does not accommodate the growth in population, the timely and efficient evacuation of the population will continue to be hampered.

Each retained alternative was assessed for its ability to enhance emergency evacuation capacity along existing evacuation routes or by adding new routes.

## **5.6 IMPROVE STRATEGIC MILITARY CONNECTIVITY**

I-64, I-564, I-664, and VA 164 provide connections for the movement of military personnel and equipment within the Study Area Corridors. These roadways are part of the Strategic Highway Network (STRAHNET), which is designated by FHWA in coordination with the US Department of Defense (DoD) (US Army, 2012). STRAHNET is the minimum network of highways that are important to the United States' strategic defense policy. With growing traffic volumes that exceed capacity, future military mobility and connectivity will increasingly decline in the Study Area Corridors which would result in a decrease in mobility for commuters who work at the more than 20 military installations located in the region. It will slow military travel between installations, and impact the efficient and timely movement of cargo and personnel during military operations, including at Ports for National Defense (PND) Program ports in the Hampton Roads region. Future needs include providing adequate capacity and reduced travel time and increased reliability for STRAHNET Study Area Corridors.

Each retained alternative was assessed for its ability to improve strategic military connectivity by providing adequate capacity, and increased reliability for the STRAHNET network by improving access to facilities.

## **5.7 INCREASE ACCESS TO PORT FACILITIES**

With freight volumes expected to grow in the future due to expansion of the Panama Canal, trucks will further contribute to and be impacted by roadway congestion. Each retained alternative was assessed for its ability to accommodate increased truck traffic from the Port of Virginia expansion while addressing congestion and the need to improve capacity to and from the port.

## **6. DESIGN CRITERIA**

Retained alternatives were developed based on the AASHTO *Policy on the Geometric Design of Highways and Streets* (AASHTO, 2011), the *Road Design Manual* (VDOT, 2015), *Road and Bridge Standards* (VDOT, 2008), *Structure and Bridge Manual* (VDOT, 2015), *Guide for High Occupancy Vehicle Facilities* (AASHTO, 2004), *A Policy on Design Standards Interstate System* (AASHTO, 2005), and the *Technical Manual for Design and Construction of Road Tunnels-Civil Elements* (FHWA-NHI-10-034, 2009). Structural design parameters guided the design of new structures crossing Hampton Roads and were based on recommendations by the Port of Virginia and the Virginia Maritime Association for vertical clearances and channel width for shipping as provided during scoping. Mainline and interchange geometric design guidelines used in the development of alternatives are presented in **Table 6-1** and **Table 6-2** and the structural design parameters are presented in **Table 6-3**.

**Table 6-1: Mainline Design Criteria**

Criteria	I-64 and I-564	I-664 and VA 164
VDOT Geometric Design Standard	Urban Principal Arterial System (GS-5) – Freeway-Level	Urban Principal Arterial System (GS-5) – Freeway-Level
Posted Speed Limit	55 mph	60 mph
Design Speed	Desired: 70 mph Minimum: 60 mph	Desired: 70 mph Minimum: 65 mph
Horizontal Alignment	Minimum Radius: 1,821' (70 mph) Minimum Radius: 1,204' (60 mph) All minimum radii will utilize VDOT TC 5.11R	Minimum Radius: 1,821' (70 mph) Minimum Radius: 1,488' (65 mph) All minimum radii will utilize VDOT TC 5.11R
Vertical Alignment	Minimum Grade: 0.5% Maximum Grade: 4%	Minimum Grade: 0.5% Maximum Grade: 4%
Stopping Sight Distance	Minimum: 730' (70 mph) Minimum: 570' (60 mph)	Minimum: 730' (70 mph) Minimum: 645' (65 mph)
Lane Width	12'	12'
Shoulder Width	<u>Mainline</u> Right: 17' (12' paved); 14' paved with concrete barrier Left (median): 12' paved <u>Tunnel</u> Right: 2' offset from barrier Left (median): 2' offset from barrier <u>Bridge (crossing)</u> Right: 14' Left (median): 6'; 14' with 6 or more lanes	<u>Mainline</u> Right: 17' (12' paved); 14' paved with concrete barrier Left (median): 12' paved <u>Tunnel</u> Right: 2' offset from barrier Left (median): 2' offset from barrier <u>Bridge (crossing)</u> Right: 14' Left (median): 6'; 14' with 6 or more lanes
Structure Width	Match clear roadway width	Match clear roadway width
Cross Slope / Superelevation	Normal: 2% Maximum: 8% TC 5.11R	Normal: 2% Maximum: 8% TC 5.11R
Vertical Clearance	16'-6"	16'-6"
Clear Zone Width	30'-34'	30'-34'
Roadside Barrier	National Cooperative Highway Research Program (NCHRP) 350 or MASH approved Guardrail, Concrete Barrier, End Treatment, and Impact Attenuating Devices	National Cooperative Highway Research Program (NCHRP) 350 or MASH approved Guardrail, Concrete Barrier, End Treatment, and Impact Attenuating Devices
Median Barrier	NCHRP approved Concrete Barrier, End Treatment, and Impact Attenuating Devices	NCHRP approved Concrete Barrier, End Treatment, and Impact Attenuating Devices
Side Slopes	Desired: 6 Horizontal (H):1 Vertical (V) or flatter Minimum: 4H:1V w/o barrier 2H:1V w/barrier CS-4 Slope Standard	Desired: 6 Horizontal (H):1 Vertical (V) or flatter Minimum: 4H:1V w/o barrier 2H:1V w/barrier CS-4 Slope Standard

**Table 6-2: Interchange Design Criteria**

Criteria	Direct Connection Ramps	Loop and Diamond Ramps
VDOT Geometric Design Standard	Interchange Ramps (GS-R) -Level	Interchange Ramps (GS-R) -Level
Posted Speed Limit	Varies	Varies
Design Speed	Desired: 50 mph Minimum: 45 mph	Minimum: 30 mph
Horizontal Alignment	Minimum Radius: 760' (50 mph) Minimum Radius: 589' (45 mph)	Minimum Radius: 215'
Vertical Alignment	Minimum Grade: 0.5% Maximum Upgrade: 5% Maximum Downgrade: 4%	Minimum Grade: 0.5% Maximum Upgrade: 5% Maximum Downgrade: 4%
Stopping Sight Distance	Minimum: 425' (50 mph) Minimum: 360' (45 mph)	Minimum: 200'
Lane Width	Single lane: 16' Two lanes: 12' per lane	Single lane: 16' Two lanes: 12' per lane
Shoulder Width	Right: 11' (8' paved) Left: 9' (4' paved)	Right: 11' (8' paved) Left: 9' (4' paved)
Structure Width	Match clear roadway width	Match clear roadway width
Cross Slope / Superelevation	Normal: 2% Maximum: 8%	Normal: 2% Maximum: 8%
Vertical Clearance	16'-6"	16'-6"
Clear Zone Width	Desired: 30' – 34' or 14' from edge of traveled way to protective barrier Minimum: typical section shoulder width from edge of pavement to face of protective barrier	Desired: 30' – 34' or 14' from edge of traveled way to protective barrier Minimum: typical section shoulder width from edge of pavement to face of protective barrier
Roadside Barrier	NCHRP 350 or MASH approved Guardrail, Concrete Barrier, End Treatment, and Impact Attenuating Devices	NCHRP 350 or MASH approved Guardrail, Concrete Barrier, End Treatment, and Impact Attenuating Devices
Median Barrier	N/A	N/A
Side Slopes	Desired: 6H:1V or flatter Minimum: 4H:1V w/o barrier 2H:1V w/barrier CS-4	Desired: 6H:1V or flatter Minimum: 4H:1V w/o barrier 2H:1V w/barrier CS-4



**Table 6-3: Structural Design Parameters**

Design Parameter		All Bridge Crossing	Tunnel Crossing
Clearance Under Channel		N/A	Desired: 65' to top of tunnel armor from mean low water (MLW) Minimum: 60' to top of tunnel armor from MLW <sup>2</sup>
Vertical Clearance Above Water for Approach Bridges		Elevation of Bottom of Superstructure: 18' relative to NAVD 88 <sup>1</sup>	Elevation of Bottom of Superstructure: 18' relative to NAVD 88 <sup>1</sup>
Width of Channel	HRBT	N/A	Minimum: 1,000' (per Port of Virginia)
	MMMBT	N/A	Minimum: 750' (per Port of Virginia)
	Elizabeth River	N/A	Minimum: 1,250' (per Port of Virginia)
Horizontal Offset from Existing Tunnel/Bridge		200' minimum (outside of structure to outside of structure)	200' minimum (outside of structure to outside of structure)
Horizontal Offset between New Tunnels		50' minimum (outside of structure to outside of structure)	50' minimum (outside of structure to outside of structure)

<sup>1</sup> Elevation 18 feet includes 1 foot of clearance above the 100-year design wave crest elevation (elevation 12 feet relative to North American Vertical Datum [NAVD] plus 1 foot) per Guide Specifications for Bridges Vulnerable to Coastal Storms (AASHTO, 2009), plus an assumed 5 feet for potential sea level rise over the next century per VDOT Structure and Bridge Division standard practice.

<sup>2</sup> Clearance under channel from existing top of tunnel to MLW is ±55 feet.

## 7. ALTERNATIVES

Five alternatives are under consideration for the Draft SEIS and are assessed in detail in this Technical Report.

### 7.1 NO-BUILD ALTERNATIVE

Under the No-Build Alternative, the Study Area Corridors would remain as they are today as described in **Section 2**.

Under the No-Build Alternative, VDOT would continue maintenance and repairs of the existing roadways, bridges, and tunnels, as needed, with no substantial changes to current capacity or management activities. Specifically, there would be no rehabilitation or reconstruction of the HRBT or MMMBT.

### 7.2 BUILD ALTERNATIVES

Four Build Alternatives are under consideration for the Draft SEIS: Alternatives A, B, C, and D. The Build Alternatives are based on alternatives studied in earlier documents including the 2001 HRCS FEIS, which is described in more detail in **Section 3**.

Only Alternative C includes dedicated transit facilities in specific locations. Dedicated transit facilities are limited to this alternative in these locations because that is where transit was included in CBA 9 in the 2001 HRCS FEIS. As part of the Preferred Alternative, transit could be included elsewhere, if applicable. The means by which transit is included in the Preferred Alternative would be documented in the Final SEIS. For the purposes of this Draft SEIS, transit assumes BRT. In the Final SEIS, transit could be redefined or used as a managed lane.

Each of the four Build Alternatives are comprised of alignment segments. Some of the alignment segments are included in multiple Build Alternatives. The geographic alignment segments are described in detail in **Section 8** so that information is not repeated in each alternative description.

**7.2.1 Alternative A**

Alternative A is based on CBA 1 from the 2001 HRCS FEIS.

Alternative A begins at the I-64/I-664 interchange in Hampton and creates a consistent six-lane facility by widening I-64 to the I-564 interchange in Norfolk. A parallel bridge-tunnel would be constructed west of the existing I-64 HRBT. See **Section 3.4** for more information on the public and agency lack of support for any of the Build Alternatives and FHWA’s subsequent actions on the HRBT DEIS. Consequently, VDOT and FHWA have committed that improvements proposed in the HRCS SEIS to the I-64 corridor would be largely confined to existing right-of-way. To meet this commitment, Alternative A consists of a six-lane facility. This is discussed in more detail in **Section 4.3**. Lane configurations are shown in **Figure 7-1** and summarized in **Table 7-1**. Alternative A plan sheets are included in **Appendix A**.

**Table 7-1: Alternative A Lane Configurations**

Roadway Alignments	Existing Lanes	Proposed Lanes
I-64 (Hampton)	4-6	6
I-64 (HRBT and Norfolk)	4	6

Alternative A is comprised of the following Alignment Segments described in more detail in **Section 8** and summarized in **Table 7-2**. See **Figure 8-1** for more information on the alignment segments.

**Table 7-2: Alternative A Alignment Segments**

Segment Number	Alignment Segments
8	I-64 from I-664 to Mallory Street interchange
9	I-64 from Mallory Street interchange to I-564

**Figure 7-1: Alternative A Lane Configurations**



**7.2.2 Alternative B**

Alternative B is based on CBA 2 from the 2001 HRCS FEIS.

Alternative B would include all of the improvements included under Alternative A, as well as the existing I-564 corridor that extends from its intersection with I-64 west toward the Elizabeth River. I-564 would be extended to connect to a new bridge-tunnel across the Elizabeth River (i.e., I-564 Connector). A new roadway (the VA 164 Connector) would extend south from the I-564 Connector, along the east side of CIDMMA, and connect to existing VA 164 just west of the VIG Boulevard Interchange. VA 164 would be widened from this interchange west to I-664. Alternative B lane configurations are shown in **Figure 7-2** and summarized in **Table 7-3**. Alternative B plan sheets are included in **Appendix A**.

The inclusion of the VA 164 Study Area Corridor is new to the HRCS. During the initial public scoping efforts conducted as part of the SEIS, the public suggested that improvements to VA 164 could supplement or replace more expensive over-water movements that had previously been analyzed in the 2001 HRCS FEIS. Improvements to VA 164 were incorporated into Alternative B to provide a basis to evaluate this public suggestion.

**Table 7-3: Alternative B Lane Configurations**

Roadway Alignments	Existing Lanes	Proposed Lanes
I-64 (Hampton)	4-6	6
I-64 (HRBT and Norfolk)	4	6
I-564	6	6
I-564 Connector	none	4
VA 164 Connector	none	4
VA 164	4	6

*Note: The I-564 IC is a separate project from HRCS and lies between the I-564 Connector and I-564. It is under construction and would be completed regardless of whether the HRCS improvements are made and therefore is included under the No-Build Alternative and is not listed with other proposed improvements.*

Alternative B is comprised of the following Alignment Segments described in more detail in **Section 8** and summarized in **Table 7-4**. See **Figure 8-1** for more information on the alignment segments.

**Table 7-4: Alternative B Alignment Segments**

Segment Number	Alignment Segments
8	I-64 from I-664 to Mallory Street interchange
9	I-64 from Mallory Street interchange to I-564
10B/D	I-564 and I-564 Connector, Alternatives B and D
12B	I-564 Connector and VA 164 Connector Interchange, Alternative B
13	VA 164 Connector
14	VA 164

Figure 7-2: Alternative B Lane Configurations



**HRCS SEIS**  
Hampton Roads Crossing Study SEIS  
Alternative B  
Segments

**7.2.3 Alternative C**

Alternative C is based on CBA 9 from the 2001 HRCS FEIS.

Alternative C would include widening along I-664 beginning at the I-664/I-64 interchange in Hampton and continuing south to the I-264 interchange in Chesapeake. It would include the same improvements along I-564, the I-564 Connector, and the VA 164 Connector that were considered in Alternative B. This alternative would not include improvements to I-64 or to VA 164 beyond the connector. Instead, this alternative would include the conversion of two existing lanes on I-564 in Norfolk to transit-only lanes. The decision to include transit-only lanes was based on input from DRPT and is discussed in **Section 5.2**. The inclusion of HOT or HOV in these transit-only lanes has not been considered but would be documented in the Final SEIS if it is identified as part of the Preferred Alternative.

This transit conversion would continue from I-564 along the I-564 Connector to its intersection with the VA 164 Connector. At that point, a new bridge structure (I-664 Connector) would continue west and tie into I-664. The transit-only lanes would extend across the I-564 Connector and I-664 Connector and continue north along I-664 to its terminus at I-64. Vehicles using the transit-only lanes wishing to continue south of Hampton Roads on I-664 would need to merge into the general purpose lanes prior to the MMMBT.

The dedicated transit facilities are limited to these locations in keeping with CBA 9 in the 2001 HRCS FEIS. As part of the Preferred Alternative, transit could be included elsewhere, if applicable. The means by which transit is included in the Preferred Alternative would be documented in the Final SEIS. For the purposes of this Draft SEIS, transit assumes BRT.

Alternative C lane configurations are shown in **Figure 7-3** and summarized in **Table 7-5**. Alternative C plan sheets are included in **Appendix A**.

**Table 7-5: Alternative C Lane Configurations**

Roadway Alignments	Existing Lanes	Proposed Lanes
I-664 (from I-64 to the proposed I-664 Connector)	4-6	8 + 2 Transit Only
I-664 (from the proposed I-664 Connector to VA 164)	4	8
I-664 (from VA 164 to I-264)	4	6
I-564	6	4 + 2 Transit Only
I-564 Connector	none	4 + 2 Transit Only
VA 164 Connector	none	4
I-664 Connector	none	4 + 2 Transit Only

*Note: The I-564 IC is a separate project from HRCS and lies between the I-564 Connector and I-564. It is under construction and would be completed regardless of whether the HRCS improvements are made and therefore is included under the No-Build Alternative and is not listed with other proposed improvements.*

Alternative C is comprised of the following Alignment Segments described in more detail in **Section 8** and summarized in **Table 7-6**. See **Figure 8-1** for more information on the alignment segments.

**Table 7-6: Alternative C Alignment Segments**

<b>Segment Number</b>	<b>Alignment Segments</b>
1	I-664 from US 58 (Bowers Hill) to I-264
2	I-664 from VA 164 to US 58 (Bowers Hill)
3	I-664 and VA 164 Interchange
4	I-664 from I-664 Connector to VA 164
5C	I-664 from Terminal Avenue Interchange to I-664 Connector, Alternative C
6C	Terminal Avenue Interchange, Alternative C
7C	I-664 from I-64 to Terminal Avenue Interchange, Alternative C
11C	I-664 Connector including I-664 Interchange, Alternative C
10C	I-564 and I-564 Connector, Alternative C
12C	I-564 Connector, I-664 Connector, and VA 164 Connector Interchange, Alternative C
13	VA 164 Connector

Figure 7-3: Alternative C Lane Configurations





**7.2.4 Alternative D**

Alternative D is a combination of the sections that comprise Alternatives B and C, although Alternative D does not contain dedicated transit-only lanes. Alternative D lane configurations are shown in **Figure 7-4** and summarized in **Table 7-7**. Alternative D plan sheets are included in **Appendix A**.

Alternative D was not included in the 2001 FEIS or any of the subsequent re-evaluations. This new alternative was identified during the initial scoping efforts for the SEIS. Compared to Alternative C, this alternative does not include dedicated transit lanes in order to provide a comparison of costs and impacts along the I-664, I-664 Connector, and I-564 Connector Study Area Corridors to inform the identification of a Preferred Alternative. This alternative was included in response to initial comments and financial estimates prepared by the Hampton Roads Transportation Accountability Commission that suggested the organization could fund improvements to all of the Study Area Corridors over time.

**Table 7-7: Alternative D Lane Configurations**

Roadway Alignments	Existing Lanes	Proposed Lanes
I-64 (Hampton)	4-6	6
I-64 (HRBT and Norfolk)	4	6
I-664 (from I-64 to VA 164)	4-6	8
I-664 (from VA 164 to I-264)	4	6
I-664 Connector	None	4
I-564	6	6
I-564 Connector	none	4
VA 164 Connector	none	4
VA 164	4	6

*Note: The I-564 IC is a separate project from HRCS and lies between the I-564 Connector and I-564. It is under construction and would be completed regardless of whether the HRCS improvements are made and therefore is included under the No-Build Alternative and is not listed with other proposed improvements.*

Alternative D is comprised of the following Alignment Segments described in more detail in **Section 8** and summarized in **Table 7-8**. See **Figure 8-1** for more information on the alignment segments.

**Table 7-8: Alternative D Alignment Segments**

Segment Number	Alignment Segments
8	I-64 from I-664 to Mallory Street interchange
9	I-64 from Mallory Street interchange to I-564
1	I-664 from US 58 (Bowers Hill) to I-264
2	I-664 from VA 164 to US 58 (Bowers Hill)
3	I-664 and VA 164 Interchange
4	I-664 from I-664 Connector to VA 164
5D	I-664 from Terminal Avenue Interchange to I-664 Connector, Alternative D
6D	Terminal Avenue Interchange, Alternative D
7D	I-664 from I-64 to Terminal Avenue Interchange, Alternative D
10B/D	I-564 and I-564 Connector, Alternatives B and D
11D	I-664 Connector including I-664 Interchange, Alternative D
12D	I-564 Connector, I-664 Connector, and VA 164 Connector Interchange, Alternative D
13	VA 164 Connector
14	VA 164



## 8. ALIGNMENT SEGMENTS

The four Build Alternatives described in **Section 7** are comprised of alignment segments. Some of the alignment segments are included in multiple Build Alternatives. The alignment segments are described below in **Table 8-1** and shown on **Figure 8-1**.

**Table 8-1: Alignment Segments**

Segment Number	Alignment Segment Description
1	I-664 from US 58 (Bowers Hill) to I-264
2	I-664 from VA 164 to US 58 (Bowers Hill)
3	I-664 and VA 164 Interchange
4	I-664 from I-664 Connector to VA 164
5C	I-664 from Terminal Avenue Interchange to I-664 Connector, Alternative C
5D	I-664 from Terminal Avenue Interchange to I-664 Connector, Alternative D
6C	Terminal Avenue Interchange, Alternative C
6D	Terminal Avenue Interchange, Alternative D
7C	I-664 from I-64 to Terminal Avenue Interchange, Alternative C
7D	I-664 from I-64 to Terminal Avenue Interchange, Alternative D
8	I-64 north of HRBT
9	I-64 from HRBT to I-564
10B/D	I-564 and I-564 Connector, Alternatives B and D
10C	I-564 and I-564 Connector, Alternative C
11C	I-664 Connector including I-664 Interchange, Alternative C
11D	I-664 Connector including I-664 Interchange, Alternative D
12B	I-564 Connector and VA 164 Connector Interchange, Alternative B
12C	I-564 Connector, I-664 Connector, and VA 164 Connector Interchange, Alternative C
12D	I-564 Connector, I-664 Connector, and VA 164 Connector Interchange, Alternative D
13	VA 164 Connector
14	VA 164

Figure 8-1: Alignment Segments



## **8.1 INTERSTATE 64**

Alternatives A, B, and D in the I-64 Study Area Corridor would provide six continuous mainline lanes of I-64 from I-664 to I-564. No-Build typical sections are shown in **Figure 8-2**, proposed typical sections are shown in **Figure 8-3**, and plan sheets are provided in **Appendix A**. I-64 is broken down into two alignment segments which are described below.

### **8.1.1 Segment 8: Interstate 64 north of HRBT**

From I-664 to the Settlers Landing Road interchange in Hampton, minor widening would occur to provide six continuous travel lanes, three in each direction. Between the Settlers Landing Road interchange and the Mallory Street interchange, eastbound I-64 narrows to two travel lanes, while three travel lanes are maintained westbound. One additional through lane would be constructed along eastbound I-64 between the two interchanges to maintain lane continuity. See **Figure 8-3** for more detail.

The typical section at the widening would include a 12-foot travel lane, 12-foot inside shoulders, and 12-foot to 14-foot outside shoulders. The total pavement width of the proposed improvements would be approximately 16 to 26 feet of outside pavement widening on the eastbound side of the highway. Because of the proximity of Hampton University, guardrail and 2:1 side slopes would be utilized to minimize property impacts.

From Mallory Street to the HRBT, roadway improvements would include one lane of widening in each direction plus geometric modifications needed to tie into the new eastbound bridge and tunnel. The typical section would include 12-foot travel lanes and 14-foot shoulders and the eastbound and westbound directions would be separated by a concrete traffic barrier. The inside shoulder would be widened from 8 feet to 12 feet to meet the geometric design criteria. The total pavement width of the proposed improvements would be approximately 16 to 26 feet of outside pavement widening on both sides of the roadway between Mallory Street and the HRBT.

**Figure 8-2: I-64 No-Build Typical Sections**

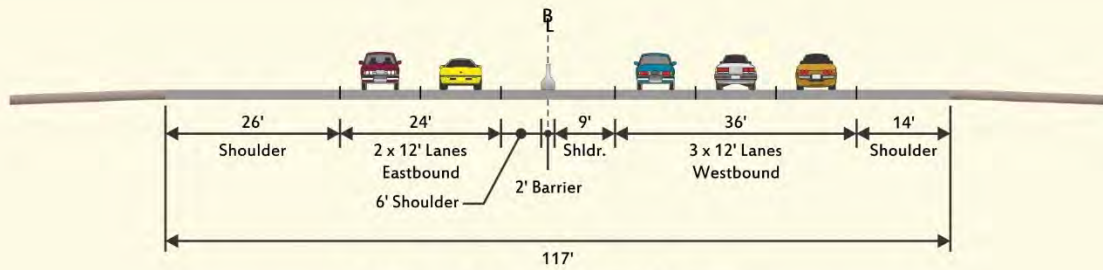

**Existing 5-Lane Typical Section  
from Mallory Street to Settlers Landing Road**

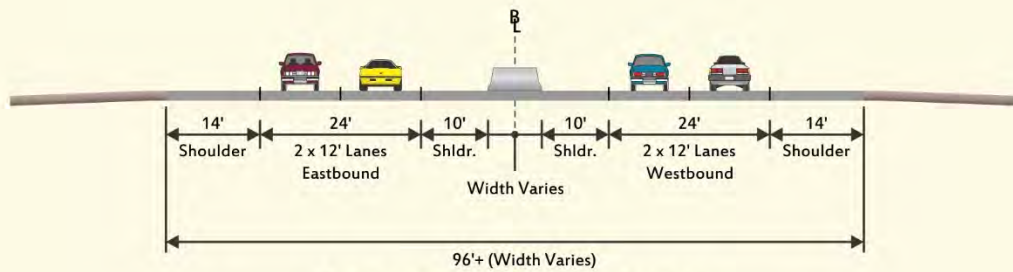

**Existing 4-Lane Typical Section  
from I-564 Interchange to West Ocean Avenue - Willoughby Spit**

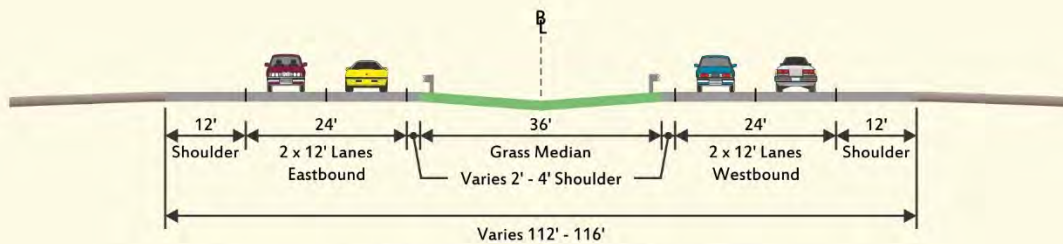

**Existing 4-Lane Typical Section  
from I-564 Interchange to West Ocean Avenue - Willoughby Spit**

Note: I-64 is on structure between West Ocean View Avenue / Bayville Street and 4th View Street with 4' left shoulder and 12' right shoulder

Not to scale

**LEGEND**

Existing Roadway



**HRCS SEIS**  
Hampton Roads Crossing Study SEIS  
**I-64 No-Build  
Typical Sections**

**Figure 8-3: I-64 Proposed Typical Sections**

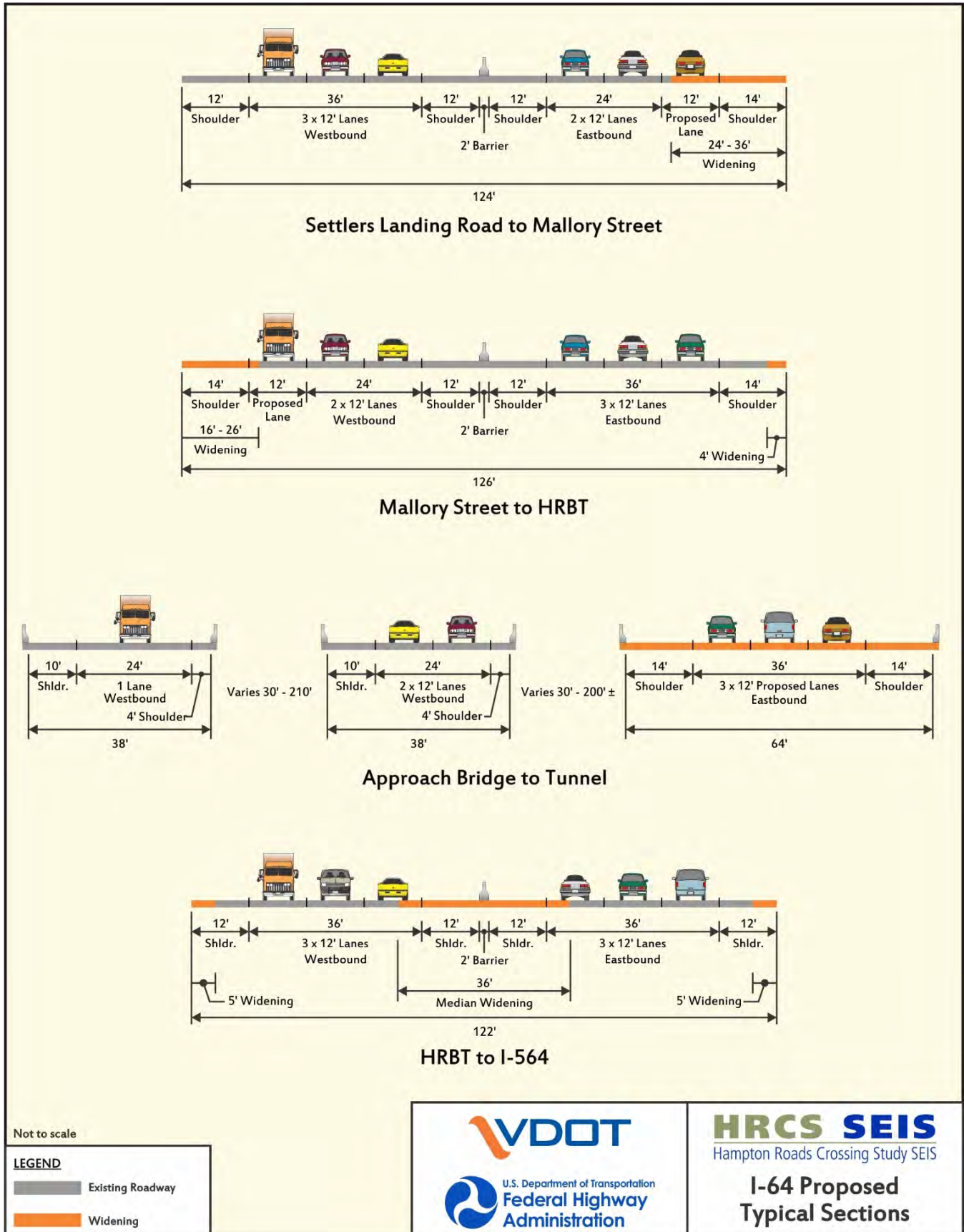

### 8.1.2 Segment 9: Interstate 64 from North Shoreline to I-564

Through this segment of the I-64 Study Area Corridor, Alternatives A, B, and D would require one lane of widening in each direction. See **Figure 8-3** for more detail.

This segment would include a new tunnel and approach bridges adjacent to the existing HRBT, which are described in detail in **Section 10.5** and **Section 10.6**.

South of the crossing, the typical section would include 12-foot travel lanes, 14-foot shoulders, and a concrete barrier between the eastbound and westbound lanes. The inside shoulder would be widened from 8 feet to 12 feet to meet the geometric design criteria described in **Section 6**. The pavement width of the proposed improvements would include up to 10 feet of outside pavement widening on both sides of the highway and widening into the existing 38-foot grass median.

Interchange improvements at Exit 273 – US 60/4<sup>th</sup> View Street; Exit 274 – West Bay Avenue; the westbound entrance ramp from Granby Street to I-64 just north of Norfolk Naval Station Gate 22 and the Forest Lawn Cemetery; and the eastbound entrance ramp from Norfolk Naval Station Gate 22 to I-64 would include adjustments to the ramp gore areas to accommodate the widened mainline. No major interchange reconfigurations are proposed.

At the eastern study limit (east of the I-564 interchange) in the eastbound direction, the third travel lane would exit onto I-564 as a lane drop. In the westbound direction, the third travel lane would be added by converting the existing I-564 on-ramp to an additional lane rather than a merge lane.

Sound walls exist in many locations along this segment and are located a minimum of 16 feet beyond the edge of the existing travel lane. The existing sound walls are proposed to remain in place in this segment unless noise analysis determines that they offer inadequate mitigation, requiring the consideration of larger barriers.

#### Willoughby Bay Bridges

Willoughby Spit is a peninsula located on the south side of Hampton Roads. Approximately 3,000 feet of I-64 is located at-grade between the HRBT bridges and the 4,990-foot long Willoughby Spit bridges. The existing eastbound bridge has two 12-foot travel lanes, a six-foot left shoulder and a 12-foot right shoulder for a total deck width of 44 feet. The westbound bridge has two 12-foot travel lanes, an eight-foot left shoulder and a 12-foot right shoulder for a total deck width of 46 feet. The eastbound bridge has an FHWA sufficiency rating of 81.5 and the westbound bridge has an FHWA sufficiency rating of 80.9. Structures with an FHWA sufficiency rating less than 75 but not yet rated structurally deficient would include rehabilitation to the existing bridge. Since both ratings are greater than 75, they will not require any repair work. More information on the criteria developed to determine whether an existing bridge would need to be replaced, repaired, or widened can be found in **Section 10.5**.

Improvements to the I-64 Study Area Corridor for Alternatives A, B, and D would include widening to three lanes along both eastbound and westbound bridges. Both bridges would maintain their northern edges and widen to the south approximately 20 feet to include the third 12-foot lane and additional shoulder width. The newly expanded bridges would have three 12-foot lanes, 12-foot left shoulders, and 14-foot right shoulders. The westbound bridge would be widened toward the median and the eastbound bridge would be widened to the outside shoulder so the bridges would, upon expansion, be spaced approximately 12 feet apart. This distance could accommodate snoopers trucks for bridge inspection purposes. **Figure 8-4** shows the existing typical section and **Figure 8-5** shows the recommended typical section of the bridge.



Figure 8-4: Existing Willoughby Bay Bridge Typical Section Looking Eastbound

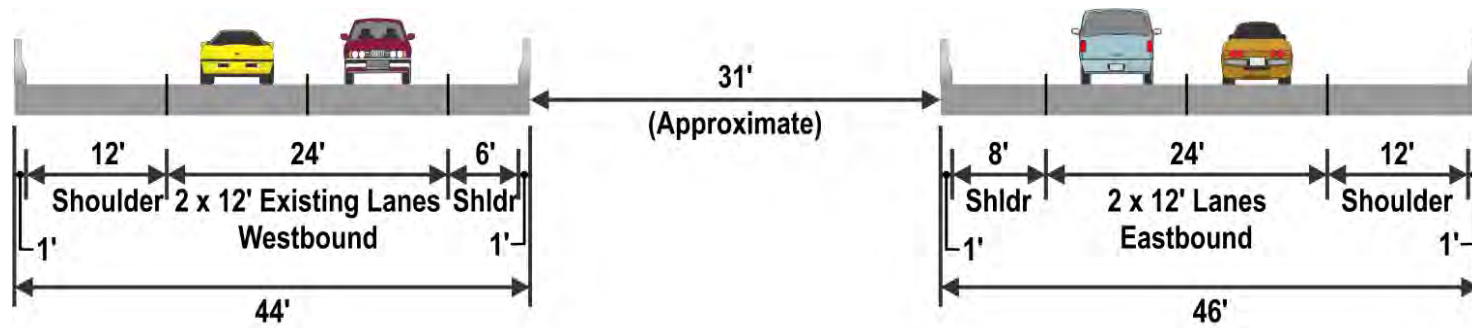
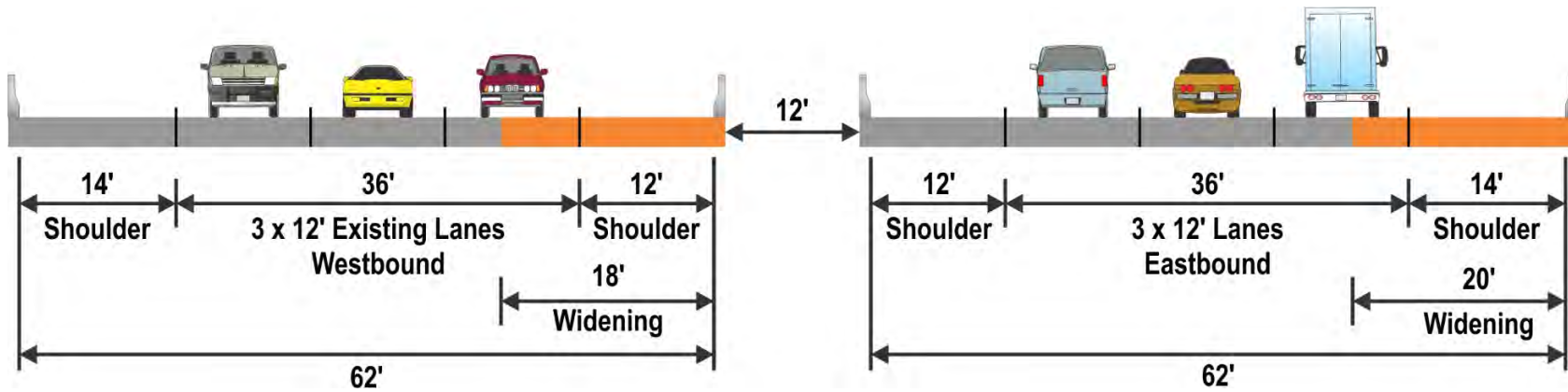

Figure 8-5: Proposed Willoughby Bay Bridge Typical Section Looking Eastbound



## Modification of Bayville Street

Bayville Street travels parallel to I-64 along the south side of Willoughby Spit, and provides connectivity between the existing right-in/right-out ramp movements along both eastbound and westbound I-64 at Exit 272 – West Ocean Avenue. Bayville Street is approximately 40 feet wide and includes one travel lane and one parking lane in each direction.

Improvements to I-64 would impact Bayville Street and would require shifting the roadway to the west. This would impact approximately eight residential properties along Bayville Street.

## 8.2 INTERSTATE 664

The Build Alternatives in the I-664 Study Area Corridor offer a differing number of mainline lanes along I-664 from I-64 to I-264. No-Build typical sections are shown in **Figure 8-6**, proposed typical sections are shown for Alternative C in **Figure 8-7**, proposed typical sections are shown for Alternative D in **Figure 8-8**, and plan sheets are provided in **Appendix A**. I-664 is broken down into ten alignment segments which are described below.

### 8.2.1 Segment 7C: Interstate 664 from Interstate 64 to Terminal Avenue Interchange

Through this segment of the I-664 Study Area Corridor, Alternative C would require two lanes of widening in each direction. One lane would be for general purpose traffic and one lane would be dedicated for transit use. See **Figure 8-7** for more detail.

In the southbound direction, the existing merge lane coming from the I-64 interchange would be converted to a lane addition. The second lane would be created by converting the merge lane to an additional lane at the Powhatan Parkway interchange.

In the northbound direction, one lane would be dropped at the Powhatan Parkway interchange, and four lanes would continue to the I-64 interchange.

The typical section would include 12-foot travel lanes, 12-foot inside shoulders, 14-foot shoulders, and a concrete barrier between the eastbound and westbound lanes. The inside shoulder would be widened from 8 feet to 12 feet to meet the geometric design criteria described in **Section 6**. The total pavement width of the proposed improvements would range from 25 to 80 feet of outside pavement widening on both sides of the highway.

Interchange improvements at Exit 2 – Powhatan Parkway; Exit 3 – Aberdeen Road; and Exit 4 – Chestnut Avenue would include adjusting the ramp gore areas to accommodate the widened mainline.

At Exit 5 – Warwick Boulevard/34<sup>th</sup> Street/35<sup>th</sup> Street and Exit 6 – 26<sup>th</sup> Street/27<sup>th</sup> Street, all roadway widening would be shifted to the east to minimize impacts to the existing ramps. Improvements to the interchange would include reconstructing the existing northbound I-664 to westbound 35<sup>th</sup> Street loop ramp at Exit 5 with a larger radius due to the widened roadway section. Consequently, the intersection of 35<sup>th</sup> Street and Jefferson Avenue would be shifted one block south to 34<sup>th</sup> Street and Jefferson Avenue.

Sound walls exist in many locations along this segment and would be replaced in kind unless noise analysis determines greater mitigation is necessary.

**Figure 8-6: I-664 No-Build Typical Sections**

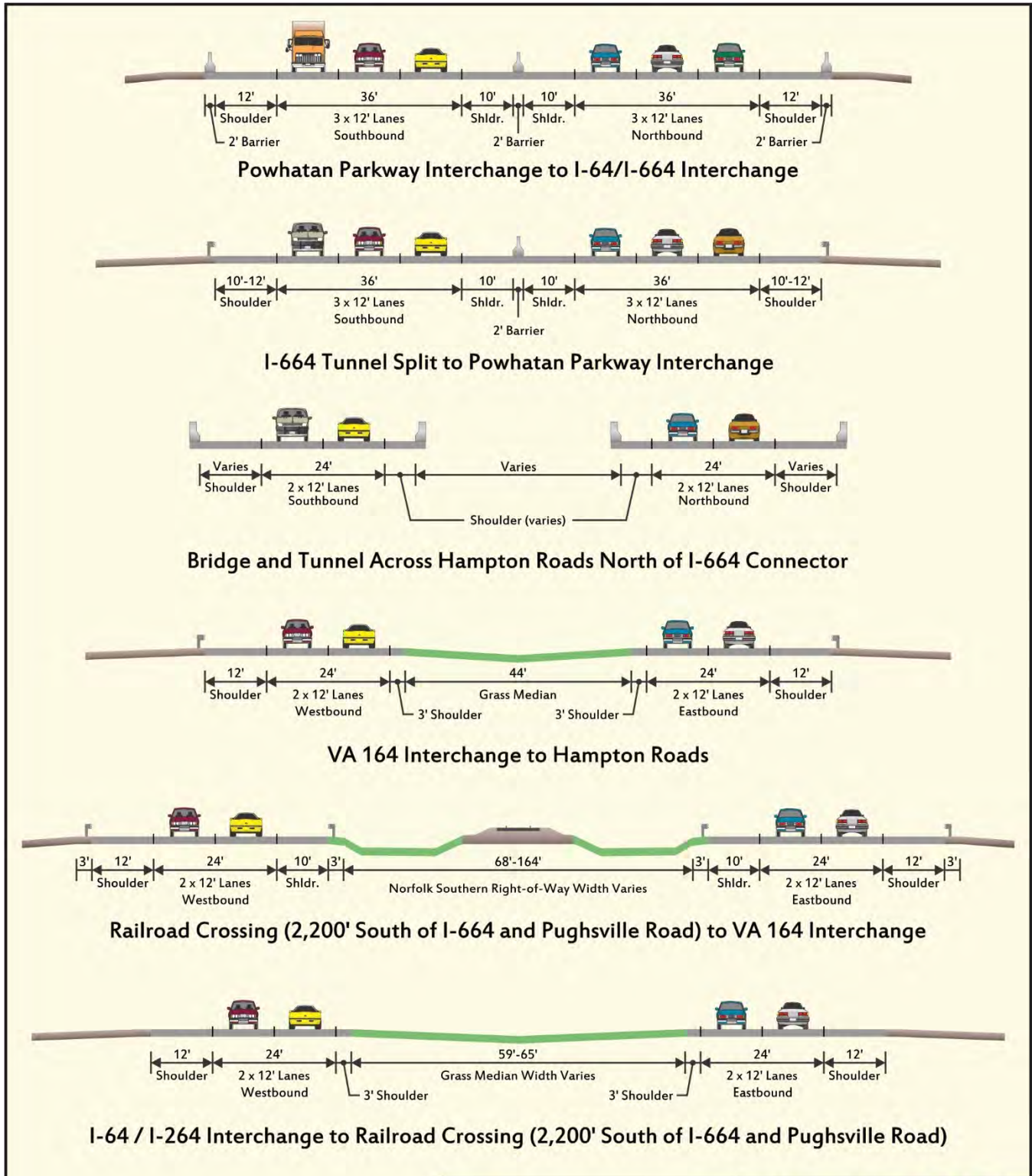

Not to scale

**LEGEND**

Existing Roadway



**HRCS SEIS**  
Hampton Roads Crossing Study SEIS  
**I-664 No-Build  
Typical Sections**

Figure 8-7: I-664 Alternative C Proposed Typical Sections

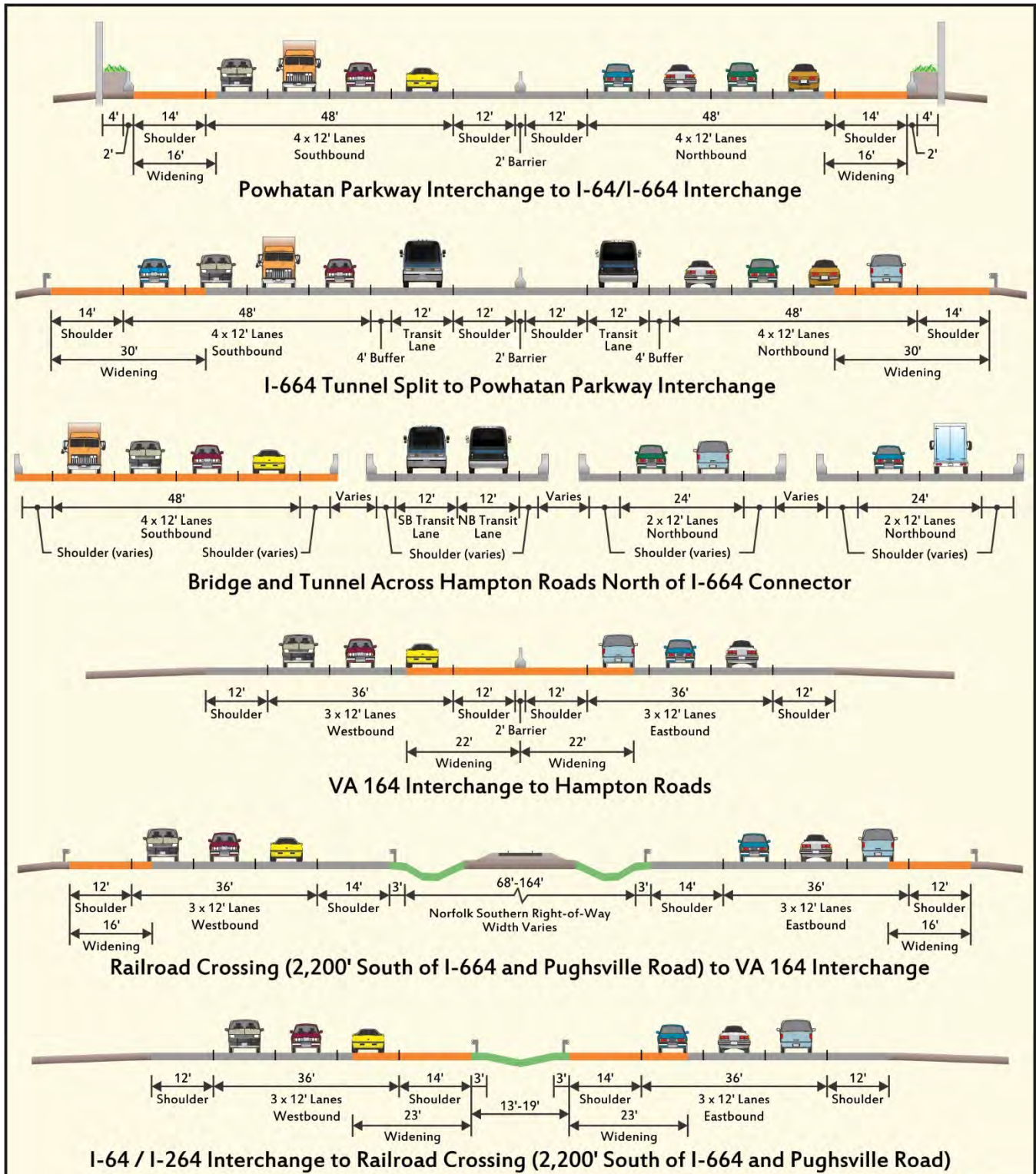

Not to scale

**LEGEND**

- Existing Roadway
- Widening



**HRCS SEIS**  
Hampton Roads Crossing Study SEIS  
**I-664 Proposed  
Typical Sections  
Alternative C**

**Figure 8-8: I-664 Alternative D Proposed Typical Sections**

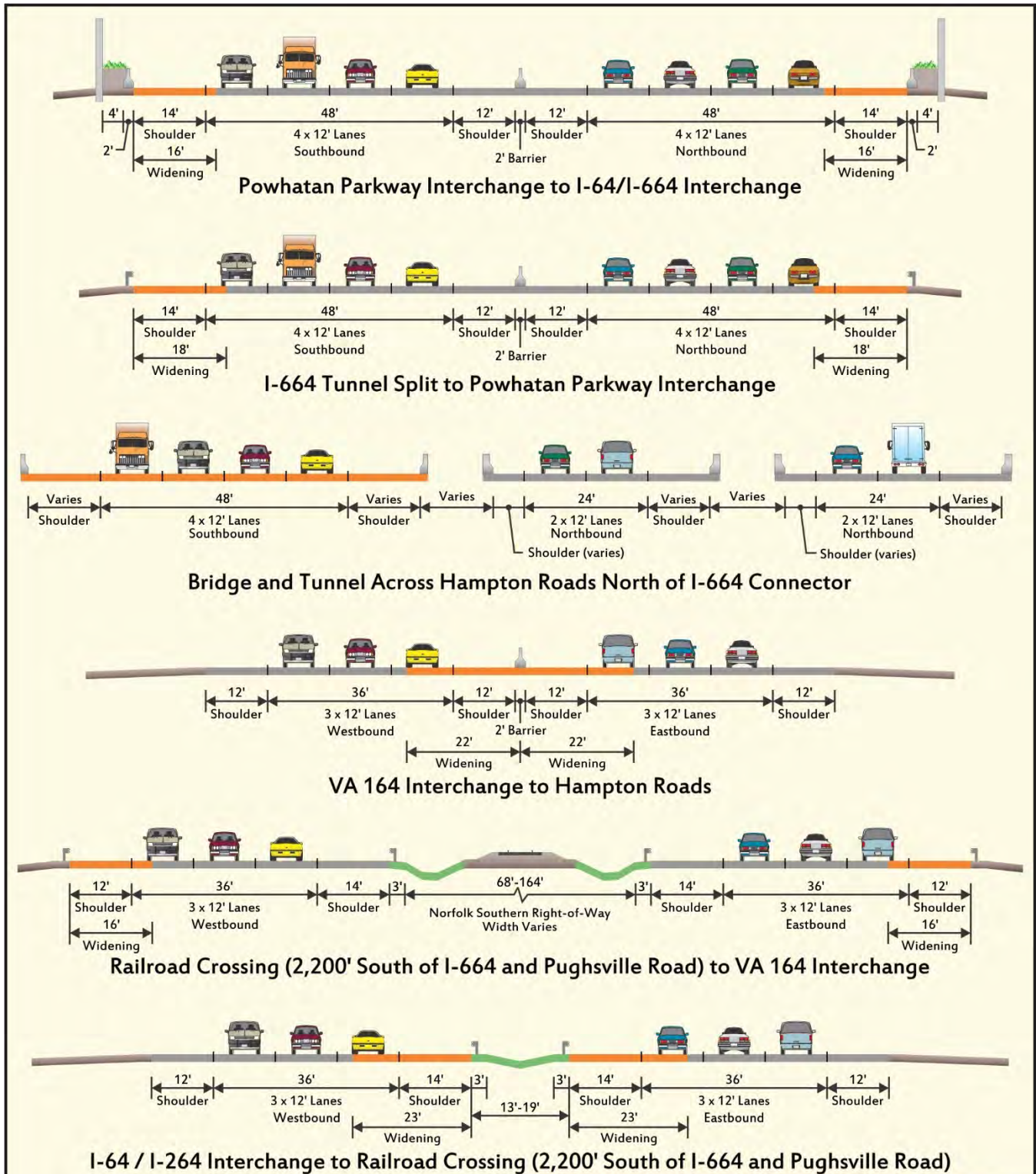

Not to scale

**LEGEND**

- Existing Roadway
- Widening



**HRCS SEIS**  
Hampton Roads Crossing Study SEIS  
**I-664 Proposed Typical Sections Alternative D**

### 8.2.2 Segment 7D: Interstate 664 from Interstate 64 to Terminal Avenue Interchange

Through this segment of the I-664 Study Area Corridor, Alternative D would require one lane of widening in each direction for general purpose traffic. See **Figure 8-8** for more detail.

In the southbound direction, the existing merge lane at the eastbound I-64 interchange would be converted to a lane addition. In the northbound direction, four lanes would continue to the I-64 interchange.

The total pavement width of the proposed improvements would range from 25 to 68 feet of outside pavement widening on both sides of the highway.

Interchange improvements at Exit 2 – Powhatan Parkway; Exit 3 – Aberdeen Road; and Exit 4 – Chestnut Street would include adjusting the ramp gore areas to accommodate the widened mainline.

At Exit 5 – Warwick Boulevard/34<sup>th</sup> Street/35<sup>th</sup> Street and Exit 6 – 26<sup>th</sup> Street/27<sup>th</sup> Street, all roadway widening is shifted to the east to minimize impacts to the existing ramps on the southbound roadway. Improvements to the interchange would include reconstructing the existing northbound I-664 to westbound 35<sup>th</sup> Street loop ramp at Exit 5 with a larger radius due to the widened roadway section. Consequently, the intersection of 35<sup>th</sup> Street and Jefferson Avenue would be shifted one block south to 34<sup>th</sup> Street and Jefferson Avenue.

Sound walls exist in many locations along this segment and would be replaced in kind unless noise analysis determines greater mitigation is necessary.

### 8.2.3 Segment 6C: Terminal Avenue Interchange

Through this segment of the I-664 Study Area Corridor, Alternative C would require two lanes of widening in each direction. One lane would be for general purpose traffic and one lane would be dedicated for transit use. See **Figure 8-7** for more detail.

At the Terminal Avenue interchange, the mainline travel lanes are elevated on structure. The southbound roadway would separate from the northbound roadway and begin to transition to the location of the new tunnel portal on a new roadway that would be located to the west of the existing Blue Night Energy Partners fuel tank facility. Widening for the northbound roadway would be accommodated on the existing southbound travel lanes.

### 8.2.4 Segment 6D: Terminal Avenue Interchange

Through this segment of the I-664 Study Area Corridor, Alternative D would require one lane of widening in each direction for general purpose traffic. See **Figure 8-8** for more detail.

Segment 6D would follow the same alignment as Segment 6C with the reduction of one transit lane per direction.

### 8.2.5 Segment 5C: Interstate 664 from Terminal Avenue Interchange to Interstate 664 Connector

Through this segment of the I-664 Study Area Corridor, Alternative C would require two lanes of widening in each direction. One lane would be for general purpose traffic and one lane would be dedicated for transit use.

This segment would include a new tunnel adjacent to the existing MMMBT. The new tunnel is described in **Section 10.8**.

### **8.2.6 Segment 5D: Interstate 664 from Terminal Avenue Interchange to Interstate 664 Connector**

Through this segment of the Study Area Corridor, Alternative D would require one lane of widening in each direction for general purpose traffic.

This segment would include a new tunnel adjacent to the existing MMMBT, which is described in **Section 10.8**.

### **8.2.7 Segment 4: Interstate 664 from Interstate 664 Connector to Virginia 164**

Through this segment of the I-664 Study Area Corridor, Alternatives C and D are the same. See **Figure 8-7** for more detail.

The existing southbound approach bridge would be used for northbound traffic to create four northbound travel lanes, and a new approach bridge would be constructed approximately 35 feet to the west of the existing bridge to accommodate four southbound travel lanes. The new bridge would include four 12-foot travel lanes and 14-foot shoulders. Trucks traveling northbound would be required to use the existing northbound approach bridge due to the proximity of the existing truck weigh and inspection station.

South of the MMMBT, roadway improvements would include two lanes of widening in each direction plus geometric modifications needed to tie into the new southbound MMMBT. The typical section would include 12-foot travel lanes and 14-foot shoulders and the northbound and southbound directions would be separated by a concrete traffic barrier. The inside shoulder would be widened from 8 feet to 12 feet to meet the geometric design criteria described in **Section 6**. The proposed improvements would include up to 25 feet of outside pavement widening on both sides of the highway and widening into the existing 50-foot grass median.

Interchange improvements at Exit 8 – College Drive/VA 135 would include adjusting the ramp gore areas to accommodate the widened mainline. No major interchange reconfigurations are proposed.

### **8.2.8 Segment 3: Interstate 664 and Virginia 164 Interchange**

Through this segment of the I-664 Study Area Corridor, Alternatives C and D are the same. The proposed design would replace the existing loop ramp from northbound I-664 to westbound VA 164/westbound US Route 17 with a directional flyover ramp. This change would eliminate the weaving movement between ramps on northbound I-664. The alternative would also replace the existing loop ramp from westbound VA 164/westbound US 17 to southbound I-664 with a directional flyover ramp, which would eliminate the weaving movement between ramps on westbound VA 164. The directional ramps would include a 16-foot wide travel lane, 4-foot paved left shoulders, and 8-foot paved right shoulders to meet the geometric design criteria described in **Section 6**.

Through this interchange area, the mainline of I-664 would transition from two lanes of widening to one lane of widening in each direction. Traveling southbound on I-664, the fourth lane would drop at the exit ramp to eastbound VA 164 and three lanes would continue south. Traveling northbound on I-664, three lanes are carried through the interchange area, and the fourth lane would be added at the entrance ramp from westbound VA 164.

### **8.2.9 Segment 2: Interstate 664 from Virginia 164 to US 58 (Bowers Hill)**

Through this segment of the Study Area Corridor, Alternatives C and D are the same and would require one lane of widening in each direction. See **Figure 8-7** for more detail.

The typical section would include 12-foot travel lanes and 12-foot outside shoulders. The inside shoulders would be widened from 3 feet to 14 feet plus guardrail to meet the geometric design criteria described in **Section 6**. The proposed improvements would include up to 25 feet of inside widening on both sides of the highway into the existing 66-foot grass median.

Interchange improvements at Exit 10 – Pughsville Road/VA 659; Exit 11 – Portsmouth Boulevard/VA 337; and Exit 12 – Dock Landing Road would include adjusting the ramp gore areas to accommodate the widened mainline. No major interchange reconfigurations are proposed.

#### **8.2.10 Segment 1: Interstate 664 from US 58 (Bowers Hill) to Interstate 264**

Through this segment of the Study Area Corridor, Alternatives C and D are the same and would require one lane of widening in each direction. See **Figure 8-7** for more detail.

The typical section would include 12-foot travel lanes and 12-foot outside shoulders. The inside shoulders would be widened from 3 feet to 14 feet plus guardrail to meet the geometric design criteria described in **Section 6**. The proposed improvements would include up to 23 feet of inside widening on both sides of the highway into the existing 66-foot grass median.

Traveling southbound on I-664, the additional lane would be dropped at the Military Highway interchange, where the existing exit ramp would be converted to a lane drop. Traveling northbound on I-664 the additional lane would be added at the merge between I-664 and Military Highway.

As part of this study, no major interchange reconfigurations are considered. However, the LOD has been set outside of the existing interchange footprint in order to account for any future interchange design.

### **8.3 INTERSTATE 664 CONNECTOR**

The I-664 Connector would be a new roadway that would connect I-664 to the proposed I-564 Connector and VA 164 Connector, described in **Section 8.4** and **Section 8.5**, respectively. The I-664 Connector would diverge from I-664 just south of the tunnel portals of the MMBT, and travel east on structure over the Hampton Roads Harbor until it intersects with the proposed interchange with the I-564 Connector and the VA 164 Connector.

Typical sections are shown in **Figure 8-9** for Alternatives C and D and plan sheets are provided in **Appendix A**. The I-664 Connector is broken into two alignment segments which are described below.



**Figure 8-9: I-664 Connector Alternative C and D Typical Sections**

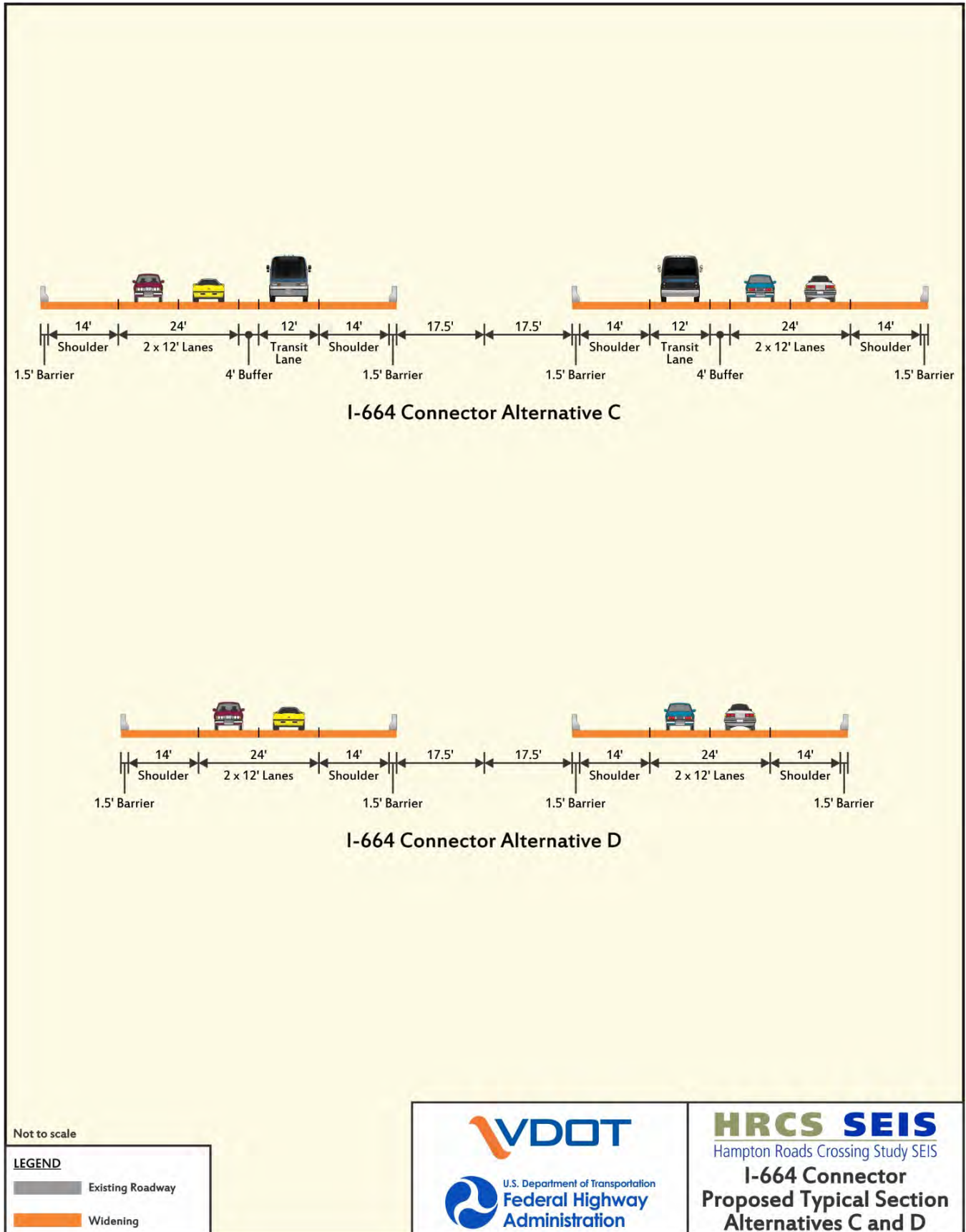

### 8.3.1 Segment 11C: Interstate 664 Connector including Interchange with Interstate 664

Through this segment of the I-664 Connector Study Area Corridor, Alternative C would include two new travel lanes plus one transit lane in each direction. This segment would be entirely on structure, and the travel lanes would be 12 feet wide and include 14-foot wide shoulders to meet the geometric design criteria described in **Section 6**.

On April 29, 2016, VDOT requested comments from USACE on the proposed alternatives relative to Section 408 of the Rivers and Harbors Act of 1899. In its response dated June 29, 2016, USACE stated that it will require continued unconstrained navigable access to CIDMMA (USACE, 2016). In addition, USACE stated plans should be developed to at least 60% completion before the Section 408 review and approval could occur. The proposed I-664 Connector bridge is currently designed to provide 100 feet of vertical clearance across an 800-foot wide channel to the CIDMMA. While it remains undetermined as to whether these dimensions meet USACE's need for unconstrained access, this segment does provide a potential scenario required to achieve the necessary clearance. If this section is included as part of a Preferred Alternative, any information included in the Final SEIS would remain conceptual until final design plans are advanced to permitting. A final bridge height for any structure would not be set until the USCG has issued a bridge permit. The timeline for this permitting process would depend on the given Operationally Independent Section and/or bridge structure that was being advanced. In the case of the I-664 Connector, USACE review under Section 408 would occur prior to a USCG permit. This review would determine if unconstrained navigable access to CIDMMA had been provided.

A new interchange would connect I-664 to the I-664 Connector. Upon exiting from the tunnel, southbound general purpose traffic wishing to head east would exit onto a flyover ramp to the I-664 Connector. Southbound transit-only lanes would also be directed to the I-664 Connector and would not continue south on I-664.

General purpose traffic traveling westbound on the I-664 connector would either head northbound onto I-664 via a directional ramp or southbound onto I-664 via a flyover ramp. Transit-only lanes would be directed to northbound I-664.

**Figure 8-10** shows the proposed interchange improvements for Alternative C.

Figure 8-10: I-664 / I-664 Connector Interchange, Alternative C

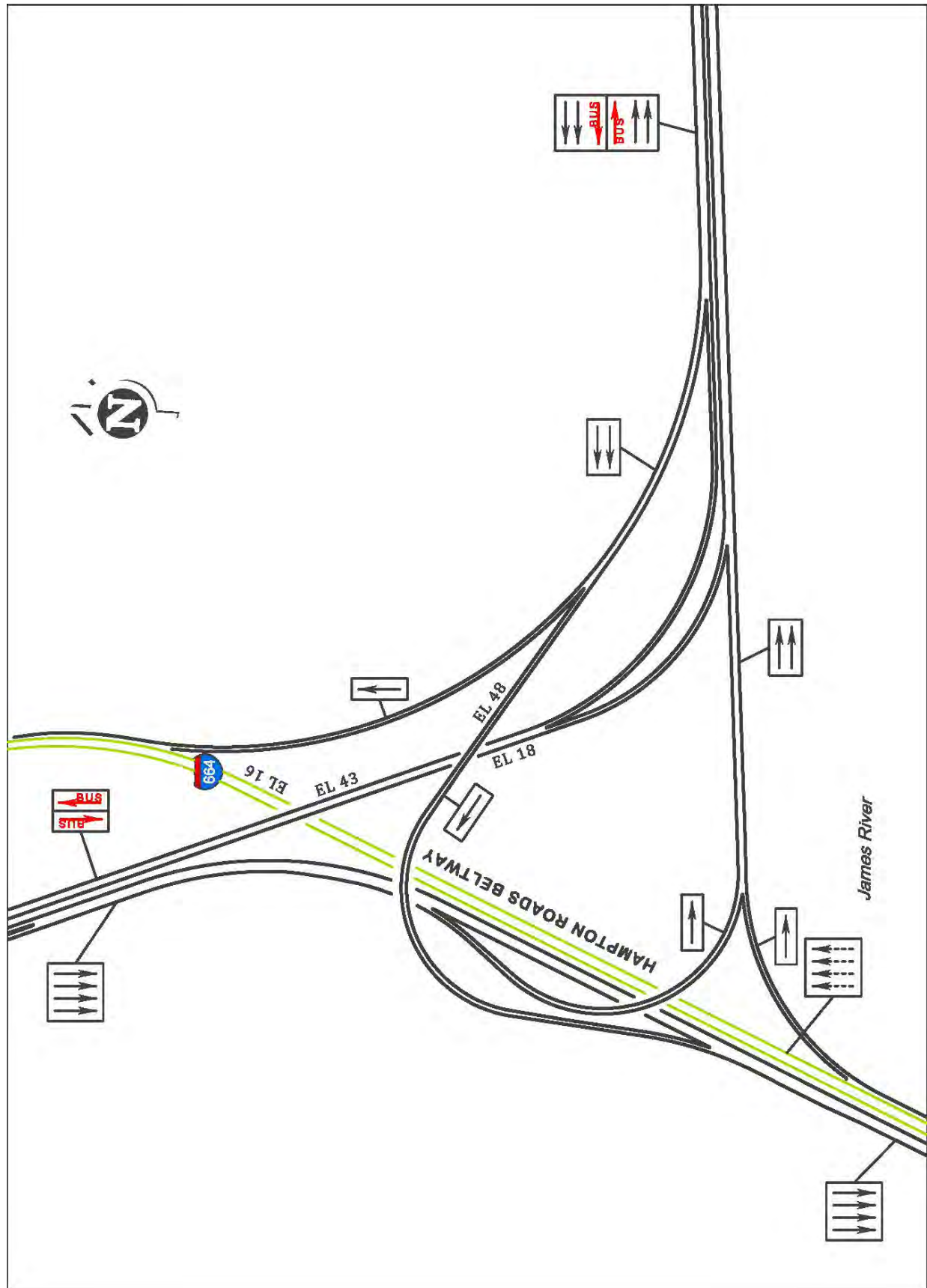

### **8.3.2 Segment 11D: Interstate 664 Connector including Interchange with Interstate 664**

Through this segment of the I-664 Connector Study Area Corridor, Alternative D would include two new travel lanes in each direction.

On April 29, 2016, VDOT requested comments from USACE on the proposed alternatives relative to Section 408 of the Rivers and Harbors Act of 1899. In its response dated July 29, 2016, USACE stated that it will require continued unconstrained navigable access to CIDMMA (USACE, 2016). In addition, USACE stated plans should be developed to at least 60% completion before the Section 408 review and approval could occur. The proposed I-664 Connector bridge is currently designed to provide 100 feet of vertical clearance across an 800-foot wide channel to the CIDMMA. While it remains undetermined as to whether these dimensions meet USACE's need for unconstrained access, this segment does provide a potential scenario required to achieve the necessary clearance. If this section is included as part of a Preferred Alternative, any information included in the Final SEIS would remain conceptual until final design plans are advanced to permitting. A final bridge height for any structure would not be set until the USCG has issued a bridge permit. The timeline for this permitting process would depend on the given Operationally Independent Section and/or bridge structure that was being advanced. In the case of the I-664 Connector, USACE review under Section 408 would occur prior to a USCG permit. This review would determine if unconstrained navigable access to CIDMMA had been provided.

A new interchange would connect I-664 to the I-664 Connector. Upon exiting from the tunnel, southbound general purpose traffic wishing to head east would exit onto a flyover ramp to the I-664 Connector.

General purpose traffic lanes traveling westbound on the I-664 connector would either head northbound onto I-664 via a directional ramp or southbound onto I-664 via a flyover ramp.

**Figure 8-11** shows the proposed interchange movements for Alternative D.

**Figure 8-11: I-664 / I-664 Connector Interchange, Alternative D**

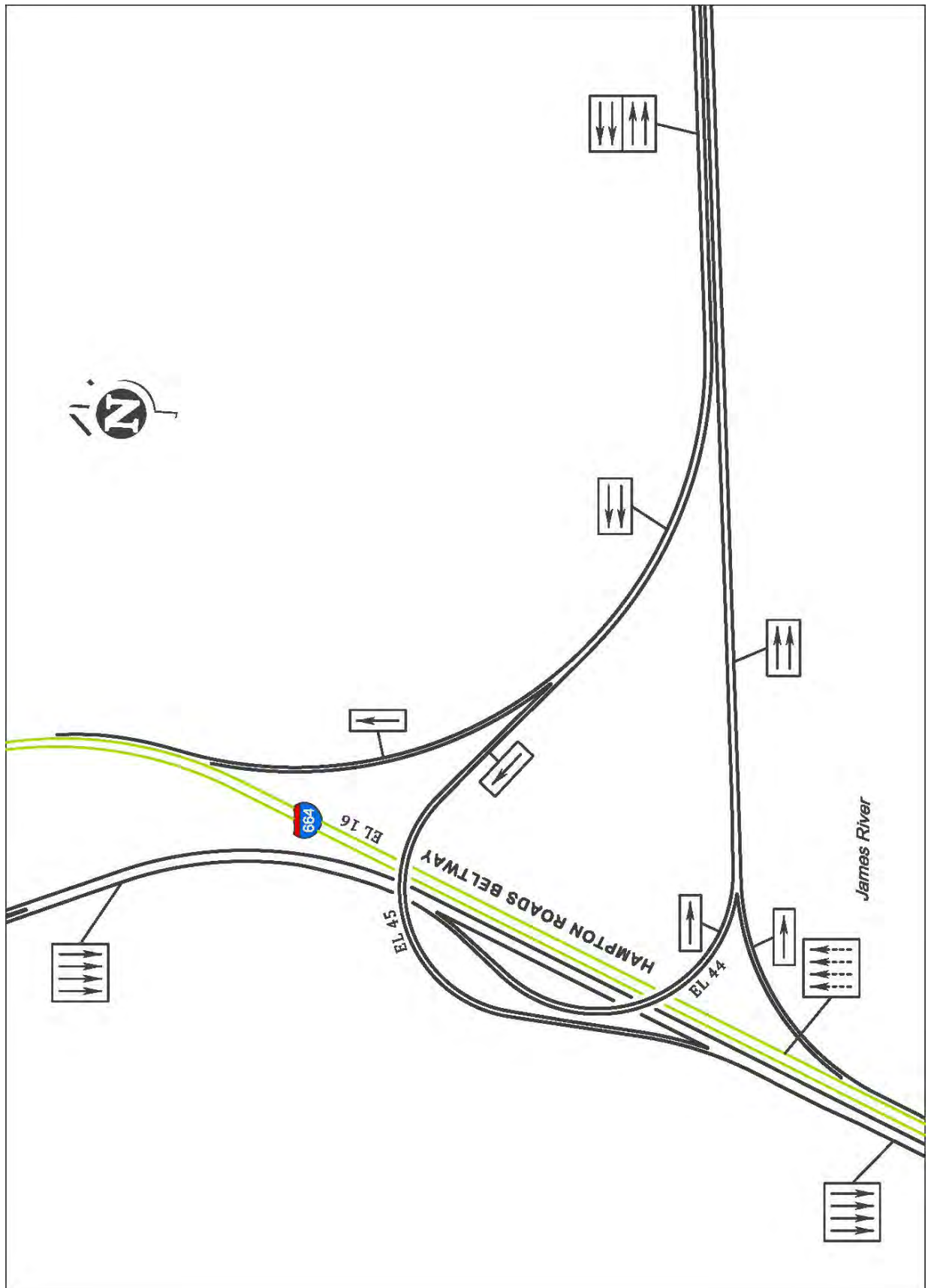

## 8.4 INTERSTATE 564 AND INTERSTATE 564 CONNECTOR

The I-564 Connector would be a new roadway that would connect the proposed I-664 Connector and the proposed VA 164 Connector, described in **Section 8.3** and **Section 8.5**, respectively, to I-564 and the new I-564 Intermodal Connector project, which is described in **Section 2.3**.

The I-564 Connector would include a new tunnel under the Norfolk Harbor Reach, which is described in detail in **Section 10.8**.

Typical sections are shown in **Figure 8-12** for Alternative C and in **Figure 8-13** for Alternatives B and D and plan sheets are provided in **Appendix A**. The I-564 Connector is broken into five alignment segments which are described below.

### 8.4.1 Segment 10B/D: Interstate 564 and Interstate 564 Connector

Through this segment of the I-564 Connector Study Area Corridor, Alternatives B and D are the same and would include two new travel lanes in each direction. The travel lanes would be 12 feet wide and include 12-foot wide shoulders to meet the geometric design criteria described in **Section 6**. See **Figure 8-13** for more detail.

Just east of the tunnel portal, the alignment would connect to the new I-564 IC alignment, a separate project currently under construction, which includes a partial Single Point Urban Diamond Interchange (SPUI) to provide access to Naval Station Norfolk (NAVSTA Norfolk) and Norfolk International Terminal (NIT) for westbound traffic. The I-564 Connector would complete the interchange movements by adding access from the eastbound I-564 Connector to NAVSTA Norfolk and NIT and to the westbound I-564 Connector from NAVSTA Norfolk and NIT. Traffic exiting the facilities would be able to travel eastbound or westbound on the I-564 Connector.

This proposed interchange would replace an interchange considered in the 2001 HRCS FEIS that provided a connection to Hampton Boulevard. This interchange is no longer feasible due to the construction of the I-564 IC and changes in the existing geometry of Hampton Boulevard. Should this Study Area Corridor be identified as part of the Preferred Alternative, the configuration and location of this interchange would be dependent on coordination with the US Navy and Port of Virginia and would be included in the Final SEIS.

The mainline of the I-564 Connector would cross over the entrance to NAVTSA Norfolk and NIT Hampton Boulevard on structure. It would be located in the median of the I-564 IC alignment, and merge into the I-564 IC alignment east of I-564. The I-564 IC would then merge into existing I-564.

### 8.4.2 Segment 10C: Interstate 564 and Interstate 564 Connector

Through this segment of the I-564 Connector Study Area Corridor, Alternative C would include two new general purpose travel lanes plus one transit lane in each direction. The travel lanes would be 12 feet wide and include 12-foot wide shoulders to meet the geometric design criteria described in **Section 6**. See **Figure 8-12** for more detail.

Just east of the tunnel portal, the alignment would connect to the new I-564 IC alignment, a separate project currently under construction, which includes a partial SPUI to provide access to NAVSTA Norfolk and NIT for westbound traffic. The I-564 Connector would complete the interchange movements by adding access from the eastbound I-564 Connector to NAVSTA Norfolk and NIT and to the westbound I-564 Connector from NAVSTA Norfolk and NIT. Traffic exiting the facilities would be able to travel eastbound or westbound on the I-564 Connector.

Figure 8-12: I-564 Connector Alternative C Typical Sections

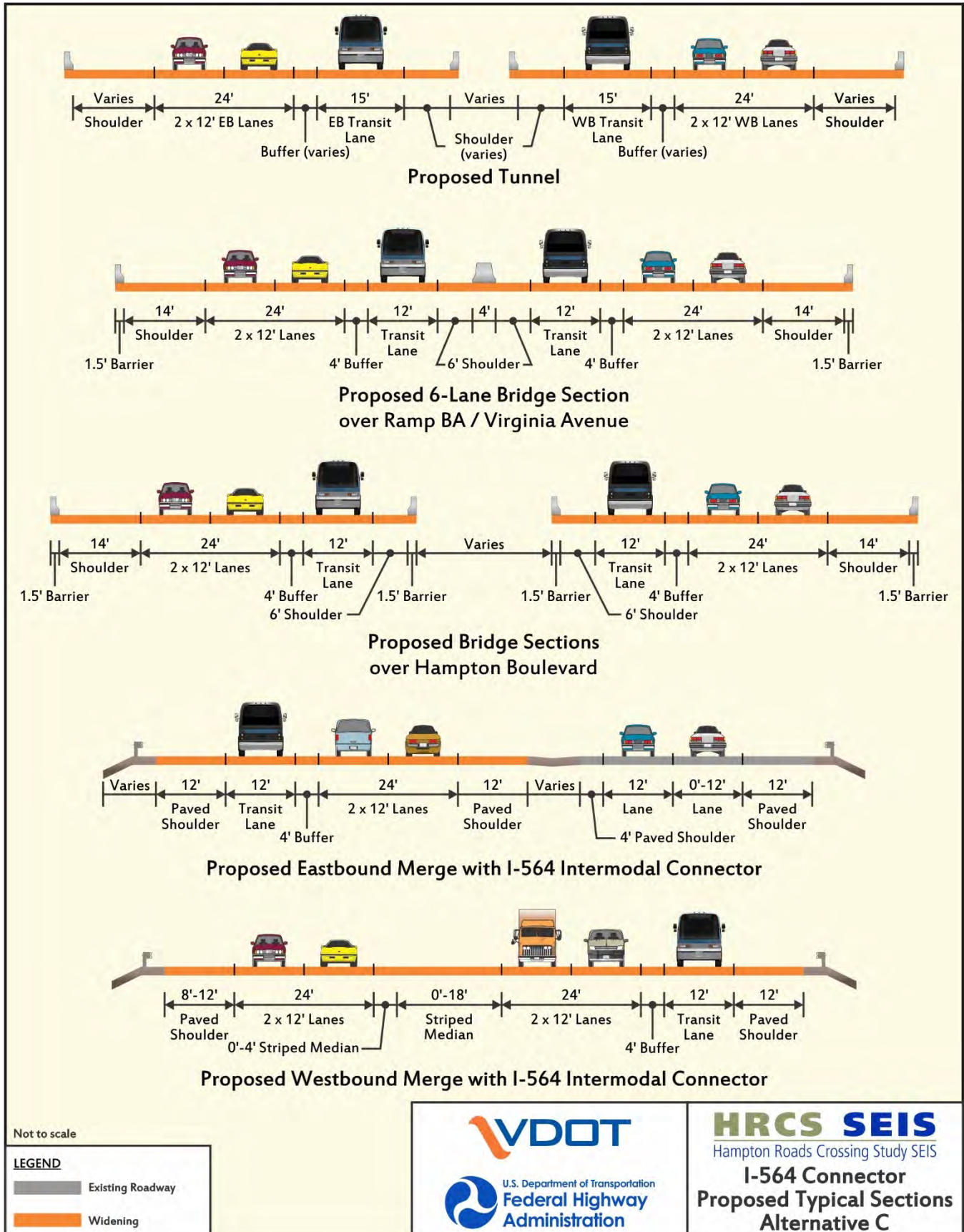

**Figure 8-13: I-564 Connector Alternatives B and D Typical Sections**

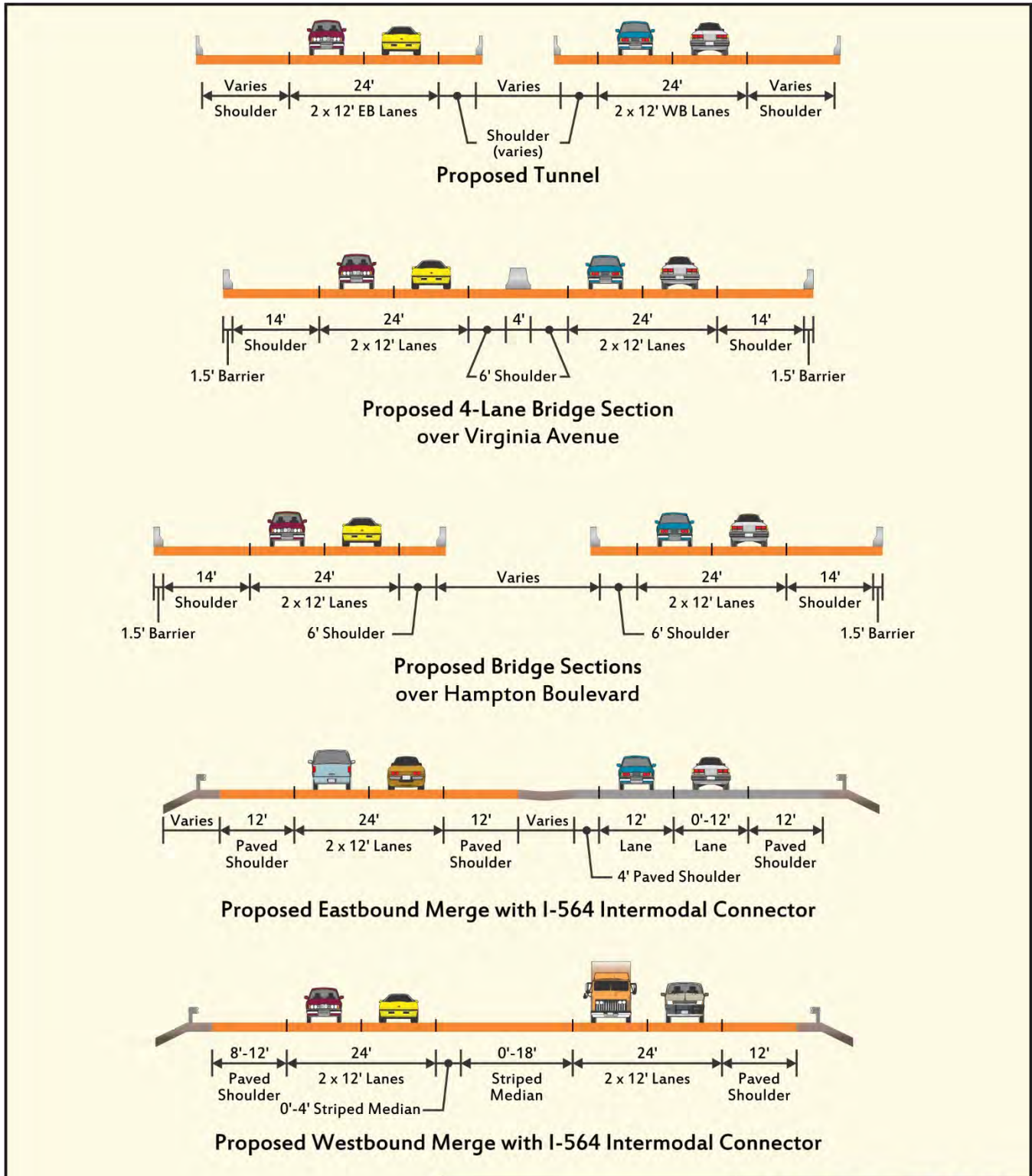

Not to scale

**LEGEND**

- Existing Roadway
- Widening

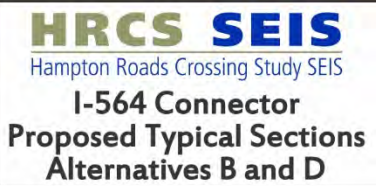



This proposed interchange would replace an interchange considered in the 2001 HRCS FEIS that provided a connection to Hampton Boulevard. This interchange is no longer feasible due to the construction of the I-564 IC and changes in the existing geometry of Hampton Boulevard. Should this Study Area Corridor be identified as part of the Preferred Alternative, the configuration and location of this interchange would be dependent on coordination with the US Navy and Port of Virginia and would be included in the Final SEIS.

The mainline of the I-564 Connector would cross over the entrance to NAVTSA Norfolk and NIT Hampton Boulevard on structure. It would be located in the median of the I-564 IC alignment.

The general purpose travel lanes would merge into the I-564 IC alignment east of I-564. The transit lanes would continue to I-564 and would merge into the existing HOV lanes which are located in the left travel lane on I-564. Transit vehicles traveling eastbound would access the HOV lane on I-564 using a directional flyover ramp. Transit vehicles traveling westbound in the HOV lane on I-564 would access the transit-only lane on the I-564 Connector using a directional flyover ramp. The existing travel lanes on I-564 would need to be reconstructed to accommodate the flyover ramps from the I-564 Connector.

#### **8.4.3 Segment 12B: Interstate 564 Connector and Virginia 164 Connector Interchange**

Alternative B would include two new travel lanes in each direction. This interchange segment would be entirely on structure, and the travel lanes would be 12 feet wide and include 14-foot wide shoulders to meet the geometric design criteria described in **Section 6**. A new interchange would connect the I-564 Connector to the VA 164 Connector.

#### **8.4.4 Segment 12C: Interstate 664 Connector, Interstate 564 Connector, and Virginia 164 Connector Interchange**

Alternative C would include two new travel lanes plus one transit lane in each direction. This interchange segment would be entirely on structure, and the travel lanes would be 12 feet wide and include 14-foot wide shoulders to meet the geometric design criteria described in **Section 6**.

The new interchange would connect the I-564 Connector to the I-664 Connector and the VA 164 Connector. Directional ramps would provide the movements from the eastbound I-664 Connector to the southbound VA 164 Connector and from the northbound VA 164 Connector to the eastbound I-564 Connector. Directional flyover ramps would provide movements from the westbound I-564 Connector to the southbound VA 164 Connector and from the northbound VA 164 Connector to the westbound I-664 Connector.

Transit lanes would continue from the I-664 Connector to the I-564 Connector, but would not continue south onto the VA 164 Connector.

#### **8.4.5 Segment 12D: Interstate 664 Connector, Interstate 564 Connector, and Virginia 164 Connector Interchange**

Alternative D would include two new travel lanes in each direction. This interchange segment would be entirely on structure, and the travel lanes would be 12 feet wide and include 14-foot wide shoulders to meet the geometric design criteria described in **Section 6**.

The new interchange would connect the I-564 Connector to the I-664 Connector and the VA 164 Connector. Directional ramps would provide the movements from the eastbound I-664 Connector to the southbound VA 164 Connector and from the northbound VA 164 Connector to the eastbound I-564 Connector. Directional flyover ramps would provide movements from the westbound I-564 Connector to

the southbound VA 164 Connector and from the northbound VA 164 Connector to the westbound I-664 Connector.

## **8.5 VIRGINIA ROUTE 164 CONNECTOR**

Alternatives B, C, and D would provide two continuous mainline lanes in each direction of the Virginia Route 164 (VA 164) Connector throughout the limits of the Study Area Corridor. Typical sections are shown in **Figure 8-14** and plan sheets are provided in **Appendix A**. The VA 164 Connector is included in one alignment segment which is described below.

### **8.5.1 Segment 13: Virginia 164 Connector**

Alternatives B, C, and D would include two new travel lanes in each direction. The travel lanes would be 12 feet wide and include 12-foot wide shoulders at-grade and 14-foot wide shoulders on structure to meet the geometric design criteria described in **Section 6**. See **Figure 8-14** for more detail.

In 2006, the USACE issued a Feasibility Study and Environmental Impact Statement for an eastward expansion of the CIDMMA to resolve projected dredged material capacity issues and provide a new marine terminal site on the expanded area. The CIDMMA expansion is currently underway with diversion dikes under construction in 2016. The marine terminal site is expected to be operational in the late 2020s/early 2030s depending on funding authorization (Port of Virginia, 2015b). The VA 164 Connector would traverse the east side of the existing CIDMMA. The CIDMMA expansion extends to the east of the proposed roadway. Plans for the proposed eastward expansion included right-of-way for the VA 164 Connector. The proposed horizontal alignment for this segment is consistent with this plan for right-of-way. If this Study Area Corridor is identified as part of a Preferred Alternative, additional coordination would occur with USACE, USCG, US Navy, and the Virginia Port Authority to determine required elevations and alignments of the structure to accommodate the agencies' security and access needs. These modifications could impact the cost of the alignment. Information regarding the proposed elevations would be included in the Final SEIS, however, final elevations and alignments would not be confirmed until the design and permitting process. The timeline for this permitting process would depend on the order of implementation for a Preferred Alternative and available funding.

The 2006 USACE Feasibility Study included two interchanges along the VA 164 Connector to access the future port. They are not included as part of this SEIS, but the VA 164 Connector has been designed to accommodate them in the future.

The VA 164 Connector Study Area Corridor would also include the interchange with VA 164, which is described in **Section 8.6**. Directional flyover ramps would provide movements from eastbound VA 164 to northbound VA 164 Connector and from southbound VA 164 Connector to eastbound VA 164. Directional ramps would provide movements from westbound VA 164 to northbound VA 164 Connector and from southbound VA 164 Connector to westbound VA 164. The existing VA 164 interchange with VIG Boulevard would be reconfigured due to its proximity to the proposed interchange. Collector-distributor (C-D) roads would be constructed to accommodate the ramp movements at the VA 164 interchange with the VA 164 Connector, the VA 164 interchange with VIG Boulevard, and the westbound entrance ramp to VA 164 from Cedar Lane.

To accommodate the ramp from eastbound VA 164 to northbound VA 164 Connector, a portion of Wild Duck Lane would be relocated. A cul-de-sac would be constructed along Wyatt Drive to accommodate the reconstruction of the VA 164 interchange with VIG Boulevard. Access would be provided via Norfolk Road.

**Figure 8-14: VA 164 Connector Typical Sections**

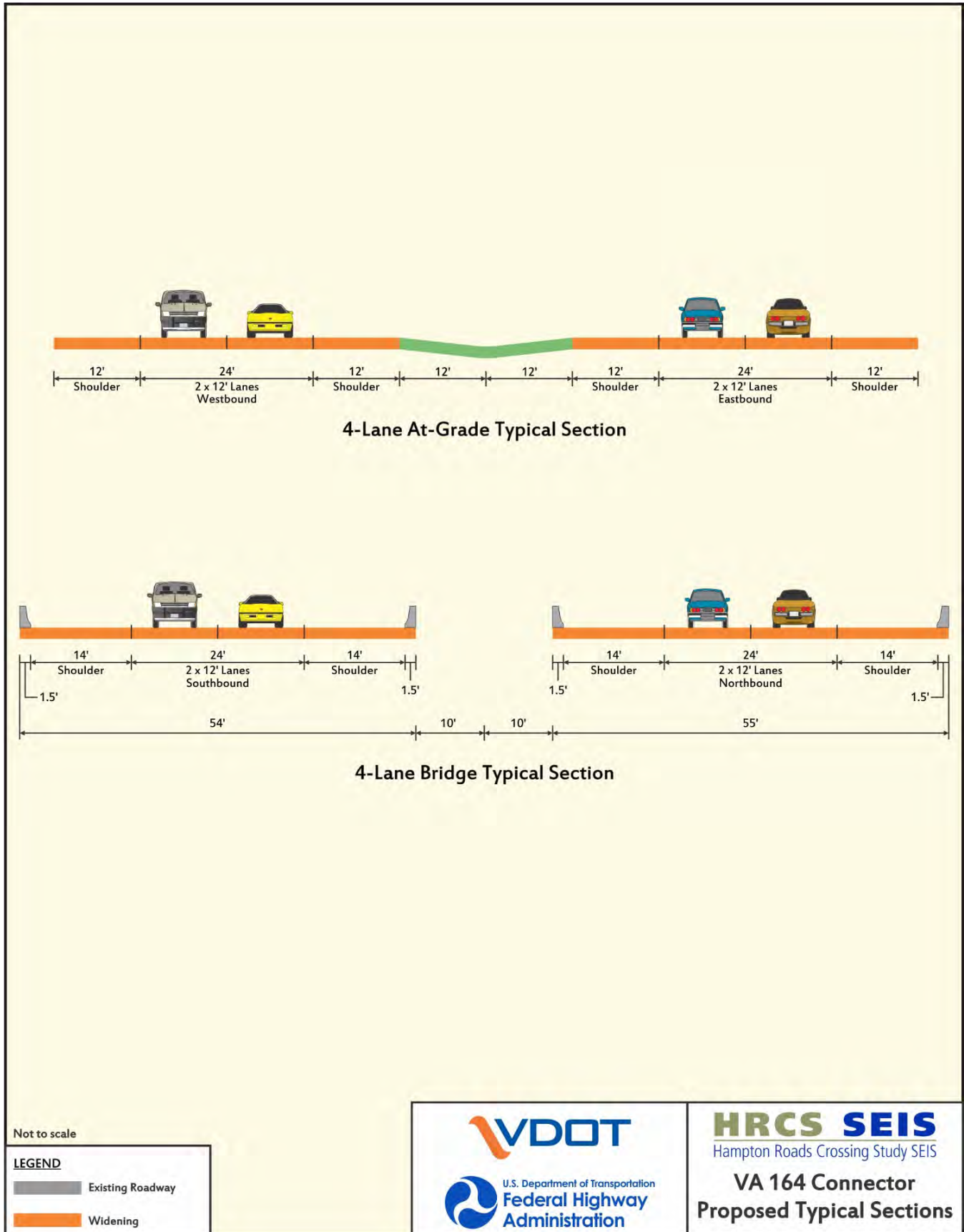

## **8.6 VIRGINIA ROUTE 164**

Alternatives B and D would provide six continuous mainline lanes in each direction of VA 164 throughout the limits of the VA 164 Study Area Corridor. No-Build typical sections are shown in **Figure 8-15**, proposed typical sections are shown in **Figure 8-16**, and plan sheets are provided in **Appendix A**. VA 164 is included in one alignment segment which is described below.

### **8.6.1 Segment 14: Virginia Route 164**

From the College Avenue interchange to the Cedar Lane interchange, widening would occur into the median. The existing median includes two Commonwealth Railway rail lines which operate on VDOT-owned property. A six-foot high, two and one-half foot wide crash wall would be constructed in each direction between the travel lanes and the rail lines.

Interchange improvements at VA 135/College Drive, Towne Point Road, and Cedar Lane would include adjusting the ramp gore areas to accommodate the widened mainline. No major interchange reconfigurations are proposed.

At the western edge of the VA 164 Study Area Corridor, at the I-664 interchange with VA 164, the third travel lane would be added in the eastbound direction by continuing the existing inside lane that currently drops at the I-664 northbound on-ramp. In the westbound direction, the third travel lane would exit onto I-664 as a lane drop.

At the eastern edge of the VA 164 Study Area Corridor, the proposed widening would tie into the improvements at the VA 164 and VA 164 Connector interchange, described in **Section 8.5**.

Because widening would occur to the median, the existing sound walls along the VA 164 Study Area Corridor would remain unless noise analysis determines greater mitigation is necessary.

**Figure 8-15: VA 164 No-Build Typical Sections**

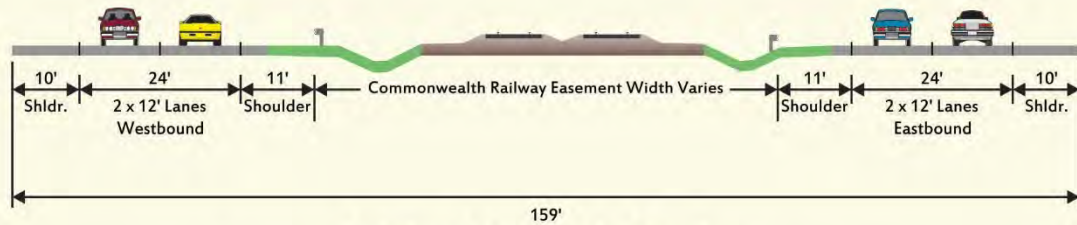

**Existing 4-Lane Typical Section**  
from College Drive Interchange to Towne Point Road Interchange

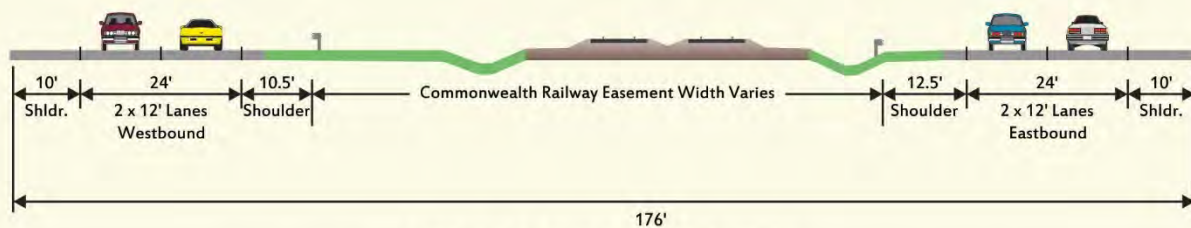

**Existing 4-Lane Typical Section**  
from Towne Point Road Interchange to Cedar Lane Interchange

Not to scale

**LEGEND**

Existing Roadway



**HRCS SEIS**  
Hampton Roads Crossing Study SEIS  
**VA 164 No-Build  
Typical Sections**

**Figure 8-16: VA 164 Proposed Typical Sections**

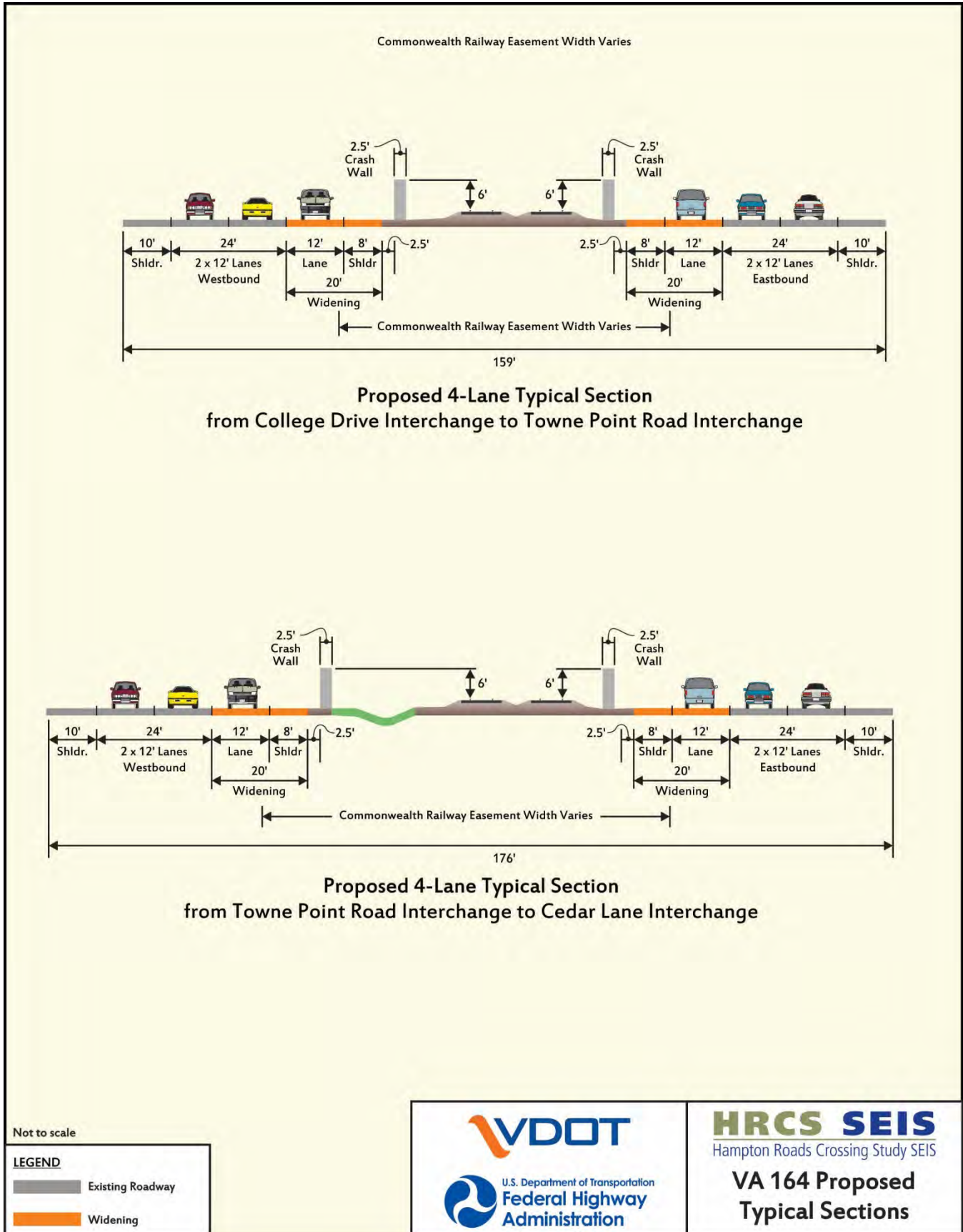

## 9. OPERATIONALLY INDEPENDENT SECTIONS

Given the magnitude and scope of the alternatives, it is expected that a Preferred Alternative would be implemented in stages or operationally independent sections (OISs). An OIS is a portion of an alternative that could be built and function as a viable transportation facility with a logical terminus even if other portions of the alternative are not advanced (FHWA, 2007). The OISs are comprised of various roadway alignments and were developed by identifying sections of roadway improvements that if constructed, could function independently. This means that a section of roadway improvements could be constructed and immediately opened to the travelling public. Part of this analysis included the evaluation of adjacent roadways and whether or not the proposed improvements would tie into existing roadways.

The VA 164 Connector by itself is not included in this Draft SEIS as an OIS, but could become an OIS should the CIDMMA site be constructed prior to the implementation of this portion of an alternative. If the CIDMMA site is not constructed, there is no logical termini along this corridor. Once constructed, this section or a portion of this section could be identified as an OIS. The impacts for the alternatives will be quantified based on roadway alignment sections as described in **Section 8**. The OISs are listed on **Table 9-1** below and shown on **Figure 9-1**.

**Table 9-1: Operationally Independent Sections**

OIS Number	OIS Name
I	I-664 from I-264 to US 58
II	I-664 from US 58 to VA 164
III	I-664 from VA 164 to MMMBT/Terminal Avenue Exit
IV	I-664 from MMMBT/Terminal Avenue Exit to I-64
V	I-64 from I-664 to Mallory Street Exit
VI	I-64 from Mallory Street Exit to I-564
VII	I-564, I-564 Connector, and I-664 Connector
VIII	I-564, I-564 Connector, and VA 164 Connector
IX	I-664 Connector and VA 164 Connector
X	VA 164 Connector
XI	VA 164

Figure 9-1: Operationally Independent Sections





## 9.1 POTENTIAL HYBRID ALTERNATIVES

Following the release of the Draft SEIS and an opportunity for public review and comment, the OISs could ultimately be combined to form “hybrid” alternatives. The OIS strategy described in **Section 9** allows for the identification of a “hybrid” alternative in addition to the alternatives described in this chapter that could reduce impacts and costs while achieving purpose and need. Depending on the nature of a hybrid alternative, if selected, public involvement opportunities may be offered to solicit additional public comment.

If a hybrid is identified as the Preferred Alternative, it would be presented to the public and fully documented in the Final SEIS. The cost and impact information in this Draft SEIS, however, provides preliminary information on potential hybrids.

## 9.2 PHASED IMPLEMENTATION APPROACH

The implementation of the Preferred Alternative could occur via the construction of OISs. Each alternative has been developed using OISs. Impacts for the alignment segments that make up the OISs have been provided in this Draft SEIS and respective technical documents.

Once the Preferred Alternative is properly documented in the Final SEIS and the first OIS or a group of OISs is included in the HRTPO Long-Range Transportation Plan, the HRTPO Transportation Improvement Program, and the Statewide Transportation Improvement Program, it is expected that VDOT would then request a ROD for the first OIS or a group of OISs from FHWA.

Once a ROD is issued for an OIS or group of OISs, that section would be advanced into the final engineering design phase. It is during this phase that design details including the precise disturbance limits, right-of-way requirements, certifications, and permits would be applied for. Certifications and permits would be obtained for items such as impacts to Waters of the United States, including wetlands, navigable waters, coastal zone management areas, stormwater management, and erosion and sediment control. Any necessary mitigation measures would also be finalized through coordination with the appropriate agencies.

The OISs would move into the right-of-way acquisition and utility relocation phases following final design. The acquisition of right-of-way would follow the most current state and federal regulations before construction would be initiated.

## 9.3 ORDER OF IMPLEMENTATION

The Final SEIS will include a proposed order of implementation for the Preferred Alternative. This will document the order in which VDOT anticipates requesting RODs from FHWA to allow the alternative to be implemented in OISs. The order of implementation presented below for each alternative is an example of how the Preferred Alternative could be presented in the Final SEIS, and is not meant to represent a recommended order. The final order for the Preferred Alternative will be informed by engineering and traffic analysis, public and agency comments, and resolutions passed by localities and groups.

### 9.3.1 Alternative A

An illustrative order of implementation of OISs for Alternative A is shown in **Table 9-2**.

**Table 9-2: Alternative A Order of Implementation**

OIS	Alignment Segments
VI	I-64 from Mallory Street Exit to I-564
V	I-64 from I-664 to Mallory Street Exit

**9.3.2 Alternative B**

An illustrative order of implementation of OISs for Alternative B is shown in **Table 9-3**.

**Table 9-3: Alternative B Order of Implementation**

OIS	Alignment Segments
VI	I-64 from Mallory Street Exit to I-564
V	I-64 from I-664 to Mallory Street Exit
VIII	I-564, I-564 Connector, and VA 164 Connector
XI	VA 164

**9.3.3 Alternative C**

An illustrative order of implementation of OISs for Alternative C is shown in **Table 9-4**.

**Table 9-4: Alternative C Order of Implementation**

OIS	Alignment Segments
III	I-664 from VA 164 to MMMBT/Terminal Avenue Exit
VII	I-564, I-564 Connector, and I-664 Connector
IV	I-664 from MMMBT/Terminal Avenue Exit to I-64
II	I-664 from US 58 to VA 164
I	I-664 from I-264 to US 58
X	VA 164 Connector

**9.3.4 Alternative D**

An illustrative order of implementation of OISs for Alternative D is shown in **Table 9-5**.

**Table 9-5: Alternative D Order of Implementation**

OIS	Alignment Segments
VI	I-64 from Mallory Street Exit to I-564
V	I-64 from I-664 to Mallory Street Exit
VIII	I-564, I-564 Connector, and VA 164 Connector
XI	VA 164
III	I-664 from VA 164 to MMMBT/Terminal Avenue Exit
IV	I-664 from MMMBT/Terminal Avenue Exit to I-64
II	I-664 from US 58 to VA 164
I	I-664 from I-264 to US 58
IX	I-664 Connector

## **10. ENGINEERING DETAILS OF ALTERNATIVES RETAINED**

The four Retained Alternatives include a variety of elements that contribute to the typical section and create the complete end-to-end alternatives including the roadside design and limit of disturbance (LOD); interchanges; landside structures; approach bridges to tunnels; tunnels; and the Willoughby Spit and Willoughby Bay bridges along I-64. These elements are explained in detail below.

### **10.1 ROADSIDE DESIGN AND LIMITS OF DISTURBANCE**

Several roadside design options were considered for the Build Alternatives in the HRCS including a full open section with a 6-to-1 slope, a guardrail section with 2-to-1 slope, a retaining wall section, a sound wall section, and a sound wall on retaining wall section. The roadside design options were applied to the proposed alternatives based on the existing roadside conditions and constraints. The LOD was developed for the mainline of the Build Alternatives using the proposed pavement width and the roadside design options as described in **Table 10-1** and shown in **Figure 10-1**. Stormwater Management was not developed to a level of detail great enough to identify locations for facilities; therefore, stormwater management is not included within the LOD. The LOD used to quantify environmental impacts will serve as the proposed right-of-way line where it is located outside of the existing right-of-way line. An additional four feet was included in the LOD to accommodate potential managed lanes such as HOV lanes or HOT lanes. All roadside design values meet VDOT and AASHTO design standards.

Existing roadways were widened to the median wherever possible to minimize impacts. In order to appropriately compare the Build Alternatives, design exceptions or minimization options were not evaluated as part of the Draft SEIS. Once a Preferred Alternative is identified, design refinements will be explored as part of the Final SEIS and extend into the design permitting stages to minimize impacts to sensitive environmental, cultural, or community resources.

**Table 10-1: Roadside Design Options**

Roadside Design	Description
Full Open Section with 6-to-1 Slope	This is the widest typical section and would include a full open section with 18 feet of clear zone from the edge of the shoulder at 6-to-1 slope; roadside grading at a 3-to-1 slope to tie to the existing ground; and a 30-foot offset to the LOD to accommodate drainage, utilities, stormwater management, and construction easements.
Guardrail Section with 2-to-1 Slope	This section would include guardrail that would allow for a three foot offset to the top of the 2-to-1 slope which would tie to existing ground, and a 30-foot offset to the LOD.
Closed/Barrier - Retaining Wall	This option would include a closed roadway section with a retaining wall at the edge of the shoulder and a 30-foot offset to the LOD.
Sound Wall on Retaining Wall	In constrained locations, a proposed sound wall could be placed on top of a retaining wall. This option would include a closed roadway section with a concrete barrier placed at the edge of the shoulder, the sound wall would be placed on top of the retaining wall 4 feet behind the back of the barrier. A 30-foot offset to the LOD would accommodate drainage, utilities, stormwater management, and construction easements.
Sound Wall	In locations where a sound wall is warranted, a concrete barrier would be placed at the edge of the shoulder and the sound wall placed 4 feet behind the back of the barrier. This four-foot offset would be backfilled with aggregate material. Behind the sound wall, 10-to-1 grading would tie to existing ground to accommodate maintenance vehicle access; and a 30-foot offset to the LOD would accommodate drainage, utilities, stormwater management, and construction easements.

Figure 10-1: Roadside Design Options

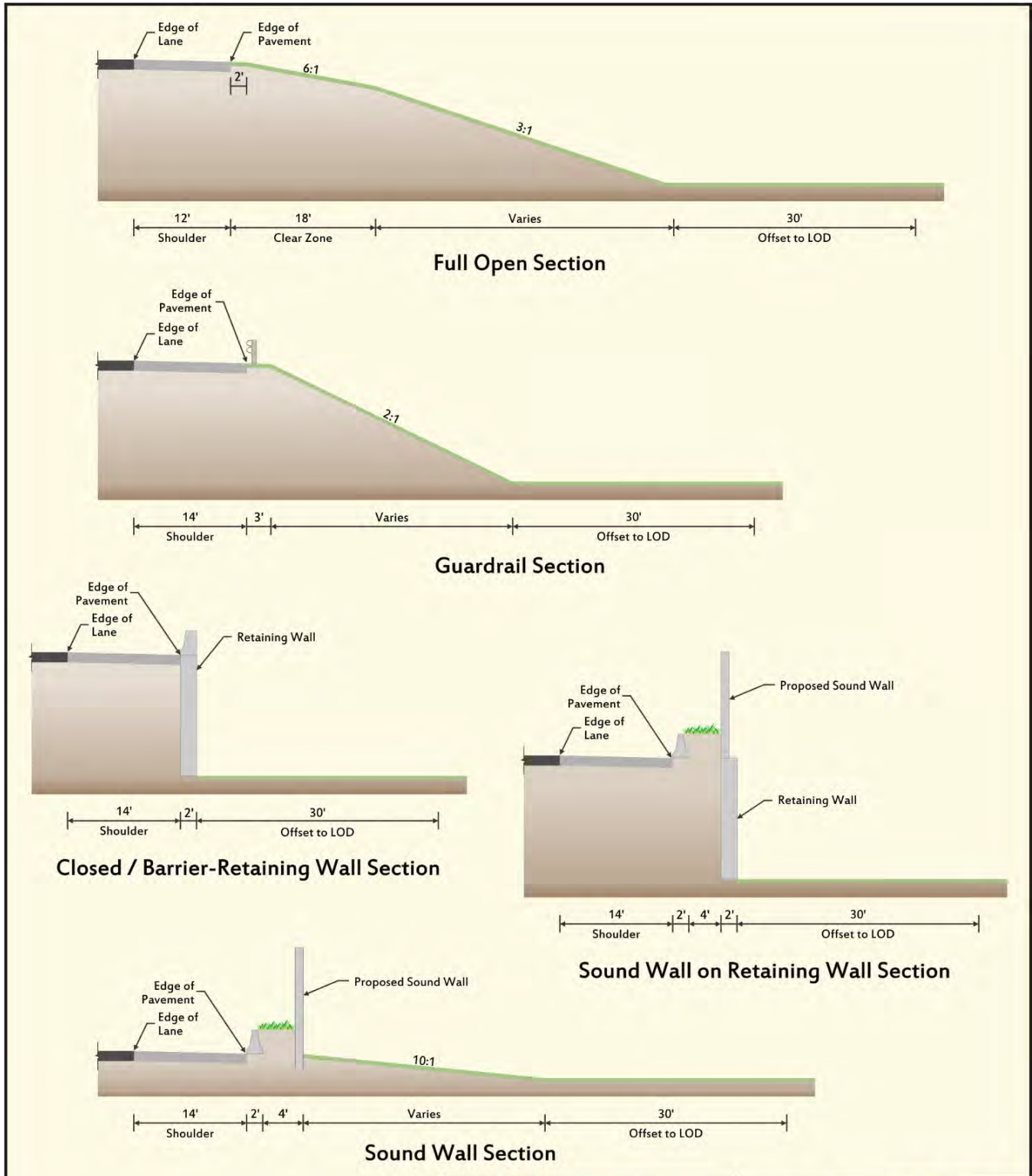

Not to scale

**LEGEND**

- Existing Roadway
- Widening



**HRCS SEIS**  
Hampton Roads Crossing Study SEIS

**Roadside Design Options**  
**Typical Sections**

## 10.2 BRIDGE AND TUNNEL LIMITS OF DISTURBANCE

### 10.2.1 Tunnel Limit of Disturbance

The LOD varies in width across the Hampton Roads Harbor due to the proposed tunnel configurations, the varying distance between the existing and proposed approach bridges and tunnels, and the amount of dredging potentially required to accommodate the construction of new approach bridges and tunnels. The LOD for the tunnel crossings was based on the following and includes the area between the existing tunnels and the proposed tunnels:

- I-64 Study Area Corridor: 560 feet
- I-664 Study Area Corridor: 1,340 feet
- I-564 Study Area Corridor: 540 feet

### 10.2.2 Portal Island Limit of Disturbance

The LOD around the portal islands was estimated by proposing an island similar in size and elevation to the existing portal islands for HRBT and MMMBT. 3:1 side slopes were used for the island fill slopes, and the river bottom was assumed to be 30 feet below MLW elevation based on as-built plans and NOAA maps. To ensure that there would be adequate space to accommodate detailed design and construction of the enlarged islands in the future, a 30-foot offset was established beyond the toe of island slopes.

### 10.2.2 Bridge Limit of Disturbance

A 30-foot offset was established beyond the bridge parapets for the LOD on structures over water to accommodate construction. A 110-foot offset was established beyond the bridge parapets for the LOD for the bridges along the I-664 Connector as described in **Sections 8.3.1 and 8.3.2** to accommodate construction.

## 10.3 INTERCHANGES

Preliminary concepts were investigated for the interchanges within the Study Area Corridors to accommodate the Build Alternatives. The interchange concepts could include adjustments to ramp gore areas to tie-in to the wider mainline, addition of lanes to accommodate future traffic volumes, realignment of ramps to meet the current VDOT and AASHTO design standards, and the removal of ramps to eliminate mainline weaving areas.

The plan sheets in **Appendix A** present a potential edge of pavement and LOD for the preliminary interchange concepts. The edges of pavement shown represent interchange options that could accommodate the widened mainline. During the development of the Interchange Modification Report (IMR), each of the interchange configurations will serve as a starting point for further study and a more in-depth examination of the needs at each location. Operational and geometric improvements were not considered for the cross roads, but would need to be addressed during detailed design. The interchange assumptions were intended for environmental impact analysis and should not be considered specific proposals for design.

Some of the interchanges requiring significant reconstruction were not laid out in full horizontal and vertical detail to develop toe of slope / top of fill lines. These interchanges include:

- I-664 and 25<sup>th</sup> Street interchange
- I-664 and VA 164 interchange
- I-664 and I-264 interchange at Bowers Hill

- VA 164 and VA 164 Connector interchange

To develop an LOD for these interchanges, the following assumptions were used: a full open section with 18 feet of clear zone from the edge of the shoulder; roadside grading at a 3-to-1 slope to tie to the existing ground; and a 30-foot offset to the LOD to accommodate drainage, utilities, stormwater management, and construction easements. To determine an approximate width of roadside grading, it was assumed that the roadways were approximately 15 feet above the surrounding ground. The roadside grading, along with the other roadside design criteria would result in a total distance of approximately 85 feet from the outside edge of shoulders to the LOD.

#### 10.4 OTHER PROPOSED INTERCHANGES

Other proposed interchanges in the Study Area Corridors that are not part of the Build Alternatives and are currently not included in the Long Range Plan may be facilitated by this project. Recommendation of a Preferred Alternative could encourage local leaders to begin the planning process on these interchanges, such as King Street Interchange with I-64 in Hampton and the Air Terminal Interchange with the I-564 Intermodal Connector project. This SEIS does not provide NEPA clearance or traffic analysis for these separate interchange studies.

#### 10.5 LANDSIDE STRUCTURES

Landside structures include all of the bridges in the Study Area Corridors that would be affected due to the Build Alternatives. This would include any bridges along the corridors that would be widened as well as any bridges that would cross over the corridors that would be impacted by the widening. This section does not include any bridges that span the harbor. The improvements to the structures would consist of widening the existing mainline bridges and completely replacing existing overpass bridges to accommodate the widened mainline of each corridor.

Additionally, some of the existing mainline structures are aging and nearing the end of their useful life cycle. Therefore, any mainline structure affected by the Build Alternatives with an FHWA sufficiency rating less than 75 but not yet rated structurally deficient would include rehabilitation to the existing bridge. For structures that are currently classified as structurally deficient, the entire structure would be replaced rather than widened. This repair plan would only apply to the bridges being affected by the widening effort within the Study Area Corridors.

A mainline bridge would be affected when the width of the new proposed bridge is greater than the width documented on the structures' as-built plans. An overpass bridge would be affected, and replaced in full, when the new proposed roadway design interferes with the horizontal clearance of at least one substructure unit of the overpass bridge. Vertical clearance, or any hazards around the overpass bridge, were not investigated to determine if the widened roadway would be feasible under the existing conditions. The horizontal clearance was evaluated to determine if the overpass bridge was affected.

##### 10.5.1 Interstate 64

There are 46 existing bridges within the I-64 Study Area Corridor. Twenty of the existing bridges would be impacted by the proposed improvements. Nineteen of the bridges would be I-64 mainline bridges and one would be an overpass. The existing dimensions and structural details were obtained from as-built plans. The structural deficiency ratings were provided by VDOT in the Hampton Roads District. **Table 10-2** summarizes the existing bridge information for the structures that would be widened as part of the Build Alternatives. **Table 10-3** summarizes the existing bridge information for the structures that cross over I-64 which would be replaced because the I-64 widening improvements would affect their substructure.

**Table 10-2: I-64 Existing Landside Structures Impacted by Proposed Improvements**

Federal Bridge ID	Bridge	No. of Spans	Length	Width	Additional Design Width	Sufficiency Rating	Recommended for Approval
20312	I-64 over US Route 60 and Hampton River	4	250'-11"	113'-10"	7'-1"	96.0	August 1979
20909	I-64 EBL over 13 <sup>th</sup> View Street	3	130'-11"	43'-11"	18'-1"	78.3	May 1966
20911	I-64 WBL over 13 <sup>th</sup> View Street	3	130'-11"	43'-11"	18'-1"	77.2	May 1966
20929	I-64 WBL over 4 <sup>th</sup> View Street	3	184'-0"	44'-0"	20'-1"	85.0	September 1969
20931	I-64 EBL over 4 <sup>th</sup> View Street	3	173'-10"	44'-0"	20'-1"	85.0	September 1969
20823	I-64 WBL over Mason Creek Road	3	179'-1"	44'-0"	20'-1"	82.1	April 1969
20825	I-64 EBL over Mason Creek Road	3	179'-1"	44'-0"	20'-1"	82.8	April 1969
20839	I-64 WBL over 1 <sup>st</sup> View Street	3	168'-11"	44'-0"	19'-1"	75.7	April 1969
20850	I-64 EBL over 1 <sup>st</sup> View Street	3	172'-10"	44'-0"	19'-1"	82.8	April 1969
20869	I-64 WBL over Oastes Creek and Bay Avenue	30	1,675'-5"	43'-4"	19'-3"	82.1	July 1969
20873	I-64 EBL over Oastes Creek and Bay Avenue	36	1,750'-6"	43'-4"	19'-3"	80.6	July 1969
20923	I-64 WBL over Evans Street	3	127'-11"	44'-0"	20'-1"	75.2	March 1972
20925	I-64 EBL over Evans Street	3	127'-11"	44'-0"	20'-1"	81.3	March 1972
20919	I-64 WBL over West Bayview Road	3	141'-1"	44'-0"	21'-1"	88.8	April 1969
20921	I-64 EBL over West Bayview Road	3	137'-1"	44'-0"	21'-1"	88.8	April 1969
20927	I-64 WBL over Mason Creek	15	831'-10"	43'-4"	27'-3"	80.6	July 1969
20928	I-64 EBL over Mason Creek	18	1151'-8"	43'-4"	27'-3"	81.3	April 1969
20915	I-64 WBL over New Gate Road	2	155'-10"	44'-0"	19'-7"	79.5	April 1969
20917	I-64 EBL over New Gate Road	2	155'-10"	44'-0"	19'-7"	79.2	April 1969

**Table 10-3: Structures Crossing Over I-64 Impacted by Proposed Improvements**

Federal Bridge ID	Bridge	No. of Spans	Length	Width	Additional Design Width	Sufficiency Rating	Recommended for Approval
20279	Mallory Street over I-64	4	241'-1"	58'-1"	-	-	July 1979



### 10.5.2 Interstate 664

There are 60 existing bridges within the I-664 Study Area Corridor. Thirty-six of the existing bridges would be impacted by the proposed improvements: 28 of them would be I-664 mainline bridges and eight would be overpasses. The existing dimensions and structural details were obtained from as-built plans. The structural deficiency ratings were provided by VDOT in the Hampton Roads District. Four new bridges are included in the Build Alternatives in the I-664 Study Area Corridor. One mainline bridge, being affected by the widening improvements, would be repaired in addition to being widened. **Table 10-4** summarizes the existing bridge information for the structures that would be widened or would be demolished as part of these improvements. **Table 10-5** summarizes the existing bridge information for the structures that cross over I-664 which would be replaced because the I-664 widening improvements affects their substructure. **Table 10-6** summarizes new bridge information for the structures that would be constructed as part of the proposed improvements.

**Table 10-4: I-664 Existing Landside Structures Impacted by Proposed Improvements**

Federal Bridge ID	Bridge	No. of Spans	Length	Width	Additional Design Width	Sufficiency Rating	Recommended for Approval
20744	I-664 Ramp J over 36 <sup>th</sup> Street and CSX Railroad	5	655'-8"	39'-8"	DEMO Alt C DEMO Alt D	93.9	1987
20391	I-664 over VA 415 (Queen Street)	4	166'-0"	132'-6"	21'-6" Alt C 21'-6" Alt D	79	1982
20393	I-664 over Aberdeen Road	3	244'-1"	119'-9"	58'-3" Alt C 34'-3" Alt D	97	1983
20395	I-664 over CSX Railway Spur	3	202'-1"	143'-8"	58'-4" Alt C 34'-4" Alt D	82.6	1983
20736	I-664 over Chestnut Avenue	1	145'-11"	121'-4"	56'-8" Alt C 32'-8" Alt D	83.3	1983
20738	I-664 over Roanoke Avenue	1	129'-11"	121'-4"	56'-8" Alt C 32'-8" Alt D	76	1985
20740	I-664 over 39 <sup>th</sup> Street and VA 351	15	1,103'-9"	120'-4"	57'-8" Alt C 45'-8" Alt D	83	1987
20742	I-664 over CSX Railroad and Jefferson Avenue	5	439'-10"	108'-7"	35'-8" Alt C 23'-8" Alt D	89.6	1987
20748	I-664 over CSX Transport and Jefferson Avenue	7	616'-11"	37'-9"	- 4'-3" Alt D	94.9	1987
20750	I-664 over Terminal Avenue	41	6,142'-6"	90'-6"	111'-6" Alt C 89'-6" Alt D	73	1990
20757	I-664 over Harbor Access Road	4	461'-10"	44'-3"	5'-9" Alt C 5'-9" Alt D	96.7	1990
20754	I-664 over Terminal Avenue	7	747'-10"	33'-9"	DEMO Alt C DEMO Alt D	97.9	1990
20761	I-664 Ramp D over Terminal Avenue	4	501'-10"	33'-9"	9'-3" Alt C DEMO Alt D	95.6	1990
23091	I-664 NBL over VA 164	2	224'-1"	55'-9"	22'-3"	98	1991
23092	I-664 SBL over VA 164	2	224'-1"	55'-9"	23'-1"	98	1991

**Table 10-4: I-664 Existing Landside Structures Impacted by Proposed Improvements**

Federal Bridge ID	Bridge	No. of Spans	Length	Width	Additional Design Width	Sufficiency Rating	Recommended for Approval
23095	I-664 NBL over US Route 17 and VA 164	3	244'-1"	43'-11"	22'-1"	97	1991
23096	I-664 SBL over US Route 17 and VA 164	3	243'-1"	55'-9"	23'-4"	97	1991
23099	I-664 NBL over Commonwealth Railroad	3	396'-10"	55'-9"	23'-4"	98	1991
23109	I-664 NBL over N&W Railroad	3	185'-0"	45'-3"	22'-9"	94.3	1991
23110	I-664 SBL over N&W Railroad	2	284'-1"	57'-5"	22'-7"	87.1	1991
23105	I-664 NBL over Bailey Creek	3	481'-10"	57'-5"	22'-7"	93.9	1991
23106	I-664 SBL over Bailey Creek	3	481'-10"	57'-5"	22'-7"	87.4	1991
23102	I-664 NBL over Goose Creek	3	481'-10"	57'-5"	22'-7"	90.1	1991
23103	I-664 SBL over Goose Creek	3	481'-10"	57'-5"	22'-7"	87.4	1991
23014	I-664 NBL over US Route 58 and US Route 13	2	379'-10"	57'-5"	10'-7"	98	1991
23015	I-664 SBL over US Route 58 and US Route 13	2	359'-10"	57'-5"	22'-7"	97	1991
21911	I-664 NBL over US Route 13 and US Route 460	6	681'-11"	80'-1"	2'-0"	86.5	1983
21913	I-664 SBL over US Route 13 and US Route 460	6	701'-11"	67'-11"	24'-1"	83.4	1983

**Table 10-5: Structures Crossing Over I-664 Impacted by Proposed Improvements**

Bridge ID	Bridge	No. Spans	Length	Width	Additional Design Width	Sufficiency Rating	Recommended for Approval
20647	34th St EBL over I-664	12	1,194'-7"	59'-5"	-	-	February 1984
20649	34th St WBL over I-664	13	1,197'-10"	59'-5"	-	-	February 1984
20663	28th St over I-664	7	1016'-10"	68'-11"	-	-	July 1977
29306	Ramp D from I-664 SB over I-664	4	415'-11"	33'-2"	-	97	1988
29307	26th Street Ramp over I-664	7	592'-8"	43'-0"	-	77.5	1988
29405	Ramp E over I-664	4	348'-0"	33'-2"	-	100	1988
20651	26th Street over I-664	9	1,101'-9"	39'-1"	-	-	April 1984
20653	23rd and 25th Street over I-664	11	1,103'-9"	39'-8"	-	-	April 1984

**Table 10-6: Proposed I-664 Landside Structures**

Bridge ID <sup>1</sup>	Bridge	Length	Width
(19)	I-664 Ramp over US Route 17	240'-0"	45'-9"
(22)	I-664 Ramp over VA 164	245'-0"	32'-0"
(24)	I-664 Ramp over I-664	165'-0"	32'-0"
(26)	34 <sup>th</sup> Street Ramp onto I-664	1,200'-0"	42'-0" Alt C 36'-0" Alt D

<sup>1</sup> VDOT Bridge ID number not yet assigned

**10.5.3 Interstate 564 Connector**

There are 10 existing bridges within the I-564 Study Area Corridor. However, none of the existing bridges would be impacted by the proposed improvements. Eight new bridges would be included in the proposed design. **Table 10-7** summarizes the new bridge information for the proposed structures.

**Table 10-7: Proposed I-564 Connector Structures**

Bridge ID <sup>1</sup>	Bridge	Length	Width
(7)	I-564 Connector Mainline Bridge	273'-3"	96'-0"
(8)	I-564 Connector Mainline Bridge	125'-6"	48'-0"
(9)	I-564 Connector Mainline Bridge	125'-6"	48'-0"
(10)	I-564 Connector Mainline Bridge	337'-4"	142'-0"
(11)	I-564 Connector Mainline Bridge	180'-9"	150'-0"
(12)	I-564 Connector Mainline Bridge	96'-9"	40'-0"
(13)	I-564 Connector Mainline Bridge	97'-4"	28'-0"
(14)	I-564 Connector Mainline Bridge	639'-3"	62'-0"

<sup>1</sup> VDOT Bridge ID number not yet assigned

**10.5.4 VA 164 Connector**

There are 11 existing bridges within the VA 164 Study Area Corridor. Eight of the existing bridges would be impacted by the proposed improvements. Five bridges are VA 164 mainline bridges. The existing dimensions and structural details were obtained from as-built plans. The structural deficiency ratings were provided by VDOT in the Hampton Roads District. Thirteen new bridges would be proposed in this Study Area Corridor as part of the Build Alternatives. **Table 10-8** summarizes the existing bridge information for the structures that would be widened or would be demolished as part of these improvements. **Table 10-9** summarizes the existing bridge information for the structures that cross over VA 164 that would be replaced due to the proposed VA 164 widening. **Table 10-10** summarizes new bridge information for the structures that would be created as part of these improvements.

**Table 10-8: VA-164 Existing Landside Structures Impacted by Proposed Improvements**

Federal Bridge ID	Bridge	No. of Spans	Length	Width	Additional Design Width	Sufficiency Rating	Recommended for Approval
21206	I-164 WBL over Rail Road Spur	2	336'-10"	41'-8"	10'-4"	83	1991
21208	I-164 EBL over Rail Road Spur	2	331'-11"	41'-8"	10'-4"	94	1991
28241	I-164 WBL over APM Blvd	1	97'-1"	45'-3"	56'-9"	96.9	2006
28239	I-164 EBL over APM Blvd	1	97'-1"	45'-3"	0'-0"	98	2006
(25) <sup>1</sup>	VA 164 Ramp EB over VA 164	2	225'-0"	32'-0"	DEMO	-	-

<sup>1</sup> VDOT Bridge ID number not yet assigned

**Table 10-9: Structures Crossing over VA 164 Impacted by Proposed Improvements**

Federal Bridge ID	Bridge	No. of Spans	Length	Width	Additional Design Width	Sufficiency Rating	Recommended for Approval
22080	College Drive over I-164	3	293'-10"	97'-9"	-	-	May 1988
21195	Towne Point Road over I-164	5	268'-0"	86'-7"	-	-	June 1986
21197	Cedar Lane over I-164	5	319'-10"	98'-5"	-	-	March 1986

**Table 10-10: Proposed VA 164 Landside Structures**

Bridge ID <sup>1</sup>	Bridge	Length	Width
(1)	VA 164 and VA 164 Connector Interchange Bridge	661'-6"	32'-0"
(2)	VA 164 and VA 164 Connector Interchange Bridge	633'-6"	32'-0"
(3)	VA 164 and VA 164 Connector Interchange Bridge	247'-3"	40'-0"
(4)	VA 164 and VA 164 Connector Interchange Bridge	953'-0"	32'-0"
(5)	VA 164 and VA 164 Connector Interchange Bridge	157'-7"	40'-0"
(6)	VA 164 and VA 164 Connector Interchange Bridge	117'-3"	32'-0"
(15)	VA 164 and VA 164 Connector Interchange Bridge	1,400'-0"	122'-0"
(16)	VA 164 and VA 164 Connector Interchange Bridge	176'-0"	124'-0"
(17)	VA 164 and VA 164 Connector Interchange Bridge	310'-0"	52'-0"
(18)	VA 164 and VA 164 Connector Interchange Bridge	297'-0"	52'-0"
(20)	VA 164 Ramp over VA 164	1,020'-0"	32'-0"
(21)	VA 164 Ramp over VA 164	165'-0"	32'-0"
(23)	VA 164 Flyover over I-664	895'-0"	32'-0"

<sup>1</sup> VDOT Bridge ID number not yet assigned

## 10.6 APPROACH BRIDGES TO TUNNELS

### Interstate 64

The two sets of existing HRBT approach bridges currently carry two lanes per direction. In Alternatives A, B, and D, the eastbound I-64 bridge would be modified to carry two westbound lanes. A new bridge would be constructed to the west of the existing bridges to carry the eastbound lanes. It would include three 12-foot travel lanes and 14-foot shoulders. Construction of the new approach bridge would require dredging of a ten-foot deep channel, with four-to-one side slopes, extending both below and 150 feet outside the footprint on one side of the proposed structure. **Figure 10-2** shows the approach bridge typical sections.

Major rehabilitation is being proposed for the approach bridges. Rehabilitation would retain the existing 12-foot lanes, four-foot left shoulders, and 10-foot right shoulders. The existing westbound spans would be restriped to include one lane. Rehabilitation would also be included in the No-Build Alternative.

Major rehabilitation would consist of superstructure work only and would require a ten-foot deep, 150-foot wide channel with four-to-one side slopes, to be dredged adjacent to the outer edge of the bridges to allow adequate width for construction barges because the water is less than ten feet deep. Rehabilitation would include the removal and replacement of the existing superstructure, crack sealing, repair, jacketing existing piling, replacement of piling, and the replacement of parapets. The rehabilitation would not address the existing roadway geometric deficiency of narrow shoulders; therefore, design exceptions may be necessary. In addition, the bridges would not be raised from their existing elevation (10.35 feet relative to North American Vertical Datum [NAVD] to bottom of girder) to meet the clearance specifications in the *Guide Specifications for Bridges Vulnerable to Coastal Storms* (AASHTO, 2009) because work would only take place on the superstructure.

### Interstate 664

The two existing approach bridges currently carry two lanes per direction. In Alternatives C and D, the eastbound I-664 bridge would be modified to carry two westbound lanes.

In Alternative C, two new bridges would be constructed to the west (upstream) of the existing bridges. The bridge adjacent to the existing bridges would carry two barrier-separated 16-foot transit lanes and 8-foot shoulders. The second bridge would include four 12-foot eastbound travel lanes and 14-foot shoulders.

In Alternative D, one new bridge would be constructed to the west (upstream) of the existing bridges and would include four 12-foot eastbound travel lanes and 14-foot shoulders. **Figure 10-3** shows the Alternatives C and D approach bridge typical sections.

Construction of the new approach bridges in each Alternative would require dredging of a ten-foot deep channel, with four-to-one side slopes, extending both below and 150 feet outside the footprint on one side of the proposed structures.

The same major rehabilitation improvement option would be considered for the I-664 approach bridges as the I-64 approach bridges. Similarly, with the rehabilitation option, the bridges would not be raised from their existing elevation (17.55 feet relative to North American Vertical Datum [NAVD] to bottom of girder) to meet the clearance specifications in the *Guide Specifications for Bridges Vulnerable to Coastal Storms* (AASHTO, 2009) because work would only take place on the superstructure.



Figure 10-2: I-64 Approach Bridges to Tunnels Typical Section

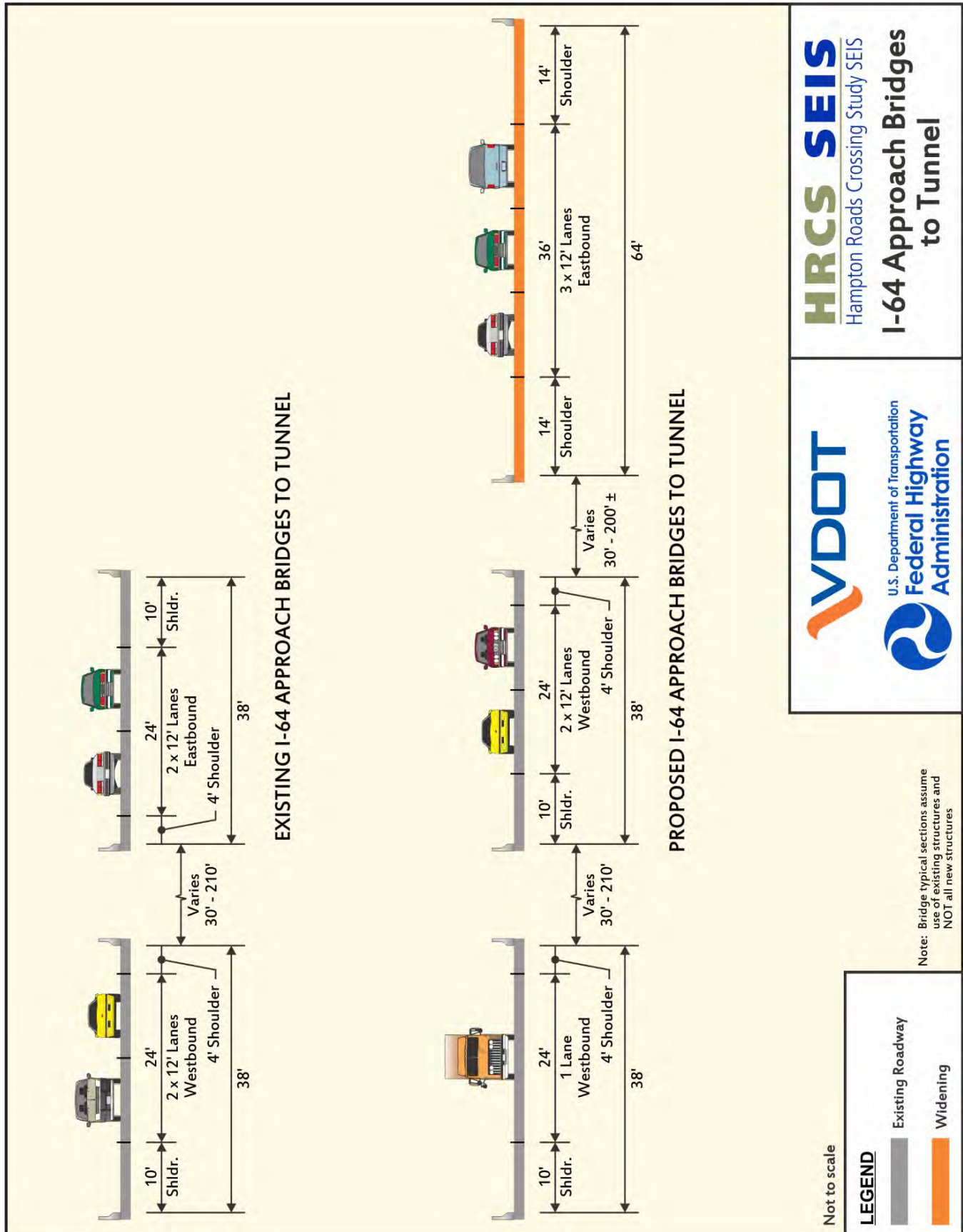
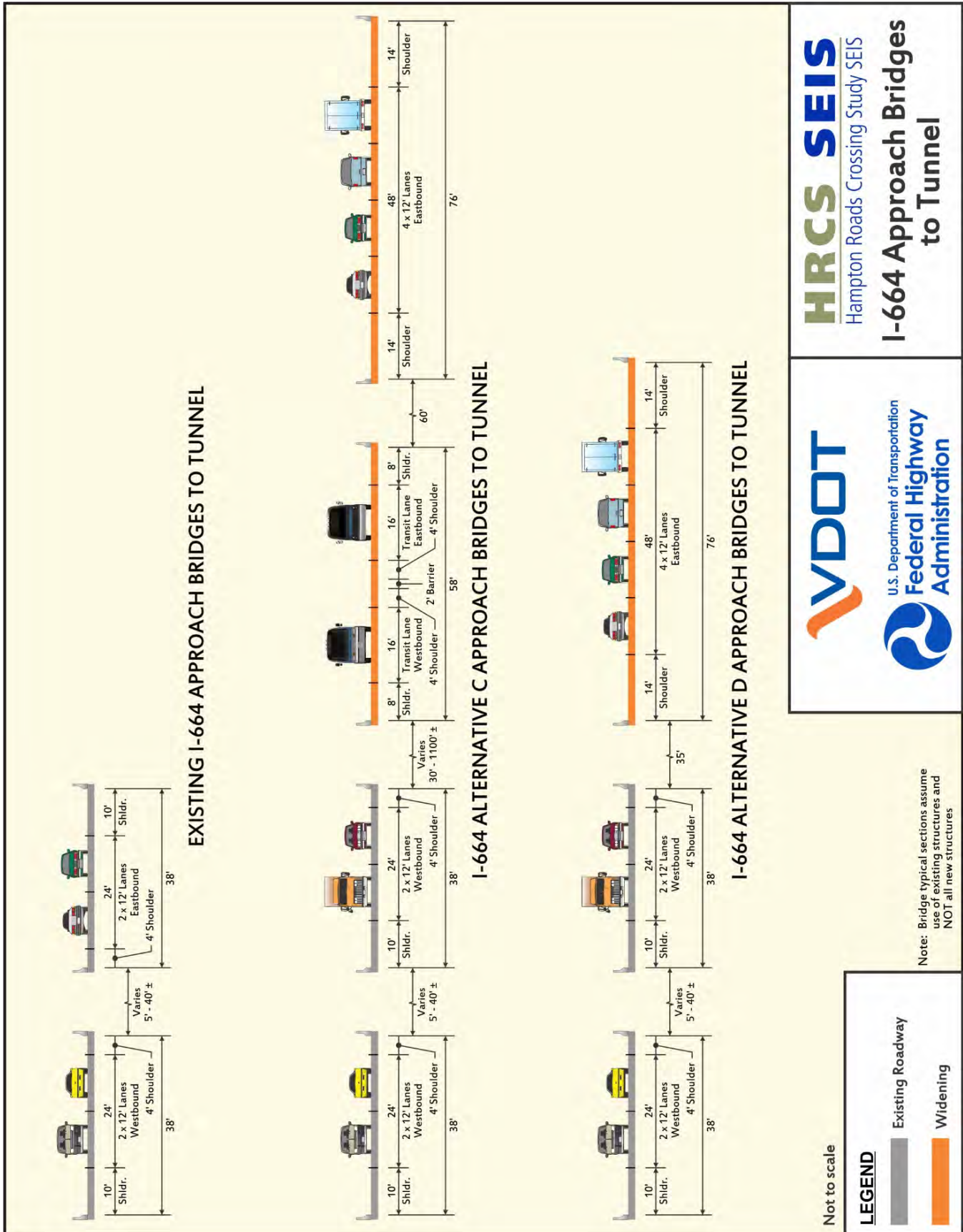

Figure 10-3: I-664 Approach Bridge to Tunnels Typical Section



## 10.8 TUNNELS

### 10.8.1 Existing Tunnels

#### Interstate 64

In Alternatives A, B, and D, the eastbound HRBT tunnel would be modified to carry two westbound lanes and both tunnels would be rehabilitated and upgraded. Rehabilitation would include replacement of wall tiles, replacement of structural slab and wearing surface, replacement/upgrade of utilities and other maintenance-related items.

Additional information on the existing tunnels have been designated Sensitive Security Information that is controlled under 49 CFR parts 15 and 1520. No part of that information may be disclosed to persons without a “need-to-know”, as defined in 49 CFR parts 15 and 1520, except with the written permission of the Administrator of the Transportation Security Administration or the Secretary of Transportation. Unauthorized release may result in civil penalty or other action. For US government agencies, public disclosure is governed by 5 U.S.C. 552 and 49 CFR parts 15 and 1520.

The existing 13 foot 6-inch vertical clearance for the westbound HRBT tunnel is problematic for some trucks. Options to increase the vertical clearance in the westbound tunnel to allow all standard height trucks to cross the HRBT and eliminate the need to remove overheight vehicles from the traffic stream have been explored. However, the logistics of increasing the vertical clearance are challenging and more detailed design will be necessary to determine if these options are feasible.

If it is determined that increasing the vertical clearance is not a viable option at the westbound tunnel, an additional option would be considered and has been included in the footprint of Build Alternatives. Overheight trucks that are not deterred by previous signage or detection systems would be routed around the south portal island to enter I-64 eastbound, and be redirected to the MMMBT. In this way, only one westbound travel lane would need to be stopped to remove the overheight truck from the roadway. Eastbound traffic would not need to be stopped because an acceleration lane would be added to the eastbound approach bridge departing the tunnel. This would only be required on the westbound tunnels, because the new eastbound tunnels would be constructed to current design standards.

The turning radius on the south island tunnel truck turnaround is based on a WB-67 at 15 mph. The acceleration lane for the truck turnaround entrance ramp on eastbound I-64 would be approximately 1,620 feet long. This is based on 2011 AASHTO standards for vehicles from a stopped condition to 70 mph. A 300-foot taper would be used at the end of the acceleration lane.

#### Interstate 664

In Alternatives C and D, the southbound MMMBT tunnel would be modified to carry two northbound lanes and both tunnels would be rehabilitated and upgraded.

The safety systems in the existing tunnels, including fire detection, protection, and means of egress, would be upgraded to better comply with NFPA 502 standards to the maximum extent practicable.

### 10.8.2 New Tunnels

Much of the information on the proposed design of the tunnels has been designated Sensitive Security Information that is controlled under 49 CFR parts 15 and 1520. No part of that information may be disclosed to persons without a “need-to-know”, as defined in 49 CFR parts 15 and 1520, except with the written permission of the Administrator of the Transportation Security Administration or the Secretary

of Transportation. Unauthorized release may result in civil penalty or other action. For US government agencies, public disclosure is governed by 5 U.S.C. 552 and 49 CFR parts 15 and 1520.

#### **Interstate 64**

In Alternatives A, B, and D, a new tunnel carrying the eastbound lanes would be constructed west of the existing tunnel. The proposed tunnel portals would not be located immediately adjacent to the existing tunnel portals due to the profile and the depth of the new tunnel; however, the new portals would be close enough to the existing portals to allow the existing islands to be expanded by approximately 75 to 100 feet to receive the new tunnel and approach bridges without creating new islands.

#### **Interstate 664**

In Alternatives C and D, new tunnels carrying the eastbound lanes would be constructed west of the existing tunnel. In Alternative D, one new tunnel is proposed. It would include four southbound general purpose travel lanes. In Alternative C, two new tunnels are proposed. One tunnel would include four southbound general purpose travel lanes, and the other tunnel would include two transit lanes, one in each direction in two compartments.

The proposed tunnel portals would not be located immediately adjacent to the existing tunnel portals because the alignment of southbound I-664 diverges from northbound I-664 in Newport News.

#### **Interstate 564**

In Alternatives B, C, and D, new tunnels would be constructed. In Alternatives B and D, one new tunnel is proposed. It would include two eastbound general purpose travel lanes in one compartment and two westbound general purpose travel lanes in one compartment. In Alternative C, two new tunnels are proposed. One tunnel would include two eastbound general purpose travel lanes in one compartment and one eastbound transit lane in one compartment. The other tunnel would include two westbound general purpose travel lanes in one compartment and one westbound transit lane in one compartment.

## 10.9 TRUCK WEIGH AND INSPECTION STATIONS

### 10.9.1 Interstate 64

The existing truck weigh and inspection station located on westbound I-64 on the Willoughby Spit would remain in place. It would not be impacted by the proposed improvements in the I-64 Study Area Corridor.

On eastbound I-64, the existing truck weigh and inspection station would be impacted by the proposed widening. The facility could be reconstructed in place or just to the south on Hampton University property that is impacted by the proposed widening.

### 10.9.2 Interstate 664

The existing truck weigh and inspection station location on northbound I-664 south of the MMMBT would remain in place. It would not be impacted by the proposed improvements in the I-664 Study Area Corridor.

On southbound I-664, the existing truck weigh and inspection station would be impacted by the proposed widening and would be reconstructed near the same location to accommodate the wider footprint.

### 10.9.3 Interstate 564

On eastbound I-564, the proposed truck weigh and inspection station would be located west of the tunnel portal, on the approach bridge. On westbound I-564, the proposed truck weigh and inspection station would be located in the median of I-564 just east of Hampton Boulevard.

## 11. PRELIMINARY COST ESTIMATES

Preliminary Cost estimates were prepared for each alignment segment using VDOT’s Project Cost Estimating System (PCES) Program. Specific costs for non-standard elements, which include rehabilitation of approach bridges and tunnel as well as dredging costs, were based on input from VDOT Structure and Bridge staff. The Cost Estimate Methodology is included in **Appendix B**. Preliminary Cost estimates are in 2016 dollars and include a 40 percent contingency. Detailed Preliminary Cost Estimates are included in **Appendix C** for each alignment segment and for each Alternative and are summarized in **Table 11-1**.

**Table 11-1: Preliminary Construction Cost Estimates**

Cost Estimate Elements	Alternative A	Alternative B	Alternative C	Alternative D
Construction Cost	\$2.9B	\$5.8B	\$11.1B	\$10.6B
Preliminary Engineering	\$237.6M	\$487.4M	\$857.9M	\$809.3M
Right-of-Way and Utilities	\$68.8M	\$224.9M	\$466.3M	\$466.0M
<b>Total Cost</b>	<b>\$3.2B</b>	<b>\$6.6B</b>	<b>\$12.5B</b>	<b>\$11.8B</b>

**APPENDIX A:**  
**ALTERNATIVES MAPPING**

This appendix contains the plan sheets for the Build Alternatives. A key map is provided for each Build Alternative that shows the plan sheet figure numbers that comprise each alternative. Following the key maps, the plan sheets are provided in numerical order. Where the plan sheets vary among alternatives, for example Figure 10, the Build Alternative letter is included in the legend of that figure, i.e., Figure 10C and Figure 10D are both provided.

The plan sheet Figure numbers that comprise each Build Alternative are summarized below:

Alternative A: 2, 3, 4, 5, 6, 7, 8, 9

Alternative B: 2, 3, 4, 5, 6, 7, 8, 9, 23, 24, 25, 26, 27B, 29B, 30B, 31B

Alternative C: 10C, 11C, 12C, 13C, 14C, 15C, 16, 17, 18, 19, 20, 21, 22, 25, 26, 27C, 28C, 29C, 30C, 31C, 32C

Alternative D: 2, 3, 4, 5, 6, 7, 8, 9, 10D, 11D, 12D, 13D, 14D, 15D, 16, 17, 18, 19, 20, 21, 22, 23, 24, 25, 26, 27D, 28D, 29D, 30D, 31D



**LEGEND**

	PROPOSED ROADWAY IMPROVEMENTS		HISTORIC PROPERTIES
	PROPOSED STRUCTURES		PARKS
	PROPOSED LIMIT OF DISTURBANCE		PARCEL BOUNDARY
	POTENTIAL DISPLACEMENTS		PROPOSED NOISE BARRIERS
	WETLANDS / WATERS		IMPACTED NOISE RECEPTORS
	FEDERAL PROPERTIES		ALTERNATIVES A AND B
			ALTERNATIVE C
			ALTERNATIVE D

SCALE IN FEET: 0 300 600 1200

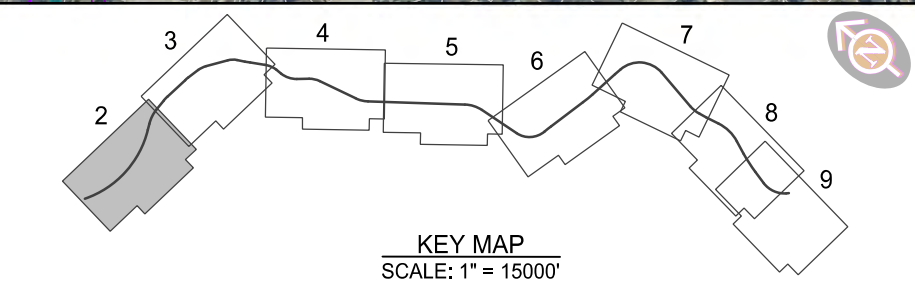

**Note:**  
The information shown is for the purpose of determining cost estimates and environmental impacts and is subject to change during the final design phase. Any reliance upon these plans is made with full understanding of its draft status. Environmental impacts described in the SEIS are based on proposed limits of disturbance.

Aerial Imagery Copyright 2013 Commonwealth of Virginia

**HRCs SEIS**  
Hampton Roads Crossing Study SEIS

**I-64**

**VDOT**  
Virginia Department of Transportation

July 2016

U.S. Department of Transportation  
**Federal Highway Administration**

Figure 2





**LEGEND**

	PROPOSED ROADWAY IMPROVEMENTS		HISTORIC PROPERTIES
	PROPOSED STRUCTURES		PARKS
	PROPOSED LIMIT OF DISTURBANCE		PARCEL BOUNDARY
	POTENTIAL DISPLACEMENTS		PROPOSED NOISE BARRIERS
	WETLANDS / WATERS		IMPACTED NOISE RECEPTORS
	FEDERAL PROPERTIES		ALTERNATIVES A AND B
			ALTERNATIVE C
			ALTERNATIVE D

SCALE IN FEET: 0 300 600 1200

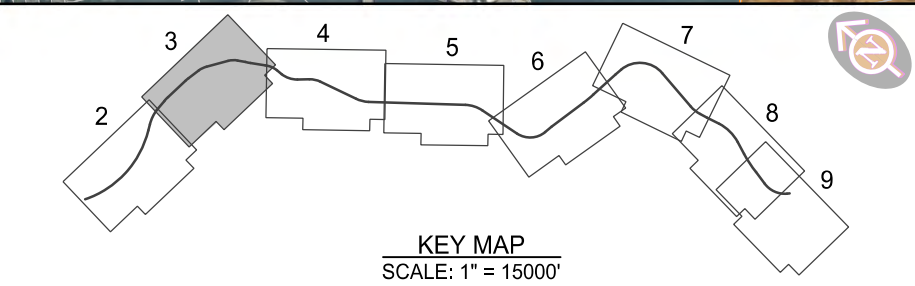

**Note:**  
The information shown is for the purpose of determining cost estimates and environmental impacts and is subject to change during the final design phase. Any reliance upon these plans is made with full understanding of its draft status. Environmental impacts described in the SEIS are based on proposed limits of disturbance.

Aerial Imagery Copyright 2013 Commonwealth of Virginia

**HRCs SEIS**  
Hampton Roads Crossing Study SEIS

**I-64**

**VDOT**  
Virginia Department of Transportation

U.S. Department of Transportation  
**Federal Highway Administration**

July 2016  
Figure 3



**LEGEND**

	PROPOSED ROADWAY IMPROVEMENTS		HISTORIC PROPERTIES
	PROPOSED STRUCTURES		PARKS
	PROPOSED LIMIT OF DISTURBANCE		PARCEL BOUNDARY
	POTENTIAL DISPLACEMENTS		PROPOSED NOISE BARRIERS
	WETLANDS / WATERS		IMPACTED NOISE RECEPTORS
	FEDERAL PROPERTIES		ALTERNATIVES A AND B
			ALTERNATIVE C
			ALTERNATIVE D

SCALE IN FEET: 0 300 600 1200

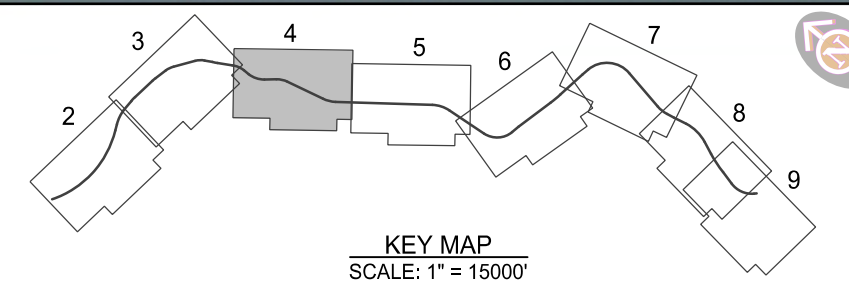

**Note:**  
The information shown is for the purpose of determining cost estimates and environmental impacts and is subject to change during the final design phase. Any reliance upon these plans is made with full understanding of its draft status. Environmental impacts described in the SEIS are based on proposed limits of disturbance.

Aerial Imagery Copyright 2013 Commonwealth of Virginia

**HRCS SEIS**  
Hampton Roads Crossing Study SEIS

I-64

**VDOT** July 2016

U.S. Department of Transportation  
**Federal Highway Administration** Figure 4

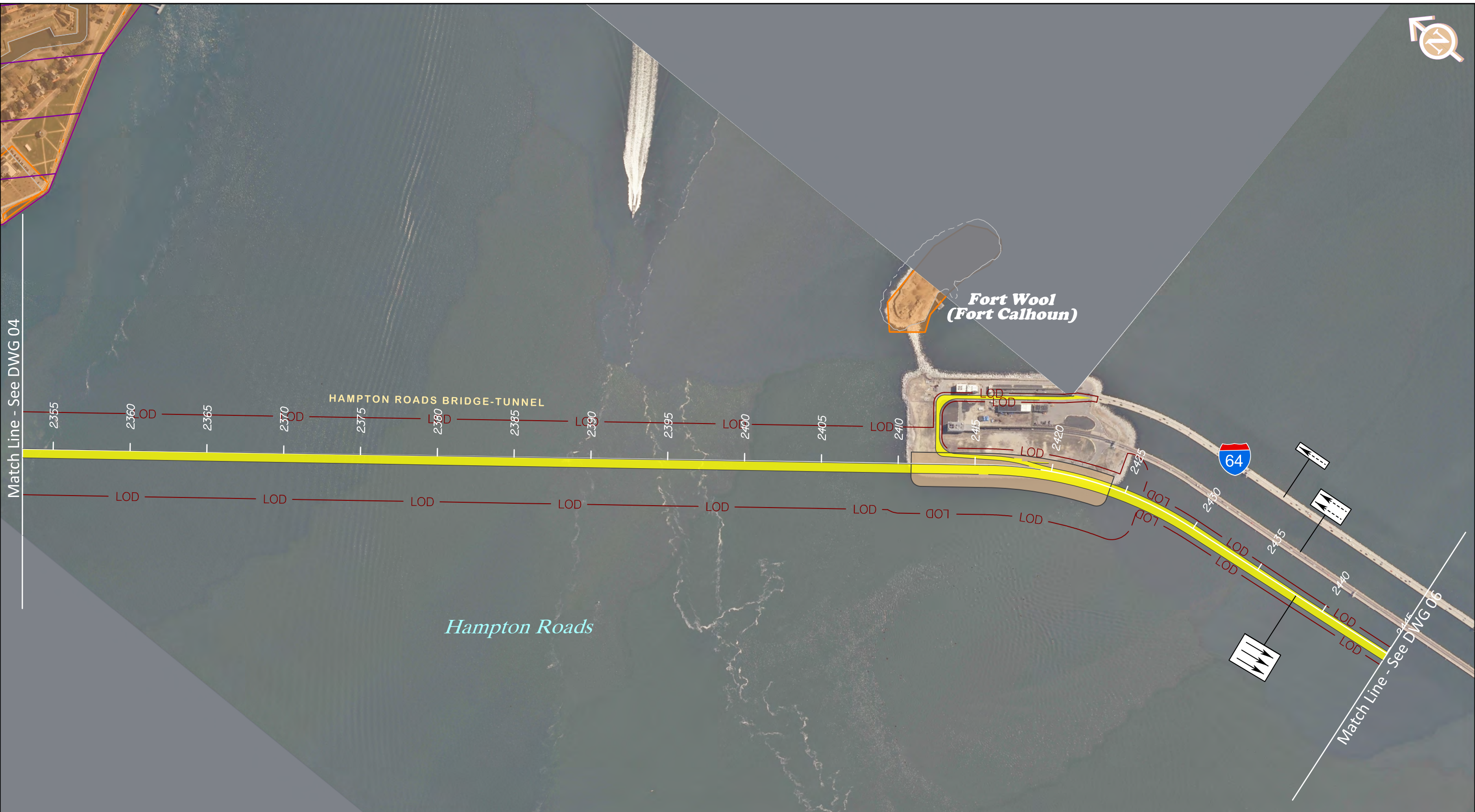

**LEGEND**

	PROPOSED ROADWAY IMPROVEMENTS		HISTORIC PROPERTIES
	PROPOSED STRUCTURES		PARKS
	PROPOSED LIMIT OF DISTURBANCE		PARCEL BOUNDARY
	POTENTIAL DISPLACEMENTS		PROPOSED NOISE BARRIERS
	WETLANDS / WATERS		IMPACTED NOISE RECEPTORS
	FEDERAL PROPERTIES		ALTERNATIVES A AND B
			ALTERNATIVE C
			ALTERNATIVE D

SCALE IN FEET: 0 300 600 1200

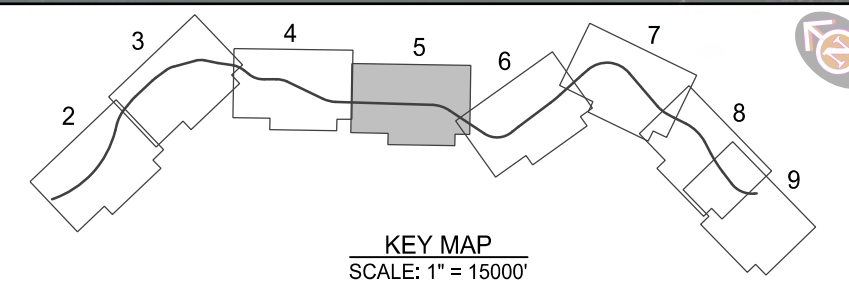

**Note:**  
The information shown is for the purpose of determining cost estimates and environmental impacts and is subject to change during the final design phase. Any reliance upon these plans is made with full understanding of its draft status. Environmental impacts described in the SEIS are based on proposed limits of disturbance.

Aerial Imagery Copyright 2013 Commonwealth of Virginia

**HRCs SEIS**  
Hampton Roads Crossing Study SEIS

**I-64**

**VDOT**  
Virginia Department of Transportation

U.S. Department of Transportation  
**Federal Highway Administration**

July 2016  
Figure 5



**LEGEND**

	PROPOSED ROADWAY IMPROVEMENTS		HISTORIC PROPERTIES
	PROPOSED STRUCTURES		PARKS
	PROPOSED LIMIT OF DISTURBANCE		PARCEL BOUNDARY
	POTENTIAL DISPLACEMENTS		PROPOSED NOISE BARRIERS
	WETLANDS / WATERS		IMPACTED NOISE RECEPTORS
	FEDERAL PROPERTIES		ALTERNATIVES A AND B
			ALTERNATIVE C
			ALTERNATIVE D

SCALE IN FEET: 0 300 600 1200

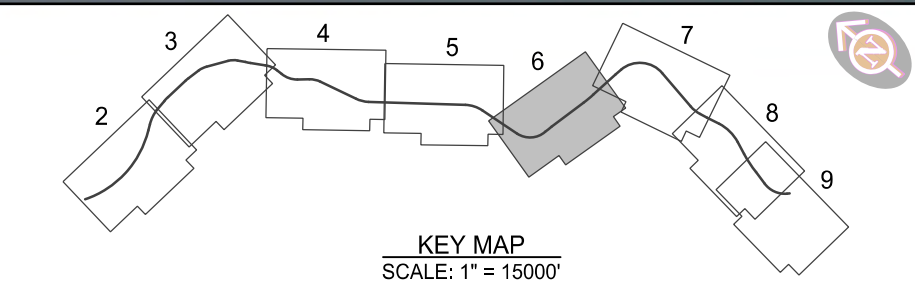

**Note:**  
The information shown is for the purpose of determining cost estimates and environmental impacts and is subject to change during the final design phase. Any reliance upon these plans is made with full understanding of its draft status. Environmental impacts described in the SEIS are based on proposed limits of disturbance.

Aerial Imagery Copyright 2013 Commonwealth of Virginia

**HRCs SEIS**  
Hampton Roads Crossing Study SEIS

**I-64**

**VDOT** July 2016

U.S. Department of Transportation  
**Federal Highway Administration** Figure 6



**LEGEND**

	PROPOSED ROADWAY IMPROVEMENTS		HISTORIC PROPERTIES
	PROPOSED STRUCTURES		PARKS
	PROPOSED LIMIT OF DISTURBANCE		PARCEL BOUNDARY
	POTENTIAL DISPLACEMENTS		PROPOSED NOISE BARRIERS
	WETLANDS / WATERS		IMPACTED NOISE RECEPTORS
	FEDERAL PROPERTIES		ALTERNATIVES A AND B
			ALTERNATIVE C
			ALTERNATIVE D

SCALE IN FEET: 0 300 600 1200

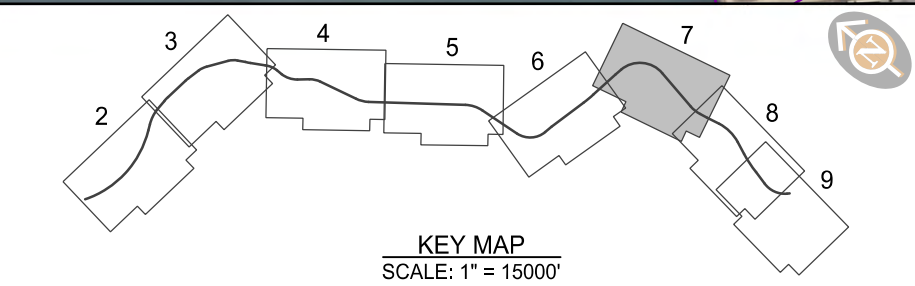

**Note:**  
The information shown is for the purpose of determining cost estimates and environmental impacts and is subject to change during the final design phase. Any reliance upon these plans is made with full understanding of its draft status. Environmental impacts described in the SEIS are based on proposed limits of disturbance.

Aerial Imagery Copyright 2013 Commonwealth of Virginia

**HRCs SEIS**  
Hampton Roads Crossing Study SEIS

**I-64**

**VDOT**  
Virginia Department of Transportation

July 2016

U.S. Department of Transportation  
**Federal Highway Administration**

Figure 7

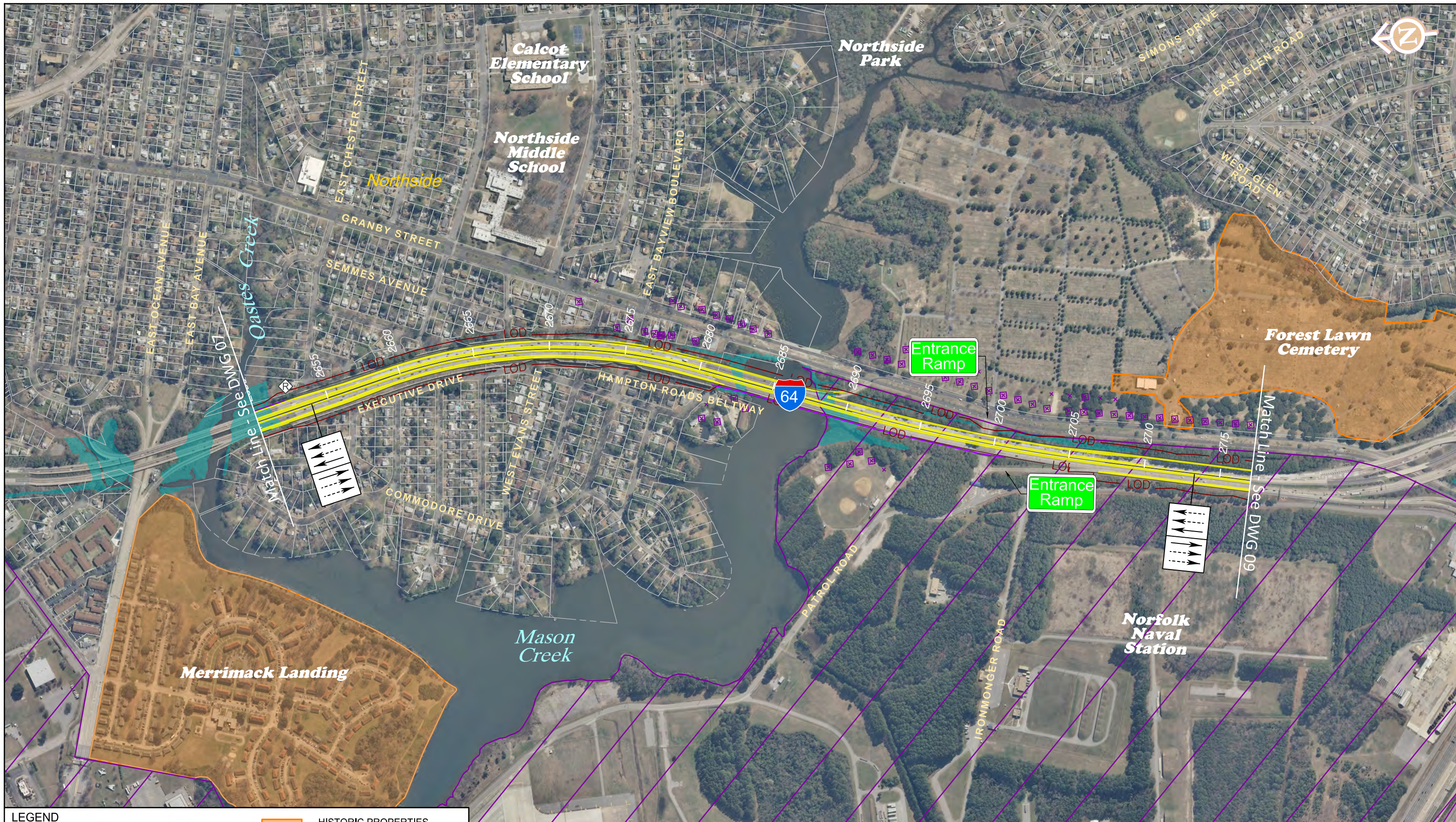

**LEGEND**

	PROPOSED ROADWAY IMPROVEMENTS		HISTORIC PROPERTIES
	PROPOSED STRUCTURES		PARKS
	PROPOSED LIMIT OF DISTURBANCE		PARCEL BOUNDARY
	POTENTIAL DISPLACEMENTS		PROPOSED NOISE BARRIERS
	WETLANDS / WATERS		IMPACTED NOISE RECEPTORS
	FEDERAL PROPERTIES		ALTERNATIVES A AND B
			ALTERNATIVE C
			ALTERNATIVE D

SCALE IN FEET: 0 300 600 1200

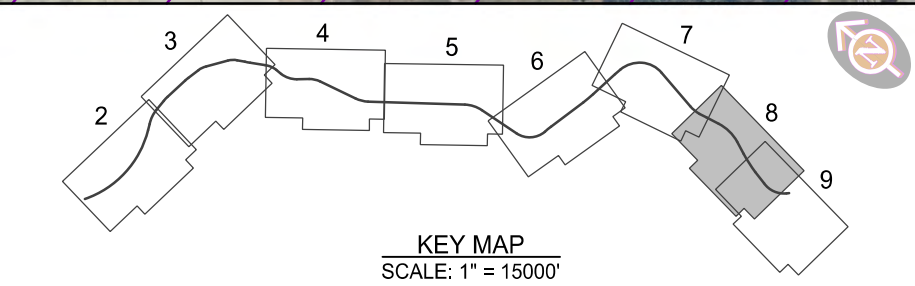

Note:  
The information shown is for the purpose of determining cost estimates and environmental impacts and is subject to change during the final design phase. Any reliance upon these plans is made with full understanding of its draft status. Environmental impacts described in the SEIS are based on proposed limits of disturbance.

Aerial Imagery Copyright 2013 Commonwealth of Virginia

**HRCs SEIS**  
Hampton Roads Crossing Study SEIS

**I-64**

**VDOT**  
Virginia Department of Transportation

July 2016

U.S. Department of Transportation  
**Federal Highway Administration**

Figure 8



**LEGEND**

	PROPOSED ROADWAY IMPROVEMENTS		HISTORIC PROPERTIES
	PROPOSED STRUCTURES		PARKS
	PROPOSED LIMIT OF DISTURBANCE		PARCEL BOUNDARY
	POTENTIAL DISPLACEMENTS		PROPOSED NOISE BARRIERS
	WETLANDS / WATERS		IMPACTED NOISE RECEPTORS
	FEDERAL PROPERTIES		ALTERNATIVES A AND B
			ALTERNATIVE C
			ALTERNATIVE D

SCALE IN FEET: 0 300 600 1200

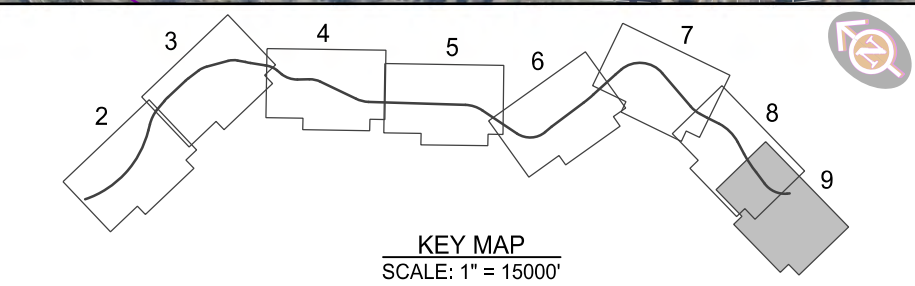

**Note:**  
The information shown is for the purpose of determining cost estimates and environmental impacts and is subject to change during the final design phase. Any reliance upon these plans is made with full understanding of its draft status. Environmental impacts described in the SEIS are based on proposed limits of disturbance.

Aerial Imagery Copyright 2013 Commonwealth of Virginia

**HRCS SEIS**  
Hampton Roads Crossing Study SEIS

**I-64**

**VDOT** July 2016

U.S. Department of Transportation  
**Federal Highway Administration** Figure 9



**LEGEND**

	PROPOSED ROADWAY IMPROVEMENTS		HISTORIC PROPERTIES
	PROPOSED STRUCTURES		PARKS
	PROPOSED LIMIT OF DISTURBANCE		PARCEL BOUNDARY
	POTENTIAL DISPLACEMENTS		PROPOSED NOISE BARRIERS
	WETLANDS / WATERS		IMPACTED NOISE RECEPTORS
	FEDERAL PROPERTIES		ALTERNATIVES A AND B
			ALTERNATIVE C
			ALTERNATIVE D

SCALE IN FEET: 0 300 600 1200

**Note:**  
 The information shown is for the purpose of determining cost estimates and environmental impacts and is subject to change during the final design phase. Any reliance upon these plans is made with full understanding of its draft status. Environmental impacts described in the SEIS are based on proposed limits of disturbance.

Aerial Imagery Copyright 2013 Commonwealth of Virginia

**HRCS SEIS**  
 Hampton Roads Crossing Study SEIS

**I-664 Alternative C**

**VDOT** July 2016

U.S. Department of Transportation  
**Federal Highway Administration** Figure 10C



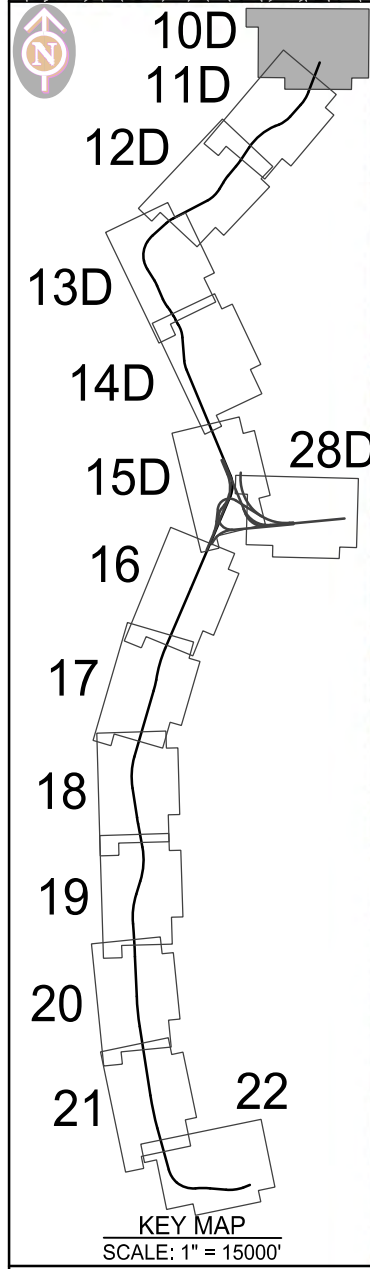

LEGEND	
	PROPOSED ROADWAY IMPROVEMENTS
	PROPOSED STRUCTURES
	PROPOSED LIMIT OF DISTURBANCE
	POTENTIAL DISPLACEMENTS
	WETLANDS / WATERS
	FEDERAL PROPERTIES
	HISTORIC PROPERTIES
	PARKS
	PARCEL BOUNDARY
	PROPOSED NOISE BARRIERS
	IMPACTED NOISE RECEPTORS
	ALTERNATIVES A AND B
	ALTERNATIVE C
	ALTERNATIVE D

**Note:**  
 The information shown is for the purpose of determining cost estimates and environmental impacts and is subject to change during the final design phase. Any reliance upon these plans is made with full understanding of its draft status. Environmental impacts described in the SEIS are based on proposed limits of disturbance.

Aerial Imagery Copyright 2013 Commonwealth of Virginia

**HRCS SEIS**  
 Hampton Roads Crossing Study SEIS

**I-664 Alternative D**

**VDOT** July 2016

U.S. Department of Transportation  
**Federal Highway Administration** Figure 10D

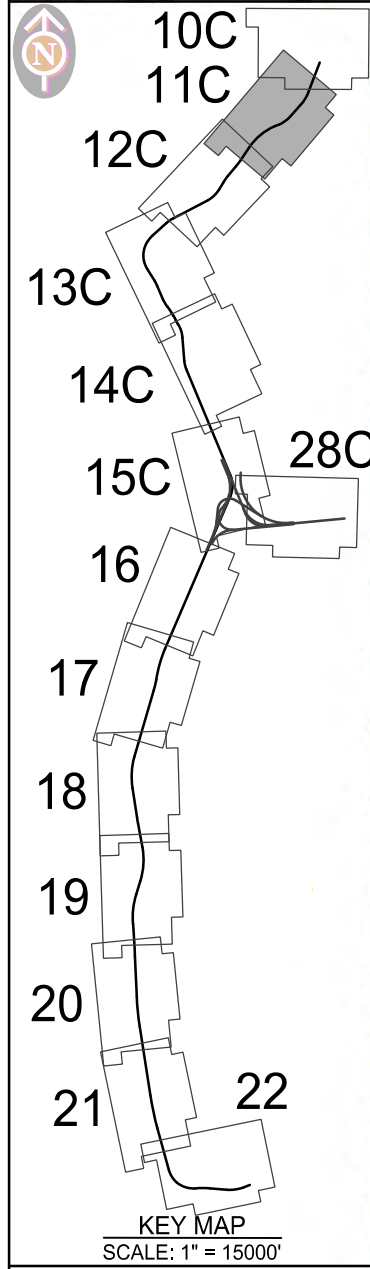
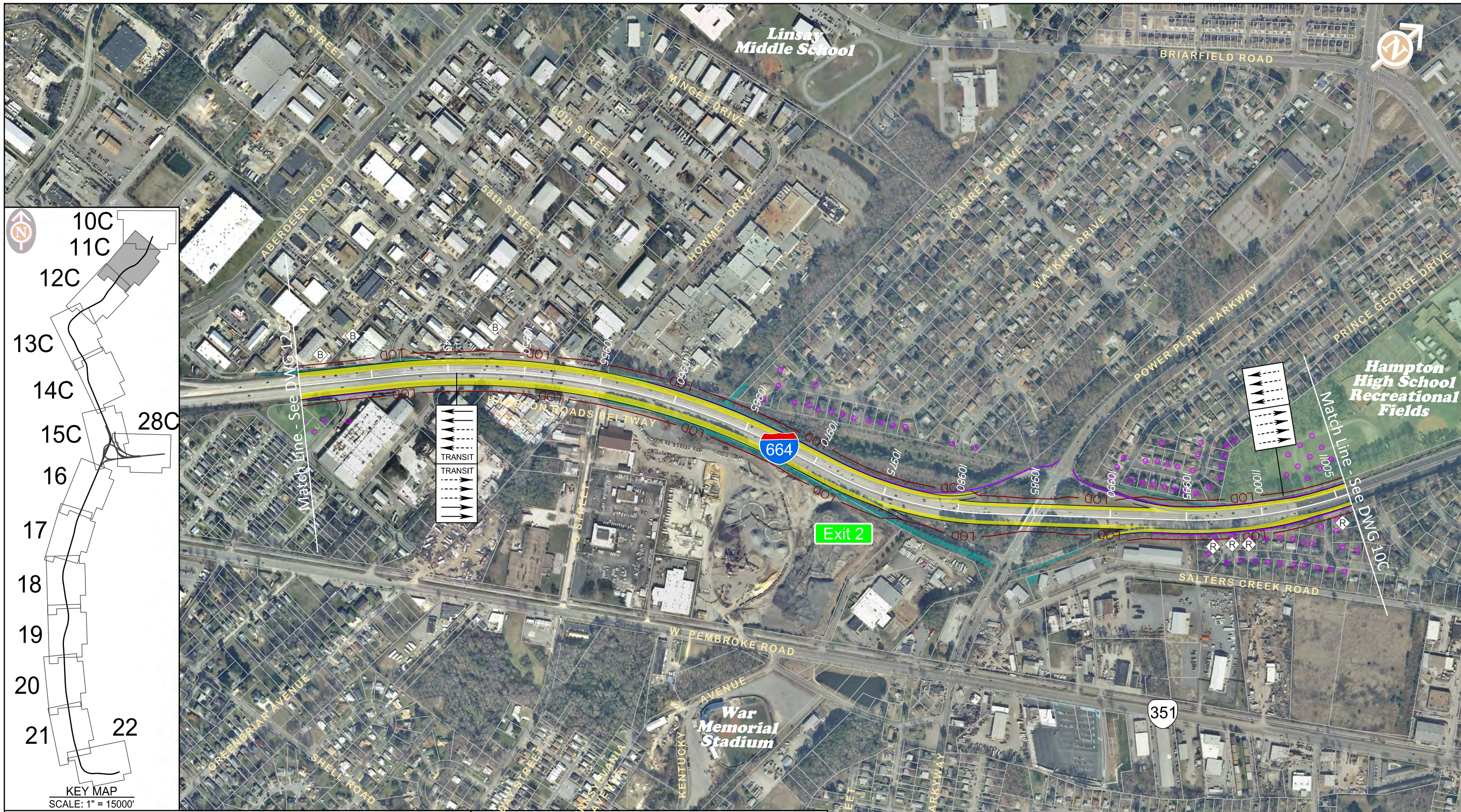

LEGEND	
	PROPOSED ROADWAY IMPROVEMENTS
	PROPOSED STRUCTURES
	PROPOSED LIMIT OF DISTURBANCE
	POTENTIAL DISPLACEMENTS
	WETLANDS / WATERS
	FEDERAL PROPERTIES
	HISTORIC PROPERTIES
	PARKS
	PARCEL BOUNDARY
	PROPOSED NOISE BARRIERS
	IMPACTED NOISE RECEPTORS
	ALTERNATIVES A AND B
	ALTERNATIVE C
	ALTERNATIVE D

**Note:**  
 The information shown is for the purpose of determining cost estimates and environmental impacts and is subject to change during the final design phase. Any reliance upon these plans is made with full understanding of its draft status. Environmental impacts described in the SEIS are based on proposed limits of disturbance.

Aerial Imagery Copyright 2013 Commonwealth of Virginia

**HRCS SEIS**  
 Hampton Roads Crossing Study SEIS

**I-664 Alternative C**

**VDOT** July 2016

U.S. Department of Transportation  
**Federal Highway Administration** Figure 11C



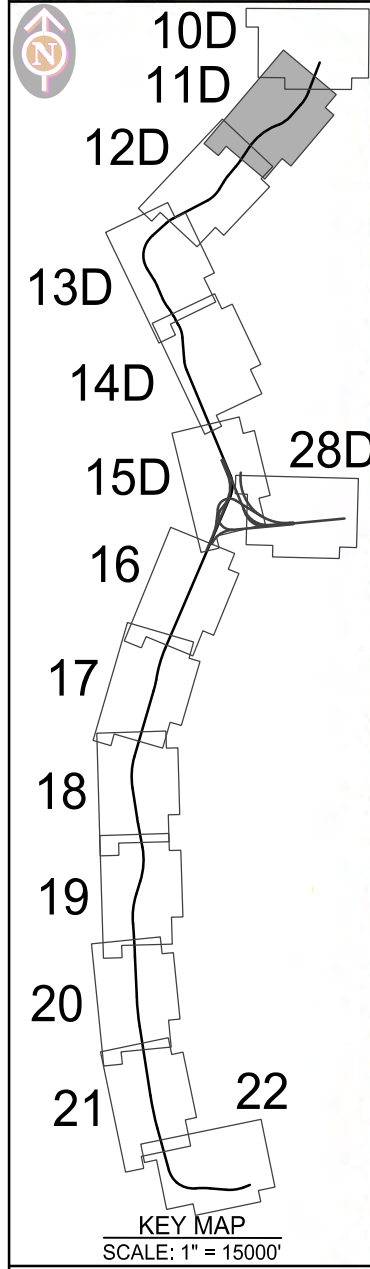
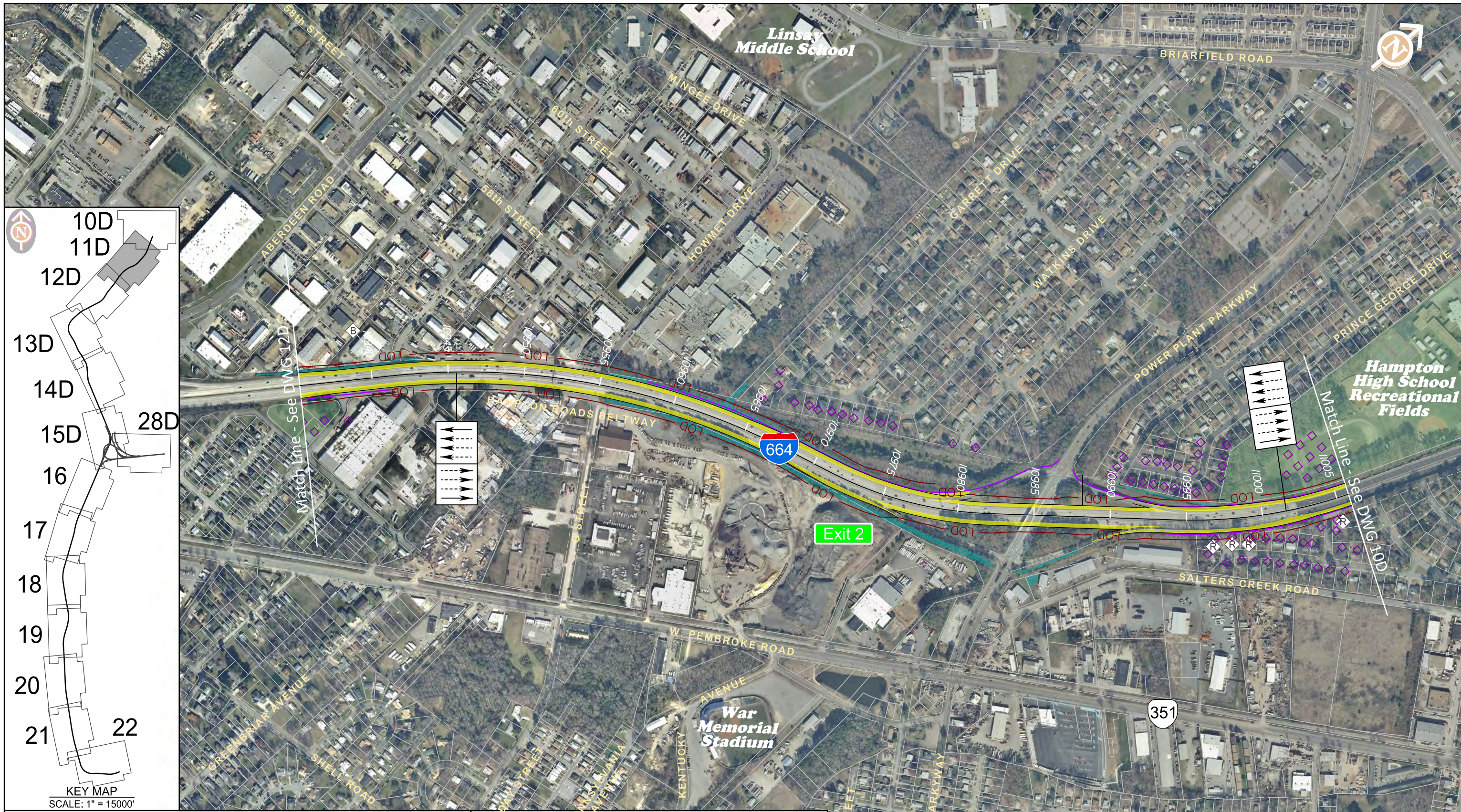

LEGEND	
	PROPOSED ROADWAY IMPROVEMENTS
	PROPOSED STRUCTURES
	PROPOSED LIMIT OF DISTURBANCE
	POTENTIAL DISPLACEMENTS
	WETLANDS / WATERS
	FEDERAL PROPERTIES
	HISTORIC PROPERTIES
	PARKS
	PARCEL BOUNDARY
	PROPOSED NOISE BARRIERS
	IMPACTED NOISE RECEPTORS
	ALTERNATIVES A AND B
	ALTERNATIVE C
	ALTERNATIVE D

Note:  
 The information shown is for the purpose of determining cost estimates and environmental impacts and is subject to change during the final design phase. Any reliance upon these plans is made with full understanding of its draft status. Environmental impacts described in the SEIS are based on proposed limits of disturbance.

Aerial Imagery Copyright 2013 Commonwealth of Virginia

**HRCS SEIS**  
 Hampton Roads Crossing Study SEIS

**I-664 Alternative D**

**VDOT** July 2016

U.S. Department of Transportation  
**Federal Highway Administration** Figure 11D



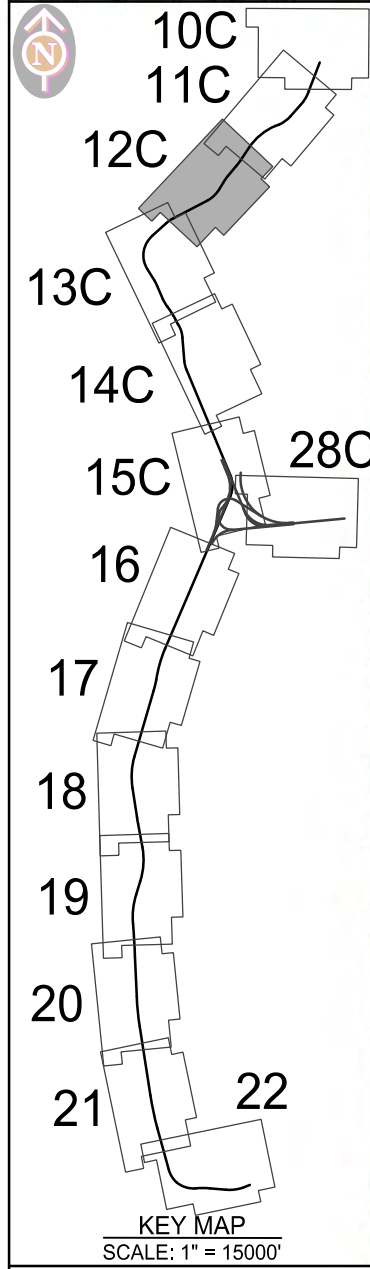
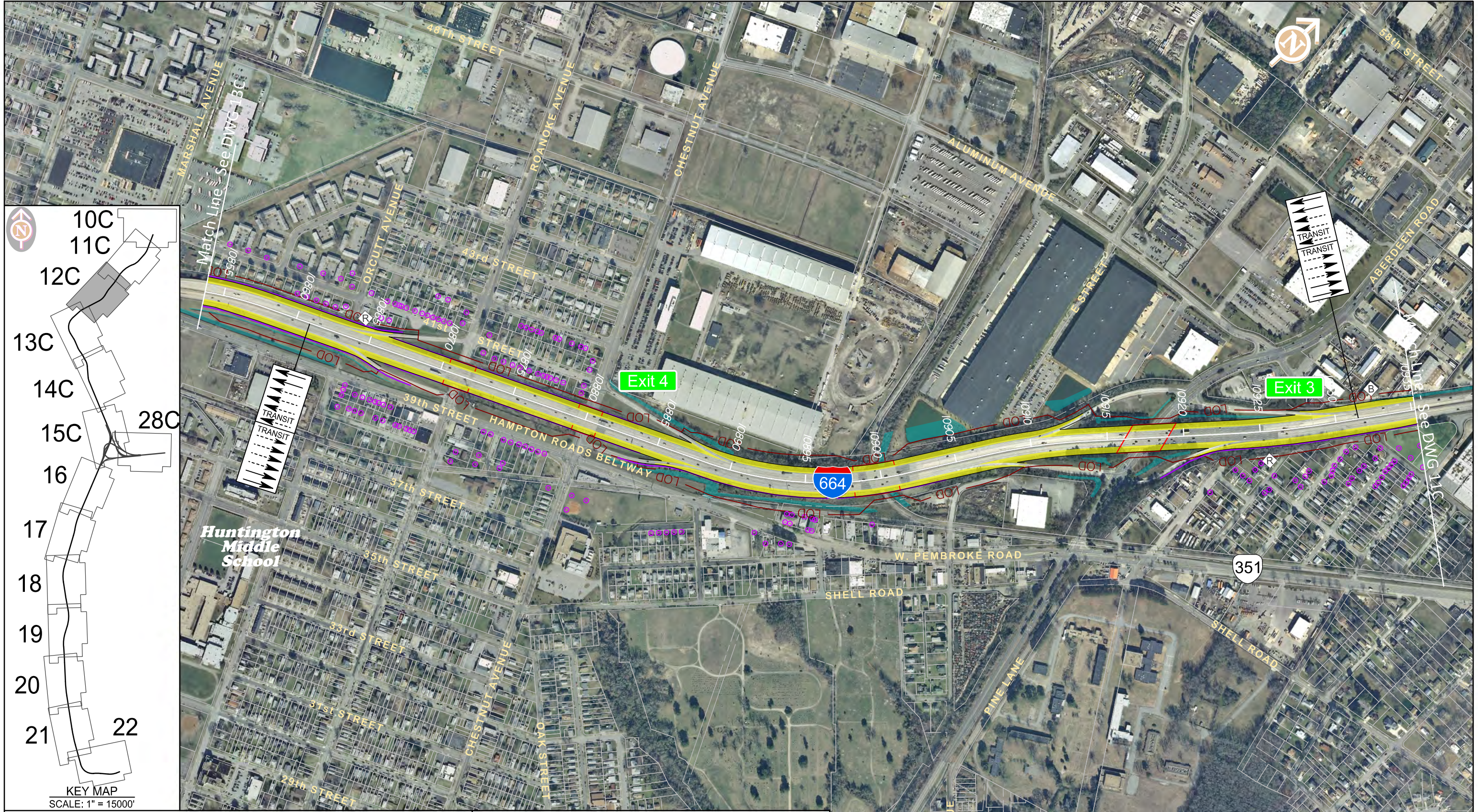

LEGEND	
	PROPOSED ROADWAY IMPROVEMENTS
	PROPOSED STRUCTURES
	PROPOSED LIMIT OF DISTURBANCE
	POTENTIAL DISPLACEMENTS
	WETLANDS / WATERS
	FEDERAL PROPERTIES
	HISTORIC PROPERTIES
	PARKS
	PARCEL BOUNDARY
	PROPOSED NOISE BARRIERS
	IMPACTED NOISE RECEPTORS
	ALTERNATIVES A AND B
	ALTERNATIVE C
	ALTERNATIVE D

Note:  
The information shown is for the purpose of determining cost estimates and environmental impacts and is subject to change during the final design phase. Any reliance upon these plans is made with full understanding of its draft status. Environmental impacts described in the SEIS are based on proposed limits of disturbance.

Aerial Imagery Copyright 2013 Commonwealth of Virginia

**HRCs SEIS**  
Hampton Roads Crossing Study SEIS

**I-664 Alternative C**

**VDOT** July 2016

U.S. Department of Transportation  
**Federal Highway Administration** Figure 12C

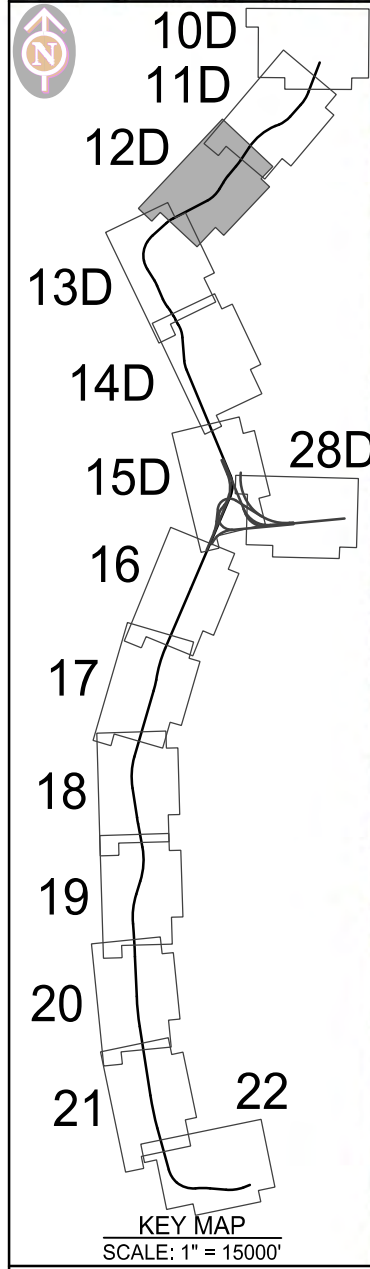
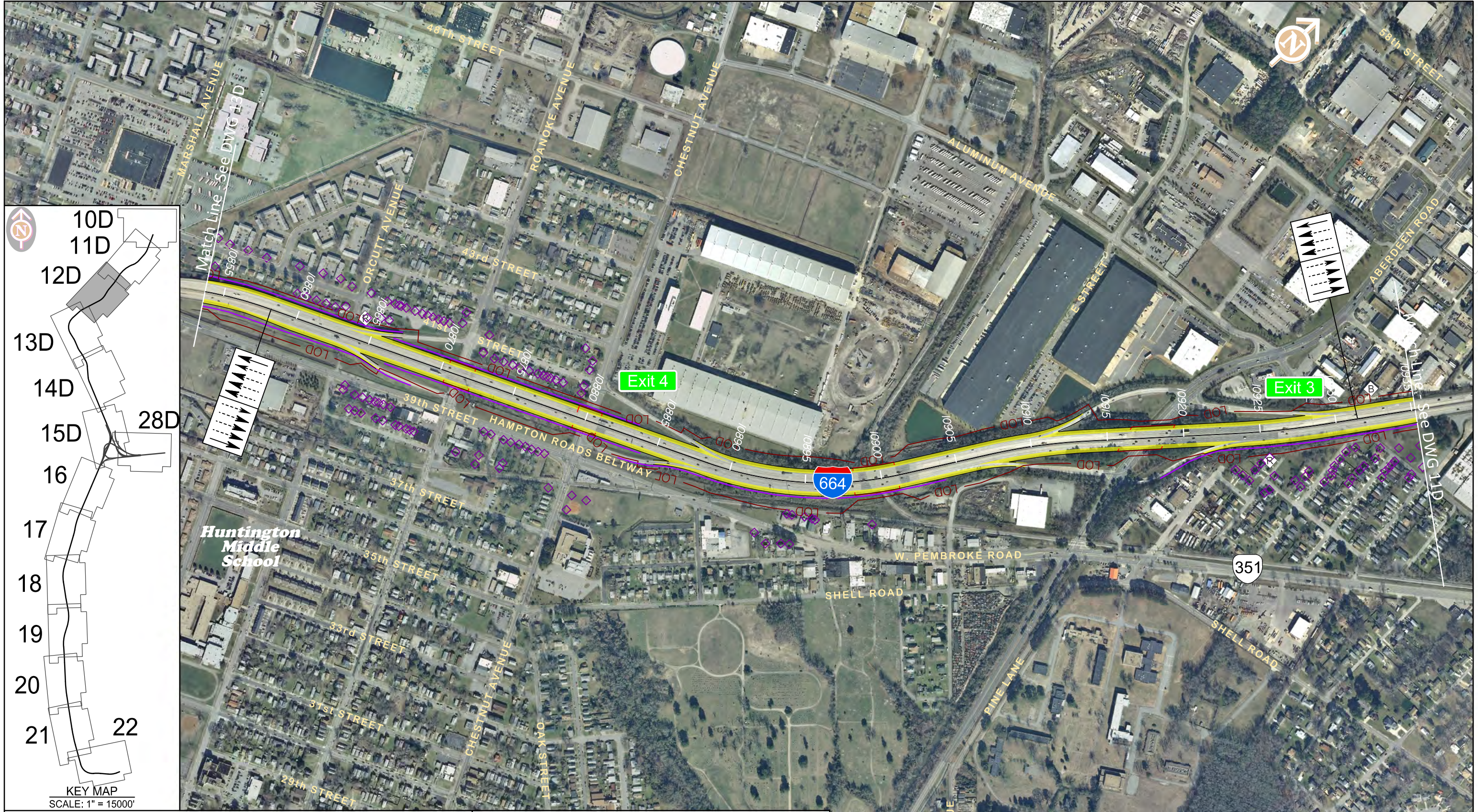

LEGEND	
	PROPOSED ROADWAY IMPROVEMENTS
	PROPOSED STRUCTURES
	PROPOSED LIMIT OF DISTURBANCE
	POTENTIAL DISPLACEMENTS
	WETLANDS / WATERS
	FEDERAL PROPERTIES
	HISTORIC PROPERTIES
	PARKS
	PARCEL BOUNDARY
	PROPOSED NOISE BARRIERS
	IMPACTED NOISE RECEPTORS
	ALTERNATIVES A AND B
	ALTERNATIVE C
	ALTERNATIVE D

Note:  
The information shown is for the purpose of determining cost estimates and environmental impacts and is subject to change during the final design phase. Any reliance upon these plans is made with full understanding of its draft status. Environmental impacts described in the SEIS are based on proposed limits of disturbance.

Aerial Imagery Copyright 2013 Commonwealth of Virginia

**HRCs SEIS**  
Hampton Roads Crossing Study SEIS

**I-664 Alternative D**

**VDOT** July 2016

U.S. Department of Transportation  
**Federal Highway Administration** Figure 12D

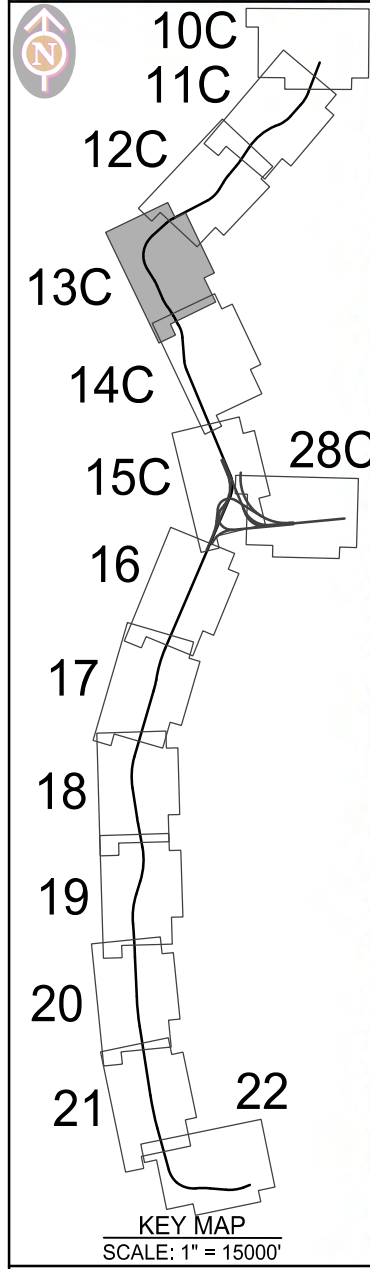

LEGEND	
	PROPOSED ROADWAY IMPROVEMENTS
	PROPOSED STRUCTURES
	PROPOSED LIMIT OF DISTURBANCE
	POTENTIAL DISPLACEMENTS
	WETLANDS / WATERS
	FEDERAL PROPERTIES
	HISTORIC PROPERTIES
	PARKS
	PARCEL BOUNDARY
	PROPOSED NOISE BARRIERS
	IMPACTED NOISE RECEPTORS
	ALTERNATIVES A AND B
	ALTERNATIVE C
	ALTERNATIVE D

**Note:**  
 The information shown is for the purpose of determining cost estimates and environmental impacts and is subject to change during the final design phase. Any reliance upon these plans is made with full understanding of its draft status. Environmental impacts described in the SEIS are based on proposed limits of disturbance.

Aerial Imagery Copyright 2013 Commonwealth of Virginia

**HRCS SEIS**  
 Hampton Roads Crossing Study SEIS

**I-664 Alternative C**

**VDOT** July 2016

U.S. Department of Transportation  
**Federal Highway Administration** Figure 13C

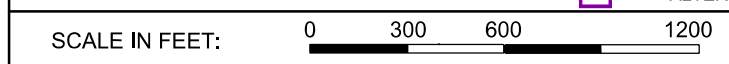

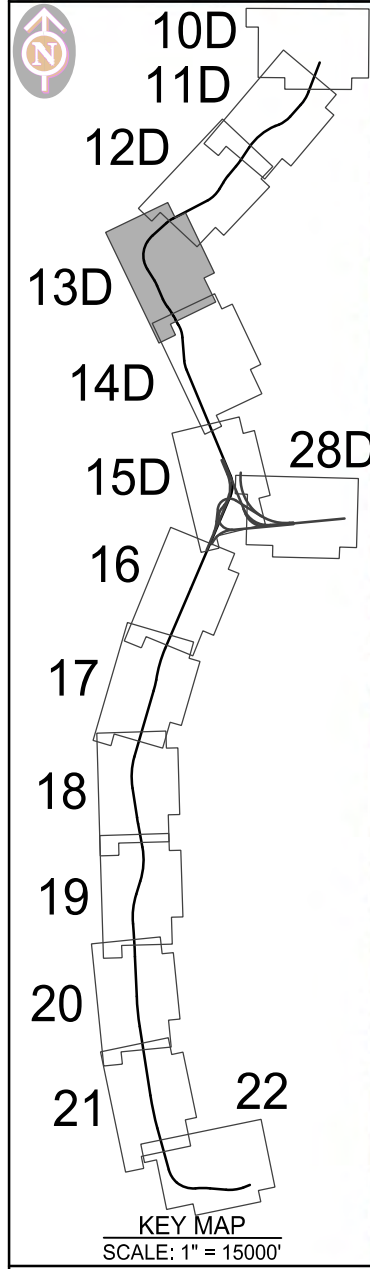
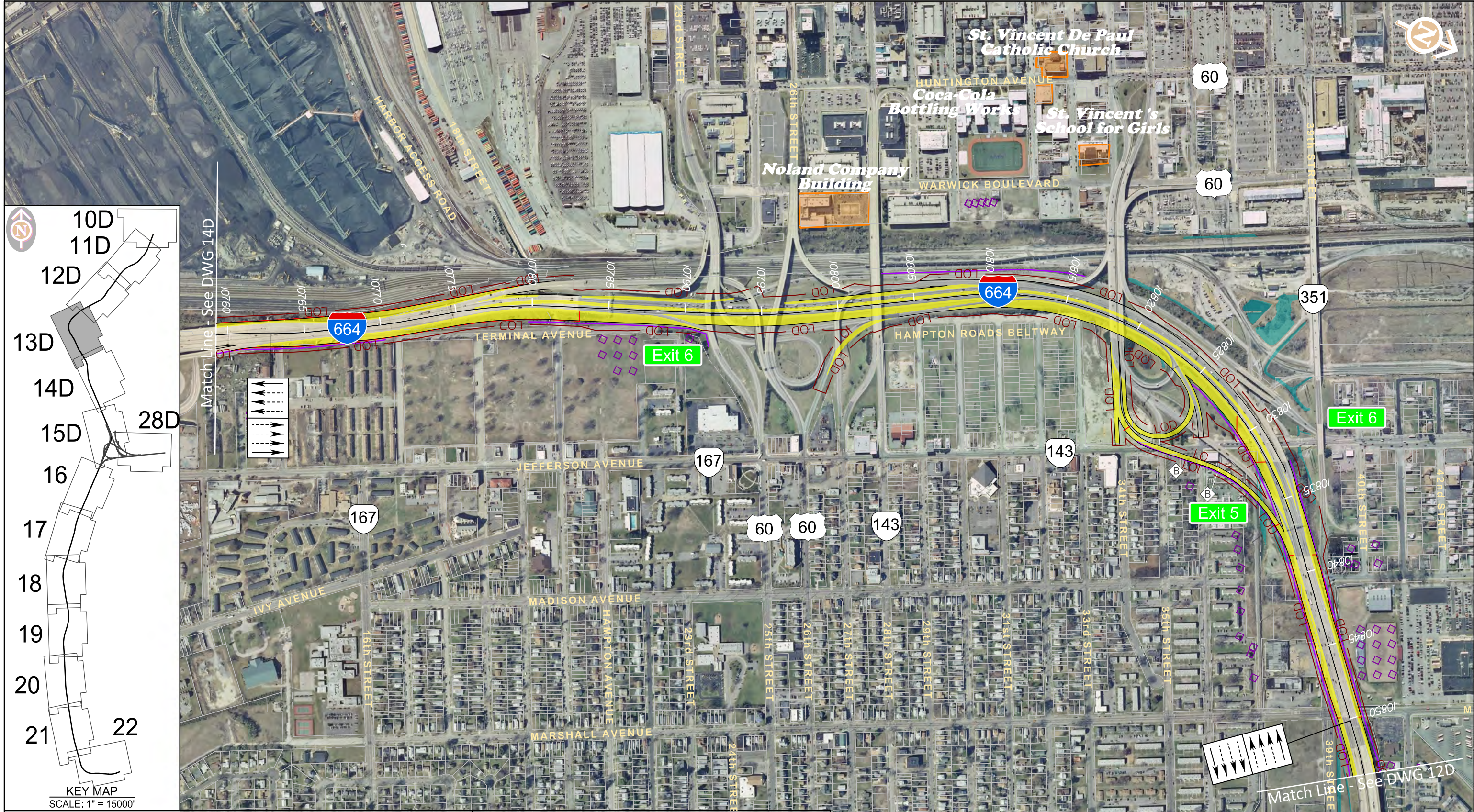

LEGEND	
	PROPOSED ROADWAY IMPROVEMENTS
	PROPOSED STRUCTURES
	PROPOSED LIMIT OF DISTURBANCE
	POTENTIAL DISPLACEMENTS
	WETLANDS / WATERS
	FEDERAL PROPERTIES
	HISTORIC PROPERTIES
	PARKS
	PARCEL BOUNDARY
	PROPOSED NOISE BARRIERS
	IMPACTED NOISE RECEPTORS
	ALTERNATIVES A AND B
	ALTERNATIVE C
	ALTERNATIVE D

**Note:**  
 The information shown is for the purpose of determining cost estimates and environmental impacts and is subject to change during the final design phase. Any reliance upon these plans is made with full understanding of its draft status. Environmental impacts described in the SEIS are based on proposed limits of disturbance.

Aerial Imagery Copyright 2013 Commonwealth of Virginia

**HRCs SEIS**  
 Hampton Roads Crossing Study SEIS

**I-664 Alternative D**

**VDOT** July 2016

U.S. Department of Transportation  
**Federal Highway Administration** Figure 13D

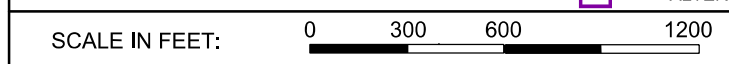

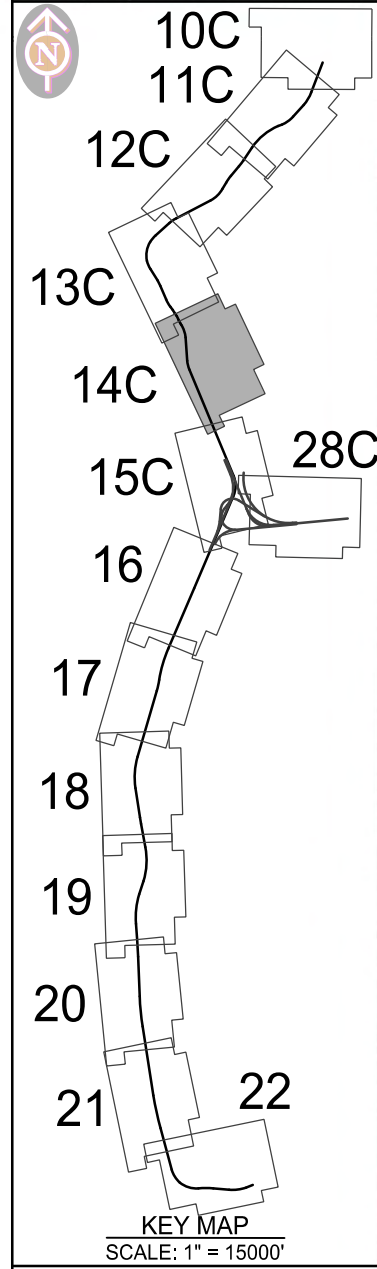

LEGEND	
	PROPOSED ROADWAY IMPROVEMENTS
	PROPOSED STRUCTURES
	PROPOSED LIMIT OF DISTURBANCE
	POTENTIAL DISPLACEMENTS
	WETLANDS / WATERS
	FEDERAL PROPERTIES
	HISTORIC PROPERTIES
	PARKS
	PARCEL BOUNDARY
	PROPOSED NOISE BARRIERS
	IMPACTED NOISE RECEPTORS
	ALTERNATIVES A AND B
	ALTERNATIVE C
	ALTERNATIVE D

**Note:**  
 The information shown is for the purpose of determining cost estimates and environmental impacts and is subject to change during the final design phase. Any reliance upon these plans is made with full understanding of its draft status. Environmental impacts described in the SEIS are based on proposed limits of disturbance.

Aerial Imagery Copyright 2013 Commonwealth of Virginia

**HRCs SEIS**  
 Hampton Roads Crossing Study SEIS

**I-664 Alternative C**

**VDOT**  
 VIRGINIA DEPARTMENT OF TRANSPORTATION

July 2016

U.S. Department of Transportation  
**Federal Highway Administration**

Figure 14C



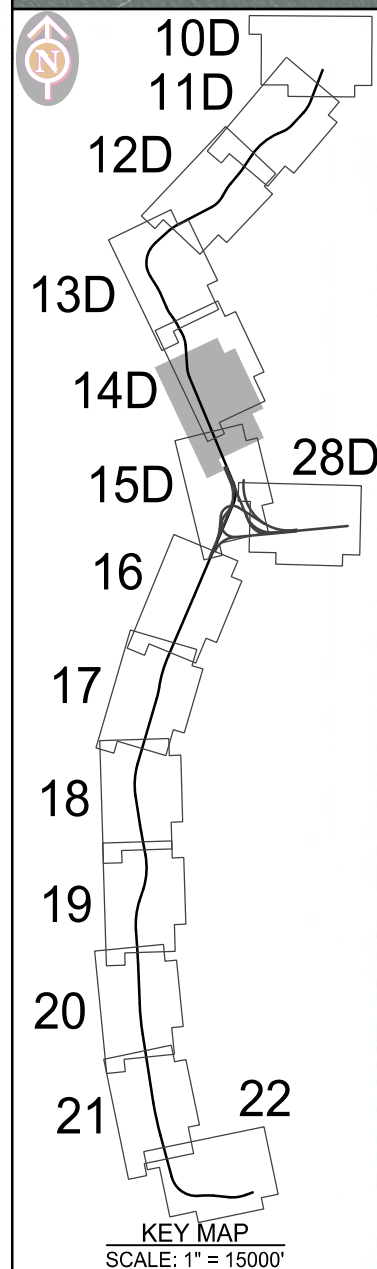

LEGEND	
	PROPOSED ROADWAY IMPROVEMENTS
	PROPOSED LIMIT OF DISTURBANCE
	POTENTIAL DISPLACEMENTS
	WETLANDS / WATERS
	FEDERAL PROPERTIES
	HISTORIC PROPERTIES
	PARKS
	PARCEL BOUNDARY
	PROPOSED NOISE BARRIERS
	IMPACTED NOISE RECEPTORS
	ALTERNATIVES A AND B
	ALTERNATIVE C
	ALTERNATIVE D

**Note:**  
 The information shown is for the purpose of determining cost estimates and environmental impacts and is subject to change during the final design phase. Any reliance upon these plans is made with full understanding of its draft status. Environmental impacts described in the SEIS are based on proposed limits of disturbance.

Aerial Imagery Copyright 2013 Commonwealth of Virginia

**HRCs SEIS**  
 Hampton Roads Crossing Study SEIS

**I-664 Alternative D**

**VDOT**  
 Virginia Department of Transportation

July 2016

U.S. Department of Transportation  
**Federal Highway Administration**

Figure 14D



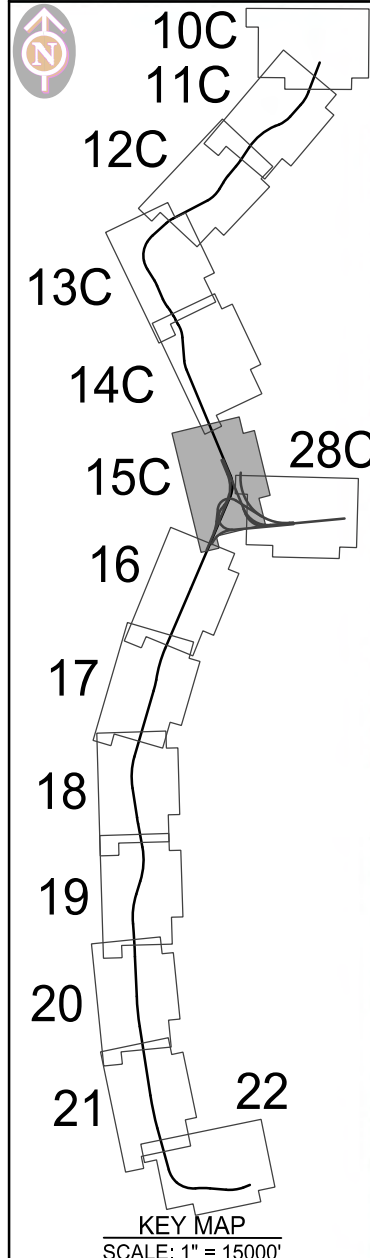
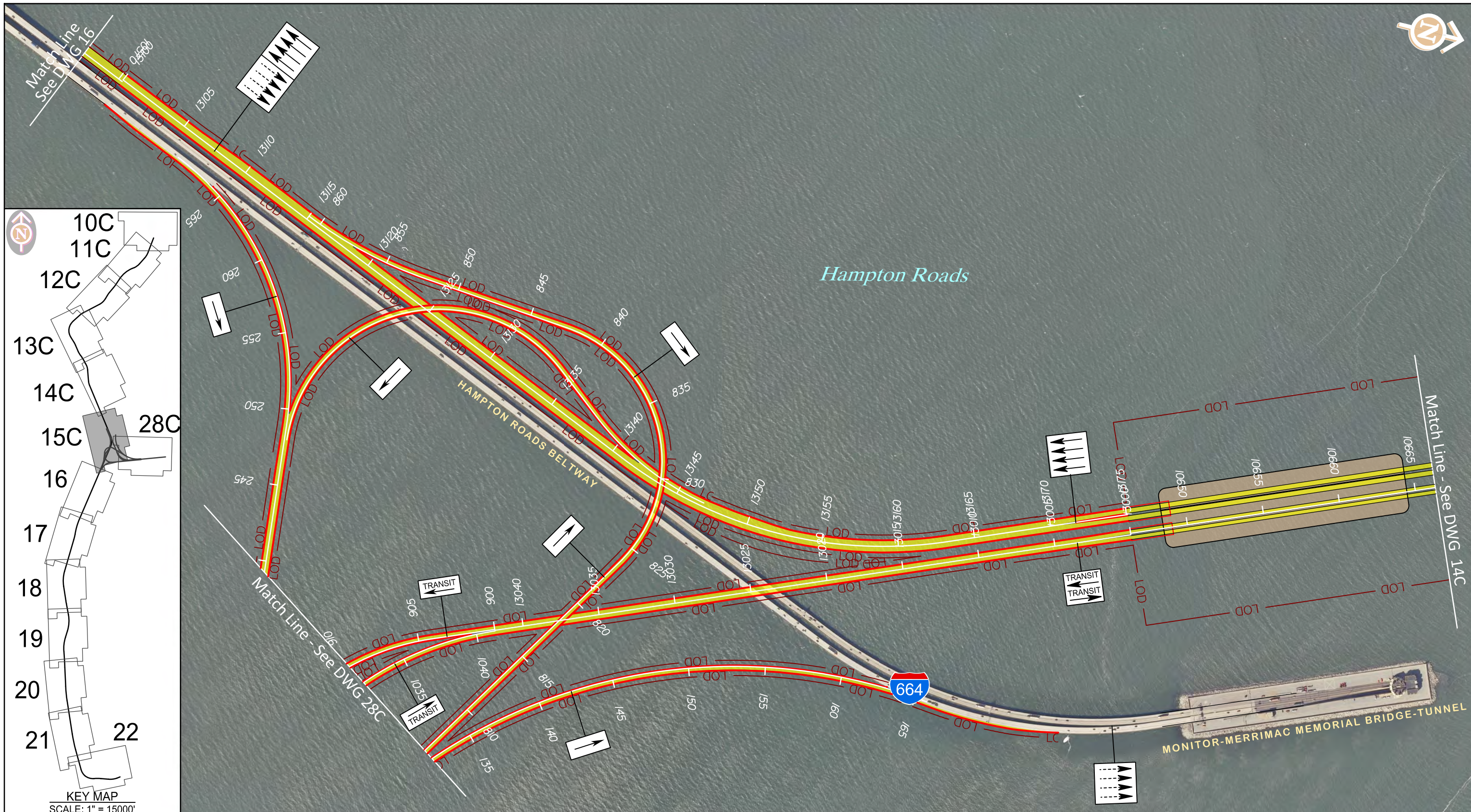

LEGEND	
	PROPOSED ROADWAY IMPROVEMENTS
	PROPOSED STRUCTURES
	PROPOSED LIMIT OF DISTURBANCE
	POTENTIAL DISPLACEMENTS
	WETLANDS / WATERS
	FEDERAL PROPERTIES
	HISTORIC PROPERTIES
	PARKS
	PARCEL BOUNDARY
	PROPOSED NOISE BARRIERS
	IMPACTED NOISE RECEPTORS
	ALTERNATIVES A AND B
	ALTERNATIVE C
	ALTERNATIVE D

**Note:**  
The information shown is for the purpose of determining cost estimates and environmental impacts and is subject to change during the final design phase. Any reliance upon these plans is made with full understanding of its draft status. Environmental impacts described in the SEIS are based on proposed limits of disturbance.

Aerial Imagery Copyright 2013 Commonwealth of Virginia

**HRCs SEIS**  
Hampton Roads Crossing Study SEIS

**I-664 Alternative C**

**VDOT**  
Virginia Department of Transportation

July 2016

U.S. Department of Transportation  
**Federal Highway Administration**

Figure 15C



**LEGEND**

	PROPOSED ROADWAY IMPROVEMENTS		HISTORIC PROPERTIES
	PROPOSED STRUCTURES		PARKS
	PROPOSED LIMIT OF DISTURBANCE		PARCEL BOUNDARY
	POTENTIAL DISPLACEMENTS		PROPOSED NOISE BARRIERS
	WETLANDS / WATERS		IMPACTED NOISE RECEPTORS
	FEDERAL PROPERTIES		ALTERNATIVES A AND B
			ALTERNATIVE C
			ALTERNATIVE D

SCALE IN FEET: 0 300 600 1200

**Note:**  
 The information shown is for the purpose of determining cost estimates and environmental impacts and is subject to change during the final design phase. Any reliance upon these plans is made with full understanding of its draft status. Environmental impacts described in the SEIS are based on proposed limits of disturbance.

Aerial Imagery Copyright 2013 Commonwealth of Virginia

**HRCS SEIS**  
 Hampton Roads Crossing Study SEIS

**I-664 Alternative D**

July 2016

U.S. Department of Transportation  
 Federal Highway Administration Figure 15D

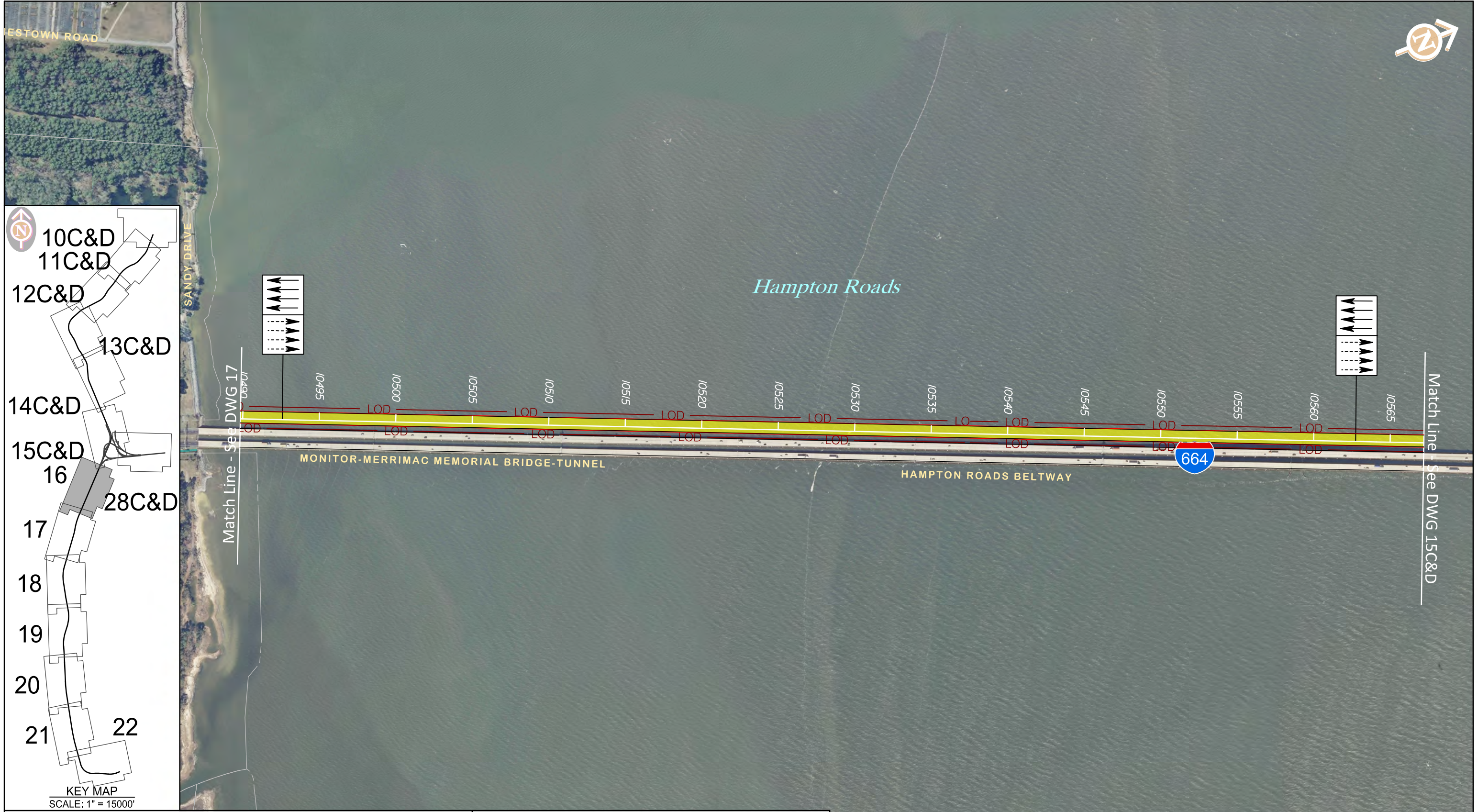

**LEGEND**

	PROPOSED ROADWAY IMPROVEMENTS		HISTORIC PROPERTIES
	PROPOSED STRUCTURES		PARKS
	PROPOSED LIMIT OF DISTURBANCE		PARCEL BOUNDARY
	POTENTIAL DISPLACEMENTS		PROPOSED NOISE BARRIERS
	WETLANDS / WATERS		IMPACTED NOISE RECEPTORS
	FEDERAL PROPERTIES		ALTERNATIVES A AND B
			ALTERNATIVE C
			ALTERNATIVE D

SCALE IN FEET: 0 300 600 1200

**Note:**  
 The information shown is for the purpose of determining cost estimates and environmental impacts and is subject to change during the final design phase. Any reliance upon these plans is made with full understanding of its draft status. Environmental impacts described in the SEIS are based on proposed limits of disturbance.

Aerial Imagery Copyright 2013 Commonwealth of Virginia

**HRCS SEIS**  
 Hampton Roads Crossing Study SEIS

**I-664**  
 Alternatives C and D

**VDOT**  
 Virginia Department of Transportation

July 2016

U.S. Department of Transportation  
**Federal Highway Administration**

Figure 16

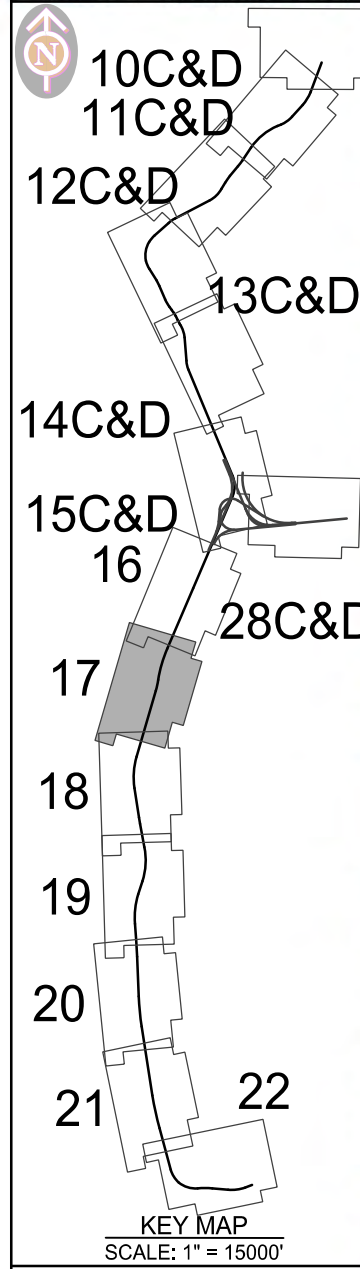
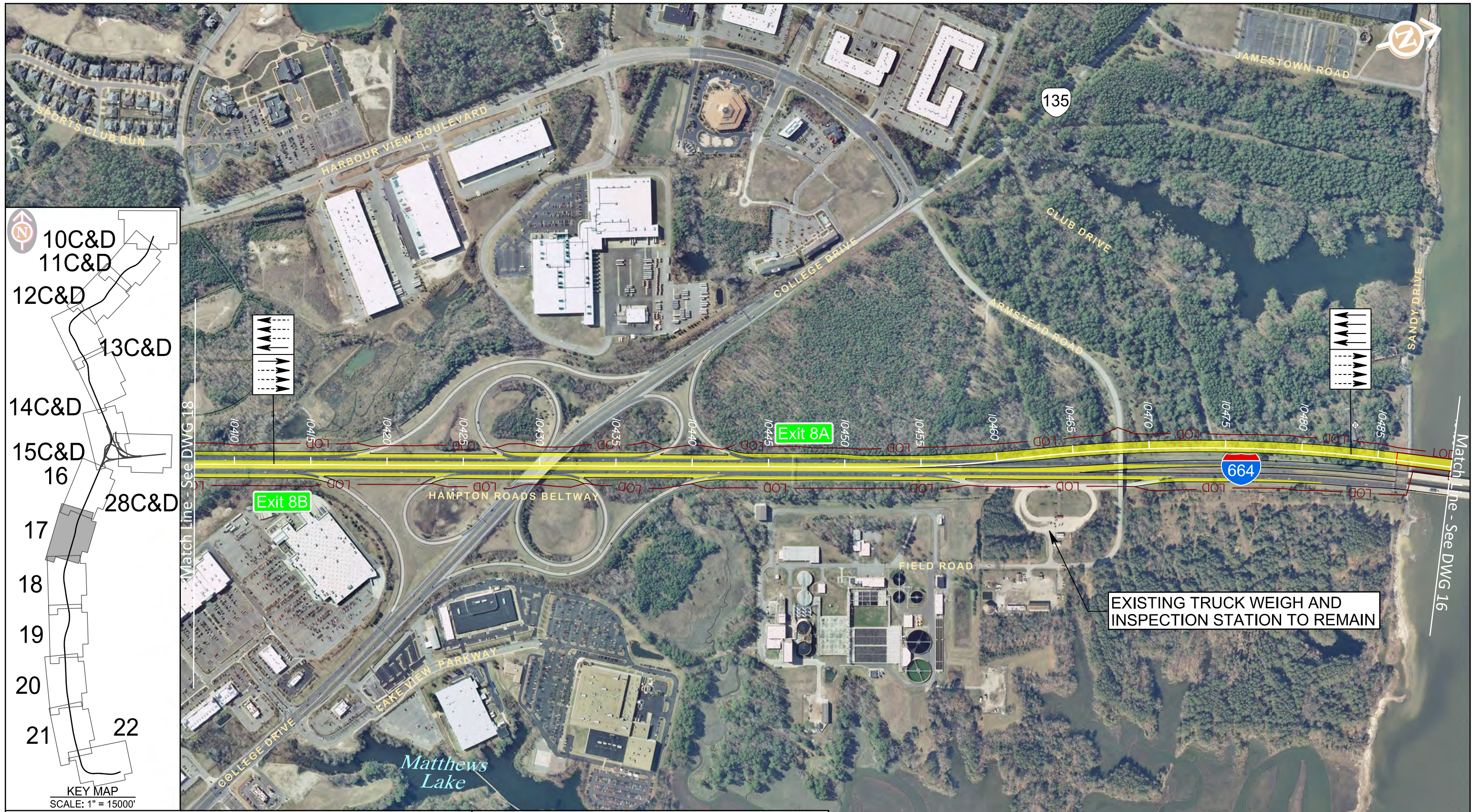

LEGEND	
	PROPOSED ROADWAY IMPROVEMENTS
	PROPOSED STRUCTURES
	PROPOSED LIMIT OF DISTURBANCE
	POTENTIAL DISPLACEMENTS
	WETLANDS / WATERS
	FEDERAL PROPERTIES
	HISTORIC PROPERTIES
	PARKS
	PARCEL BOUNDARY
	PROPOSED NOISE BARRIERS
	IMPACTED NOISE RECEPTORS
	ALTERNATIVES A AND B
	ALTERNATIVE C
	ALTERNATIVE D

**Note:**  
 The information shown is for the purpose of determining cost estimates and environmental impacts and is subject to change during the final design phase. Any reliance upon these plans is made with full understanding of its draft status. Environmental impacts described in the SEIS are based on proposed limits of disturbance.

Aerial Imagery Copyright 2013 Commonwealth of Virginia

**HRCs SEIS**  
 Hampton Roads Crossing Study SEIS

I-664  
 Alternatives C and D

**VDOT**  
 Virginia Department of Transportation

U.S. Department of Transportation  
**Federal Highway Administration**

July 2016  
 Figure 17

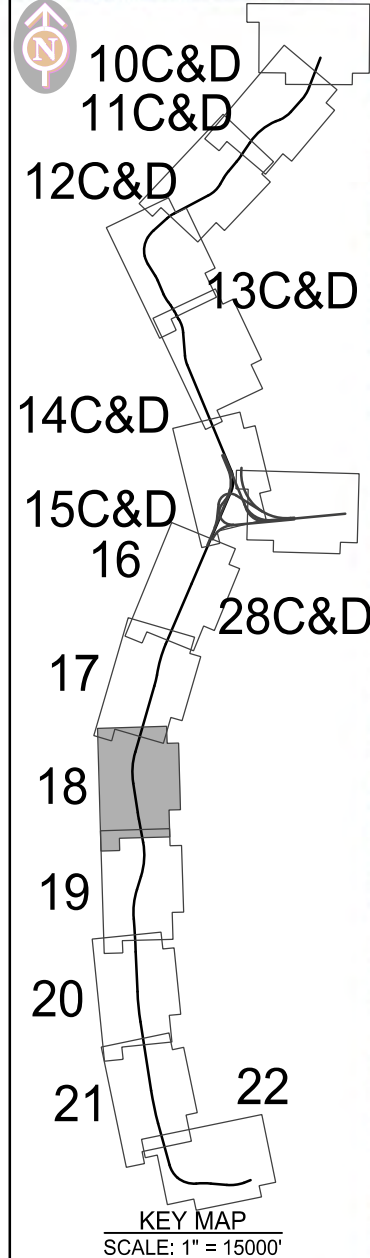
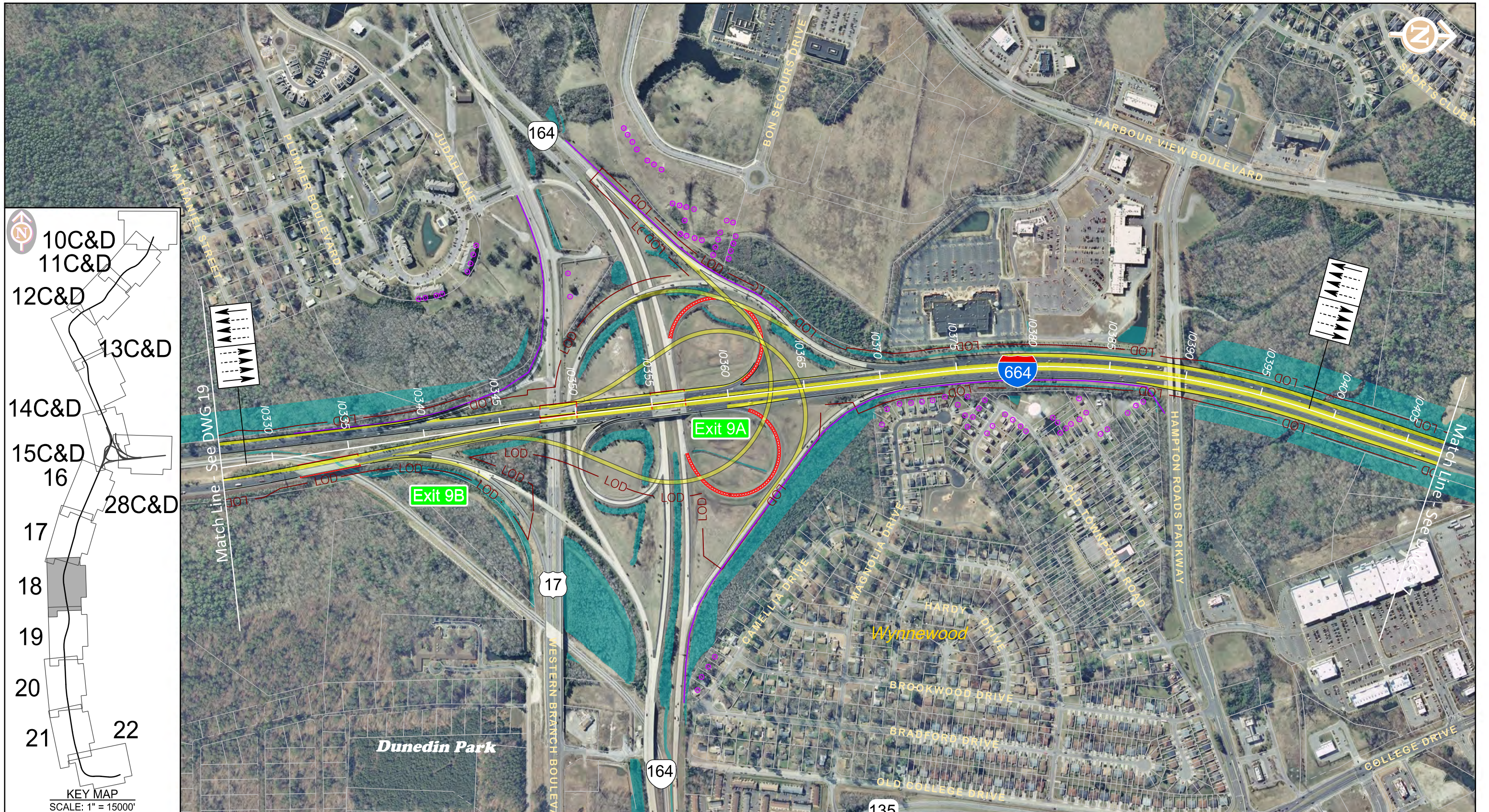

LEGEND	
	PROPOSED ROADWAY IMPROVEMENTS
	PROPOSED STRUCTURES
	PROPOSED LIMIT OF DISTURBANCE
	POTENTIAL DISPLACEMENTS
	WETLANDS / WATERS
	FEDERAL PROPERTIES
	HISTORIC PROPERTIES
	PARKS
	PARCEL BOUNDARY
	PROPOSED NOISE BARRIERS
	IMPACTED NOISE RECEPTORS
	ALTERNATIVES A AND B
	ALTERNATIVE C
	ALTERNATIVE D

**Note:**  
The information shown is for the purpose of determining cost estimates and environmental impacts and is subject to change during the final design phase. Any reliance upon these plans is made with full understanding of its draft status. Environmental impacts described in the SEIS are based on proposed limits of disturbance.

Aerial Imagery Copyright 2013 Commonwealth of Virginia

**HRCS SEIS**  
Hampton Roads Crossing Study SEIS

**I-664**  
Alternatives C and D

**VDOT**  
Virginia Department of Transportation

July 2016

U.S. Department of Transportation  
**Federal Highway Administration**

Figure 18

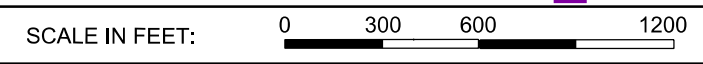

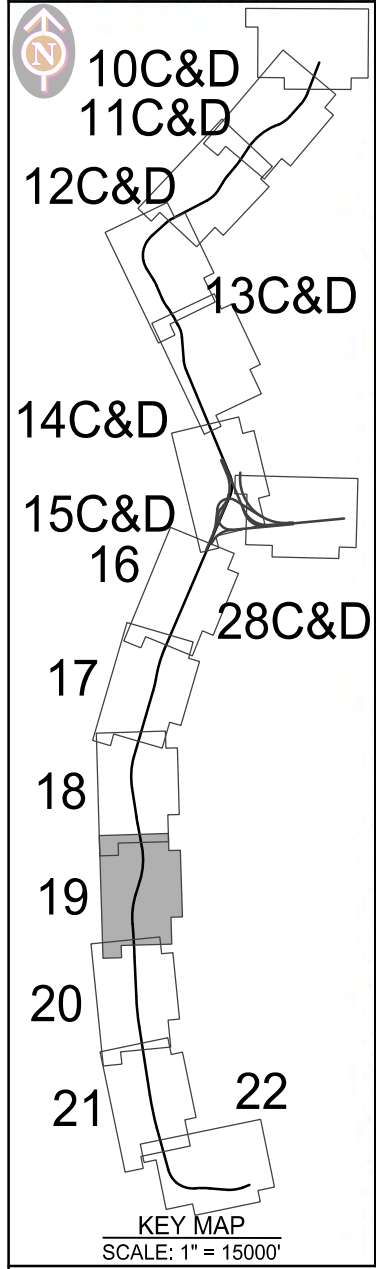
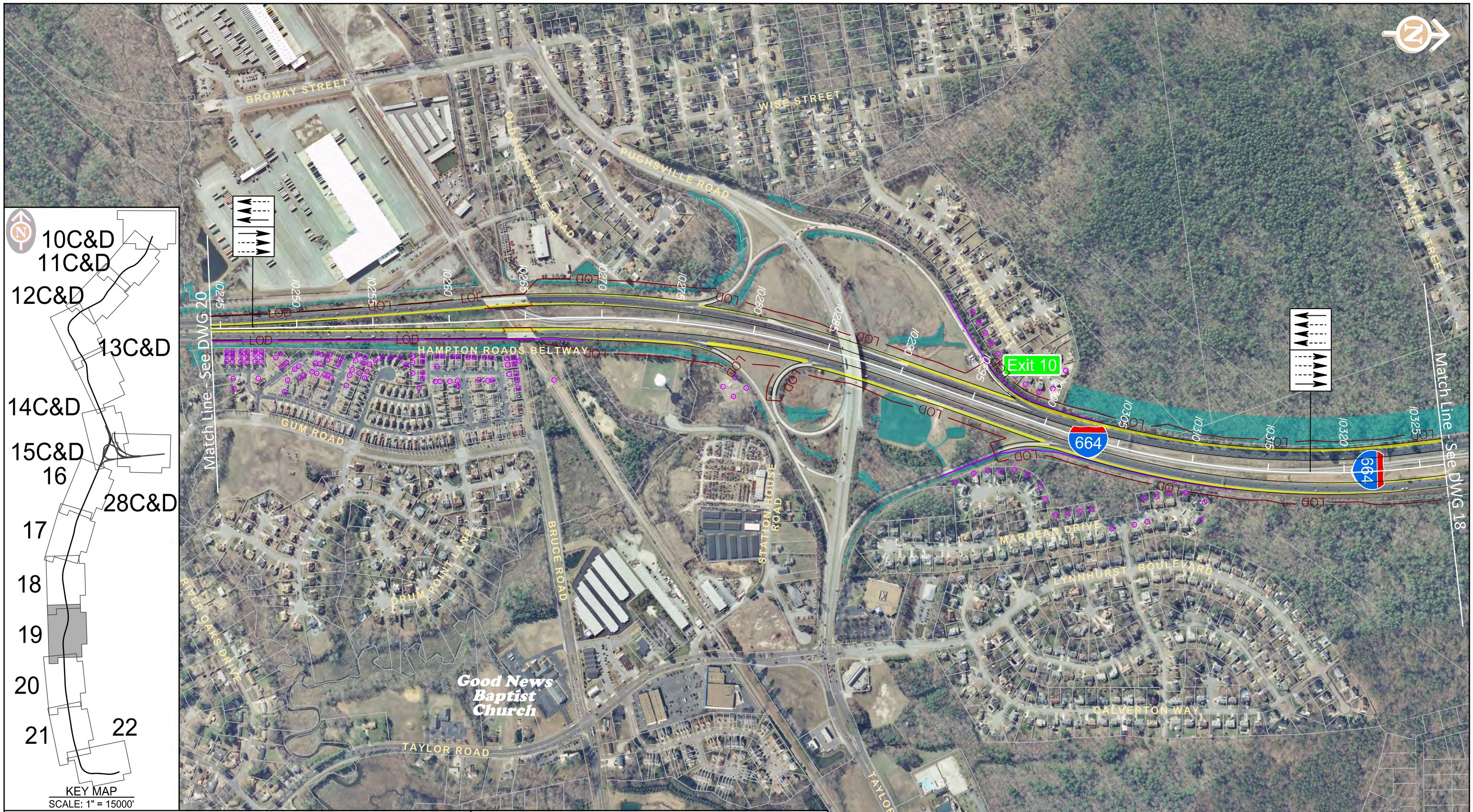

LEGEND	
	PROPOSED ROADWAY IMPROVEMENTS
	PROPOSED STRUCTURES
	PROPOSED LIMIT OF DISTURBANCE
	POTENTIAL DISPLACEMENTS
	WETLANDS / WATERS
	FEDERAL PROPERTIES
	HISTORIC PROPERTIES
	PARKS
	PARCEL BOUNDARY
	PROPOSED NOISE BARRIERS
	IMPACTED NOISE RECEPTORS
	ALTERNATIVES A AND B
	ALTERNATIVE C
	ALTERNATIVE D

**Note:**  
 The information shown is for the purpose of determining cost estimates and environmental impacts and is subject to change during the final design phase. Any reliance upon these plans is made with full understanding of its draft status. Environmental impacts described in the SEIS are based on proposed limits of disturbance.

Aerial Imagery Copyright 2013 Commonwealth of Virginia

**HRCS SEIS**  
 Hampton Roads Crossing Study SEIS

**I-664**  
 Alternatives C and D

**VDOT**  
 Virginia Department of Transportation

July 2016

U.S. Department of Transportation  
**Federal Highway Administration**

Figure 19



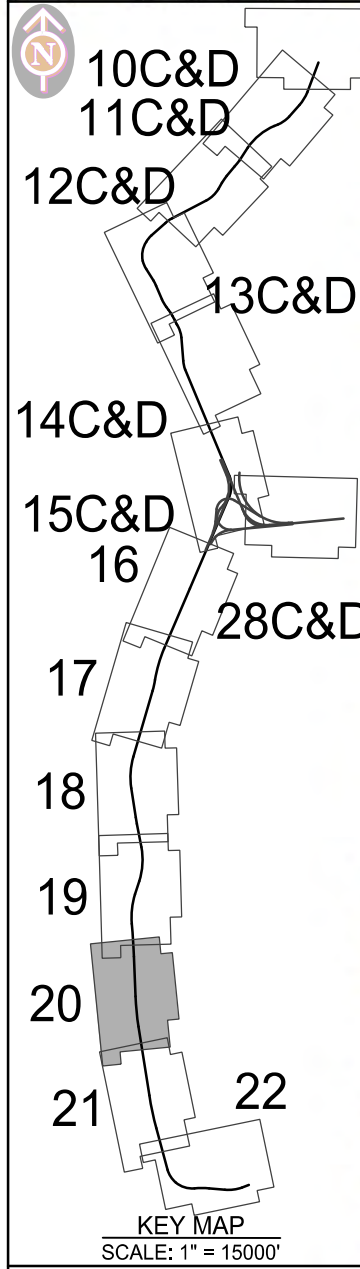
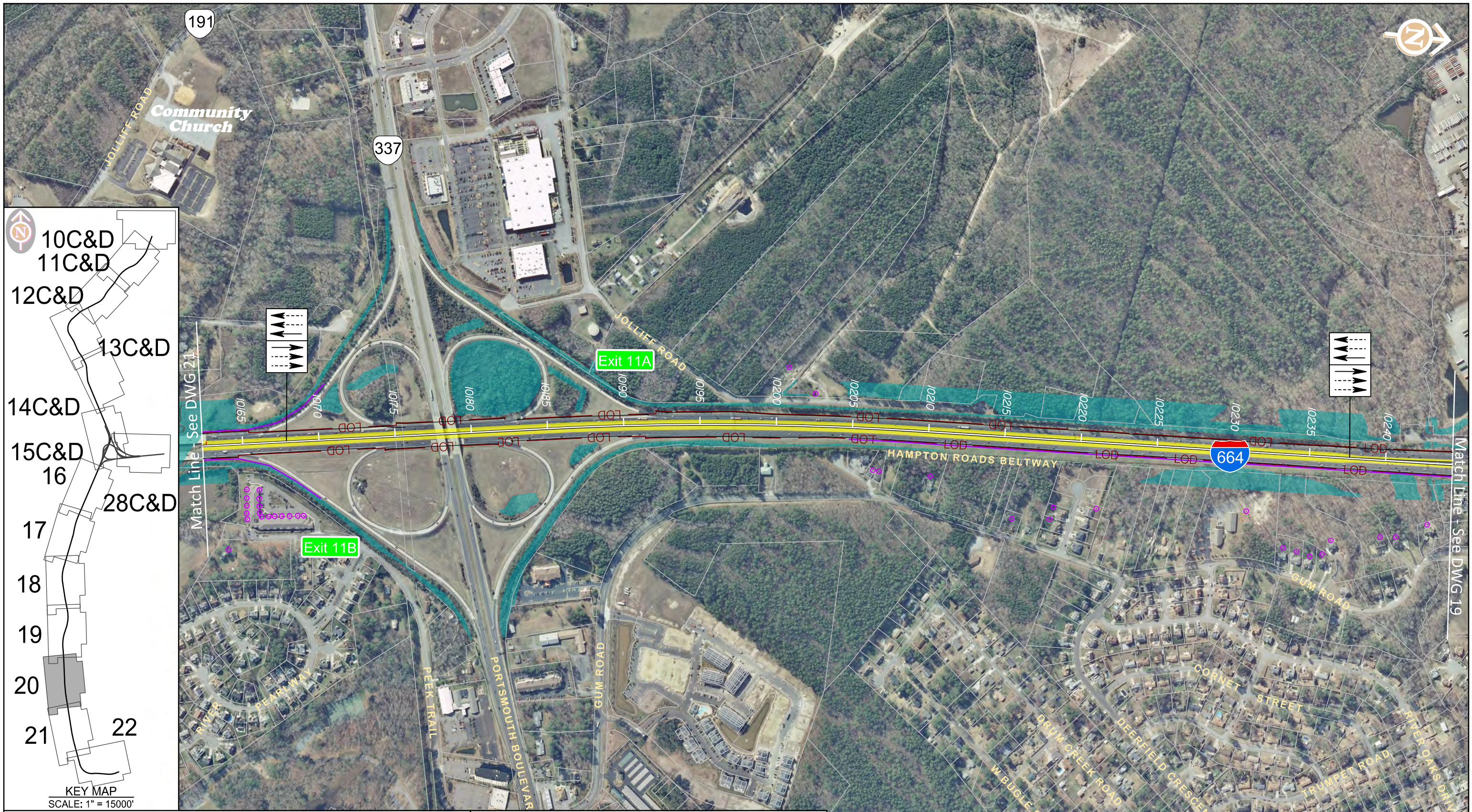

LEGEND	
	PROPOSED ROADWAY IMPROVEMENTS
	PROPOSED STRUCTURES
	PROPOSED LIMIT OF DISTURBANCE
	POTENTIAL DISPLACEMENTS
	WETLANDS / WATERS
	FEDERAL PROPERTIES
	HISTORIC PROPERTIES
	PARKS
	PARCEL BOUNDARY
	PROPOSED NOISE BARRIERS
	IMPACTED NOISE RECEPTORS
	ALTERNATIVES A AND B
	ALTERNATIVE C
	ALTERNATIVE D

**Note:**  
 The information shown is for the purpose of determining cost estimates and environmental impacts and is subject to change during the final design phase. Any reliance upon these plans is made with full understanding of its draft status. Environmental impacts described in the SEIS are based on proposed limits of disturbance.

Aerial Imagery Copyright 2013 Commonwealth of Virginia

**HRCs SEIS**  
 Hampton Roads Crossing Study SEIS

**I-664**  
 Alternatives C and D

**VDOT**  
 Virginia Department of Transportation

July 2016

U.S. Department of Transportation  
**Federal Highway Administration**

Figure 20

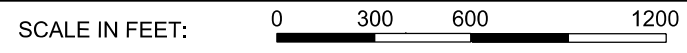



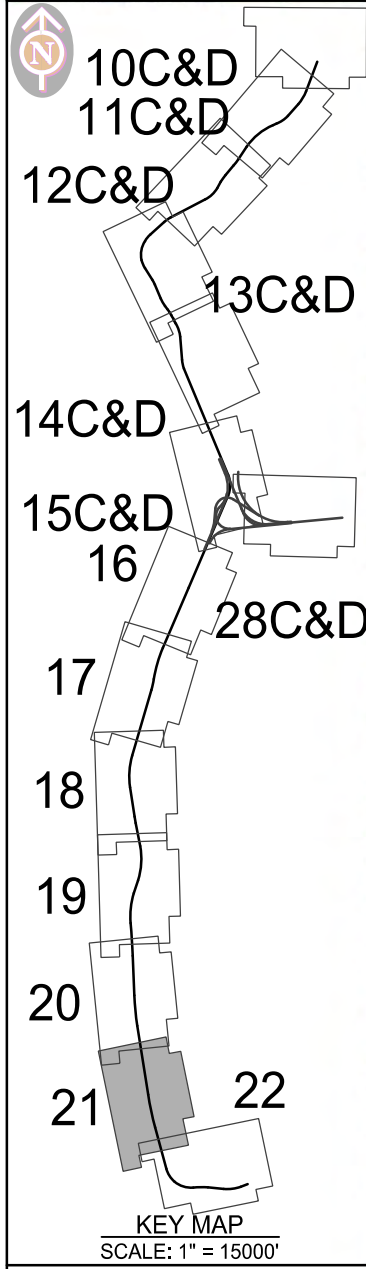
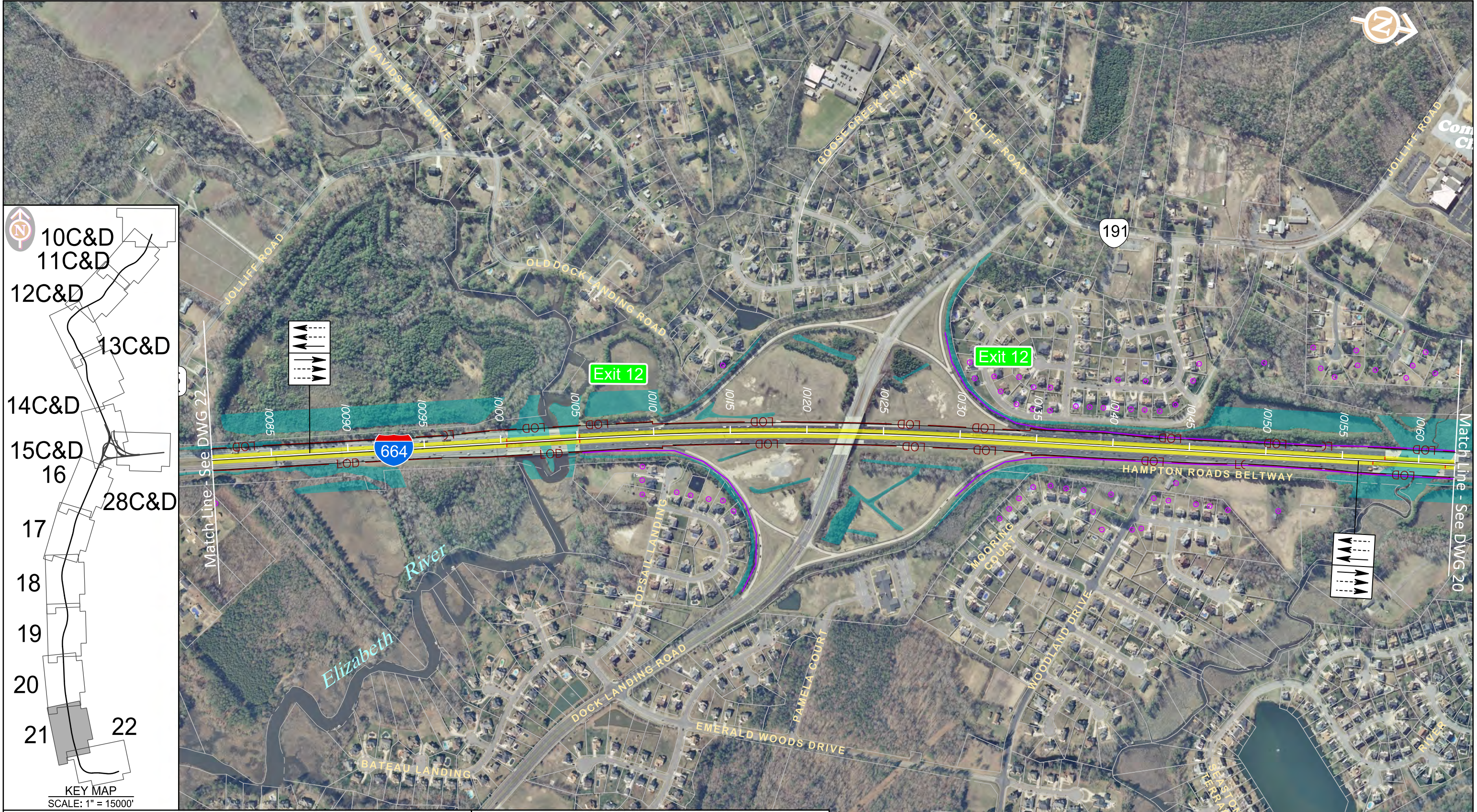

LEGEND	
	PROPOSED ROADWAY IMPROVEMENTS
	PROPOSED STRUCTURES
	PROPOSED LIMIT OF DISTURBANCE
	POTENTIAL DISPLACEMENTS
	WETLANDS / WATERS
	FEDERAL PROPERTIES
	HISTORIC PROPERTIES
	PARKS
	PARCEL BOUNDARY
	PROPOSED NOISE BARRIERS
	IMPACTED NOISE RECEPTORS
	ALTERNATIVES A AND B
	ALTERNATIVE C
	ALTERNATIVE D

**Note:**  
 The information shown is for the purpose of determining cost estimates and environmental impacts and is subject to change during the final design phase. Any reliance upon these plans is made with full understanding of its draft status. Environmental impacts described in the SEIS are based on proposed limits of disturbance.

Aerial Imagery Copyright 2013 Commonwealth of Virginia

**HRCs SEIS**  
 Hampton Roads Crossing Study SEIS

**I-664**  
 Alternatives C and D

**VDOT**  
 Virginia Department of Transportation

July 2016

U.S. Department of Transportation  
**Federal Highway Administration**

Figure 21



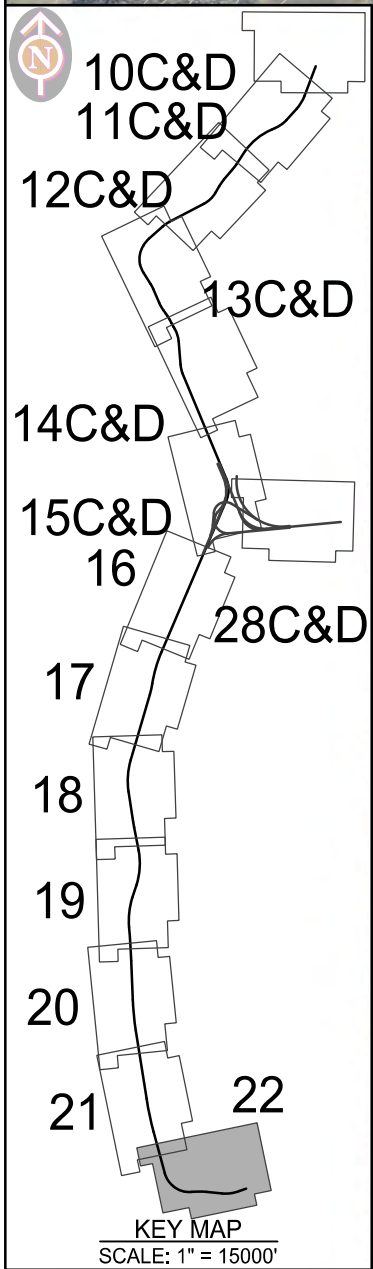
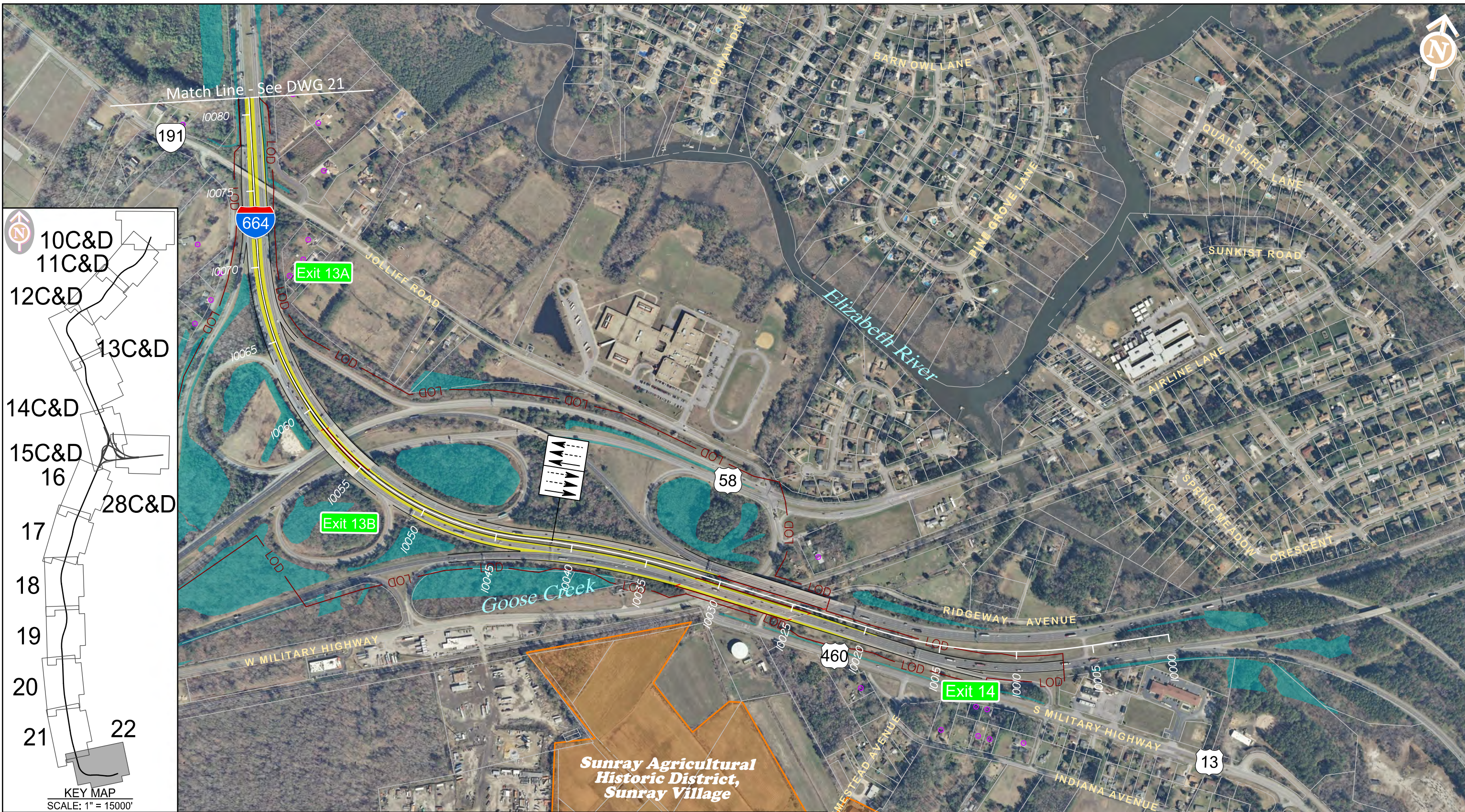

LEGEND	
	PROPOSED ROADWAY IMPROVEMENTS
	PROPOSED STRUCTURES
	PROPOSED LIMIT OF DISTURBANCE
	POTENTIAL DISPLACEMENTS
	WETLANDS / WATERS
	FEDERAL PROPERTIES
	HISTORIC PROPERTIES
	PARKS
	PARCEL BOUNDARY
	PROPOSED NOISE BARRIERS
	IMPACTED NOISE RECEPTORS
	ALTERNATIVE A AND B
	ALTERNATIVE C
	ALTERNATIVE D

**Note:**  
 The information shown is for the purpose of determining cost estimates and environmental impacts and is subject to change during the final design phase. Any reliance upon these plans is made with full understanding of its draft status. Environmental impacts described in the SEIS are based on proposed limits of disturbance.

Aerial Imagery Copyright 2013 Commonwealth of Virginia

**HRCs SEIS**  
 Hampton Roads Crossing Study SEIS

I-664  
 Alternatives C and D

**VDOT**  
 Virginia Department of Transportation

July 2016

U.S. Department of Transportation  
**Federal Highway Administration**

Figure 22

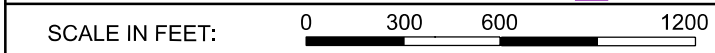

Note:  
To fully account for potential noise impacts, barrier analysis along VA 164 assumed widening to the outside. If this Study Area Corridor is identified as part of a Preferred Alternative, the Final SEIS could document the noise impact of inside widening.

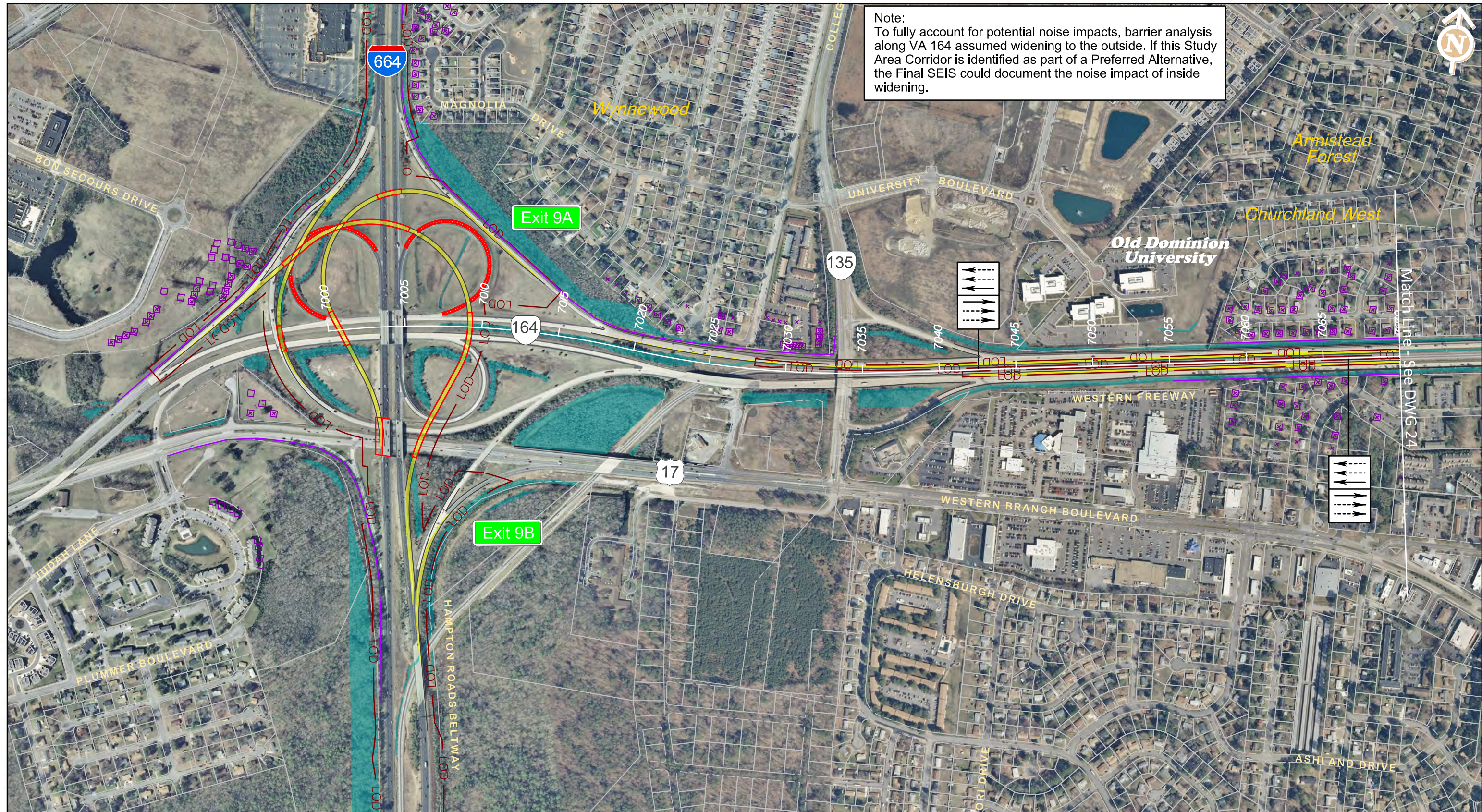

**LEGEND**

	PROPOSED ROADWAY IMPROVEMENTS		HISTORIC PROPERTIES
	PROPOSED STRUCTURES		PARKS
	PROPOSED LIMIT OF DISTURBANCE		PARCEL BOUNDARY
	POTENTIAL DISPLACEMENTS		PROPOSED NOISE BARRIERS
	WETLANDS / WATERS		IMPACTED NOISE RECEPTORS
	FEDERAL PROPERTIES		ALTERNATIVES A AND B
			ALTERNATIVE C
			ALTERNATIVE D

SCALE IN FEET: 0 300 600 1200

**KEY MAP**  
SCALE: 1" = 15000'

Note:  
The information shown is for the purpose of determining cost estimates and environmental impacts and is subject to change during the final design phase. Any reliance upon these plans is made with full understanding of its draft status. Environmental impacts described in the SEIS are based on proposed limits of disturbance.

Aerial Imagery Copyright 2013 Commonwealth of Virginia

**HRCs SEIS**  
Hampton Roads Crossing Study SEIS

**VA 164 ALTERNATIVE B**

**VDOT**  
Virginia Department of Transportation

U.S. Department of Transportation  
**Federal Highway Administration**

July 2016  
Figure 23B

Note:  
To fully account for potential noise impacts, barrier analysis along VA 164 assumed widening to the outside. If this Study Area Corridor is identified as part of a Preferred Alternative, the Final SEIS could document the noise impact of inside widening.

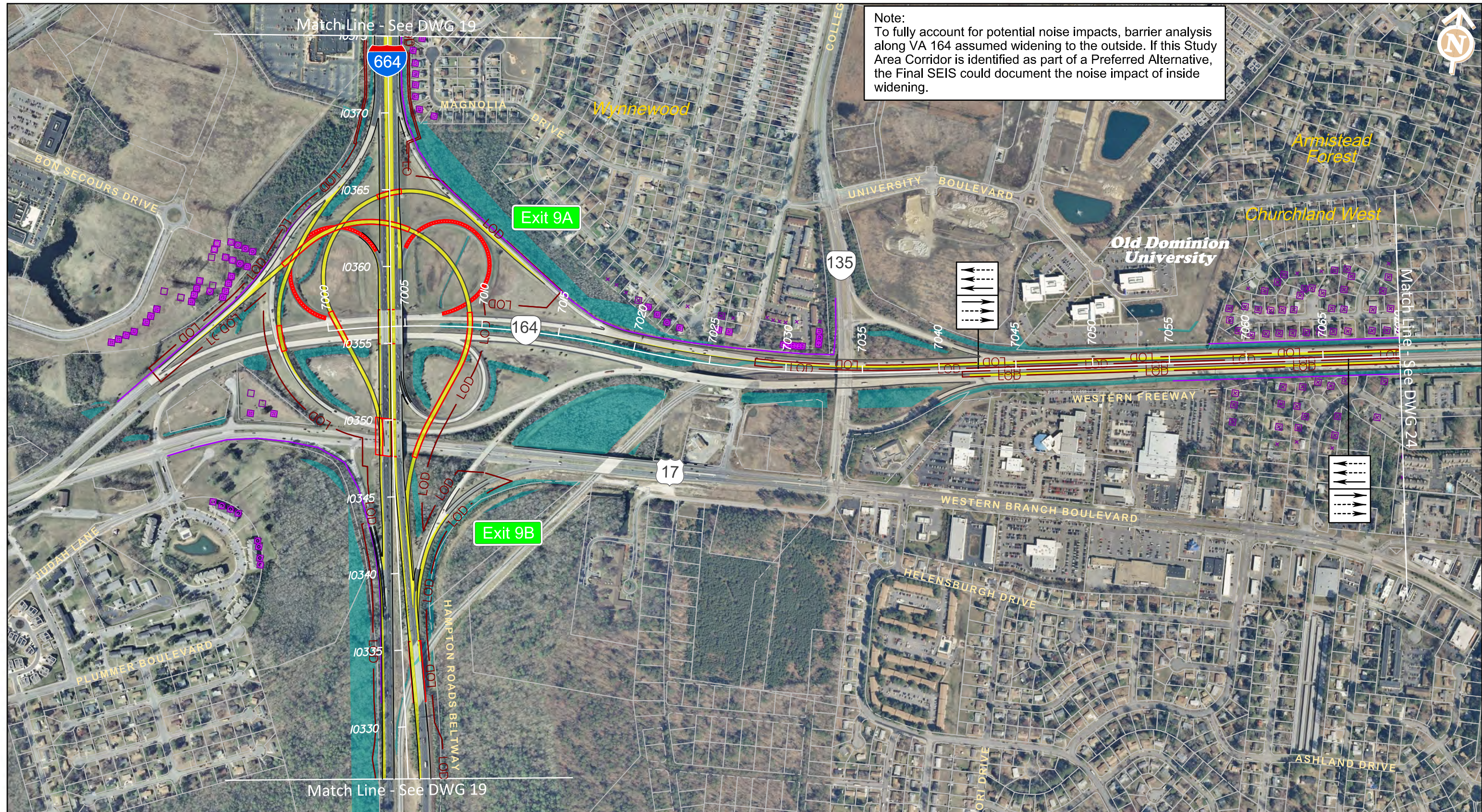

LEGEND	
	PROPOSED ROADWAY IMPROVEMENTS
	PROPOSED STRUCTURES
	PROPOSED LIMIT OF DISTURBANCE
	POTENTIAL DISPLACEMENTS
	WETLANDS / WATERS
	FEDERAL PROPERTIES
	HISTORIC PROPERTIES
	PARKS
	PARCEL BOUNDARY
	PROPOSED NOISE BARRIERS
	IMPACTED NOISE RECEPTORS
	ALTERNATIVES A AND B
	ALTERNATIVE C
	ALTERNATIVE D

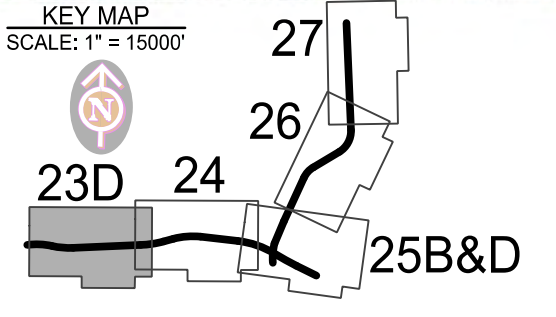
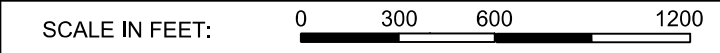

Note:  
The information shown is for the purpose of determining cost estimates and environmental impacts and is subject to change during the final design phase. Any reliance upon these plans is made with full understanding of its draft status. Environmental impacts described in the SEIS are based on proposed limits of disturbance.

Aerial Imagery Copyright 2013 Commonwealth of Virginia

 Hampton Roads Crossing Study SEIS	
<b>VA 164 ALTERNATIVE D</b>	
 Virginia Department of Transportation	July 2016
	Figure 23D

Note:  
To fully account for potential noise impacts, barrier analysis along VA 164 assumed widening to the outside. If this Study Area Corridor is identified as part of a Preferred Alternative, the Final SEIS could document the noise impact of inside widening.

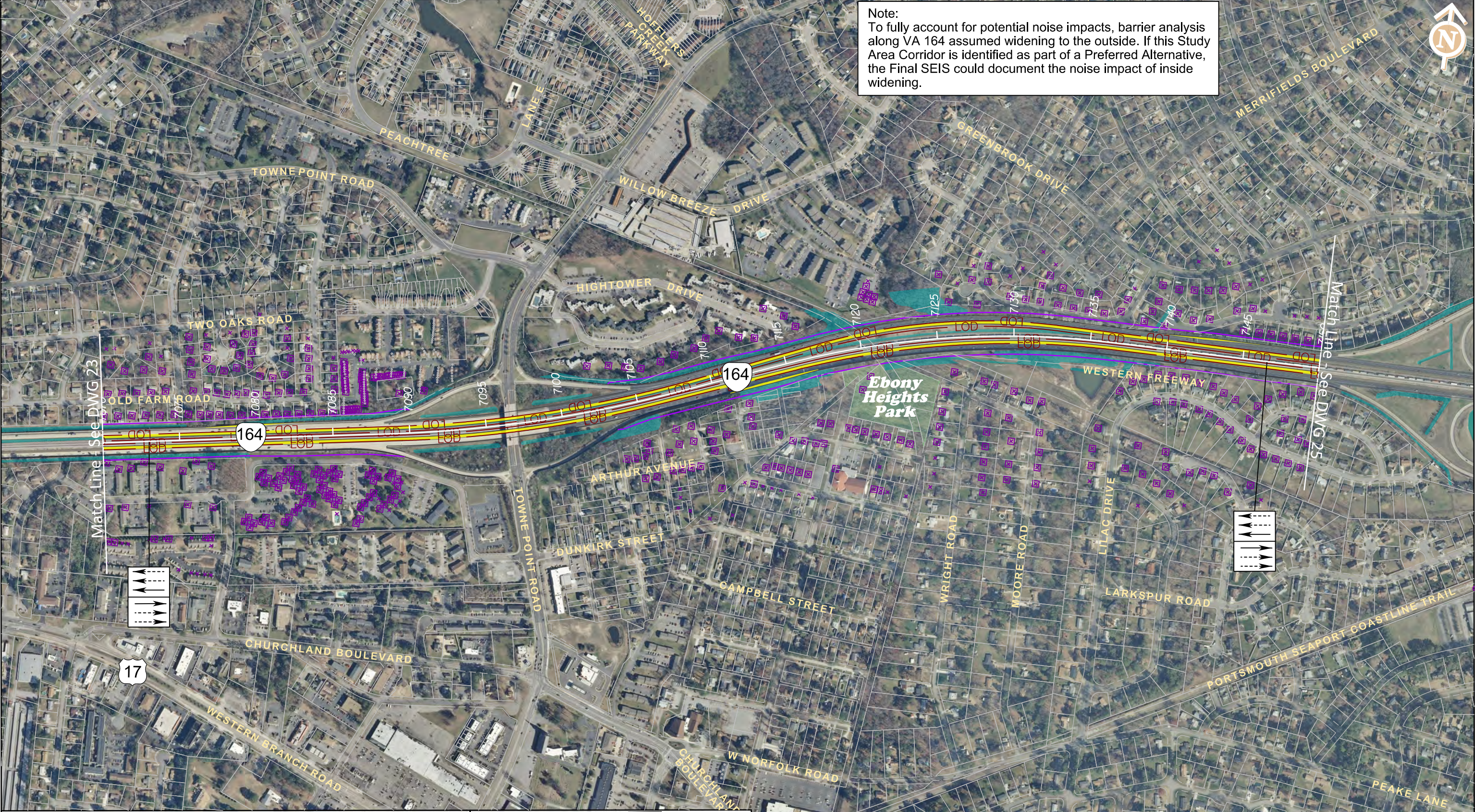

**LEGEND**

	PROPOSED ROADWAY IMPROVEMENTS		HISTORIC PROPERTIES
	PROPOSED STRUCTURES		PARKS
	PROPOSED LIMIT OF DISTURBANCE		PARCEL BOUNDARY
	POTENTIAL DISPLACEMENTS		PROPOSED NOISE BARRIERS
	WETLANDS / WATERS		IMPACTED NOISE RECEPTORS
	FEDERAL PROPERTIES		ALTERNATIVE A AND B
			ALTERNATIVE C
			ALTERNATIVE D

SCALE IN FEET: 0 300 600 1200

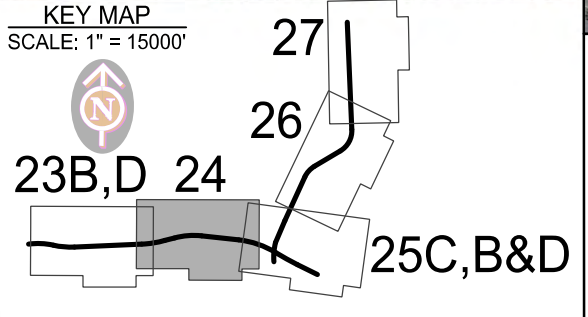

Note:  
The information shown is for the purpose of determining cost estimates and environmental impacts and is subject to change during the final design phase. Any reliance upon these plans is made with full understanding of its draft status. Environmental impacts described in the SEIS are based on proposed limits of disturbance.

Aerial Imagery Copyright 2013 Commonwealth of Virginia

**HRCs SEIS**  
Hampton Roads Crossing Study SEIS

**VA 164 Connector Alternatives B and D**

**VDOT**  
Virginia Department of Transportation

July 2016

U.S. Department of Transportation  
**Federal Highway Administration**

Figure 24B&D

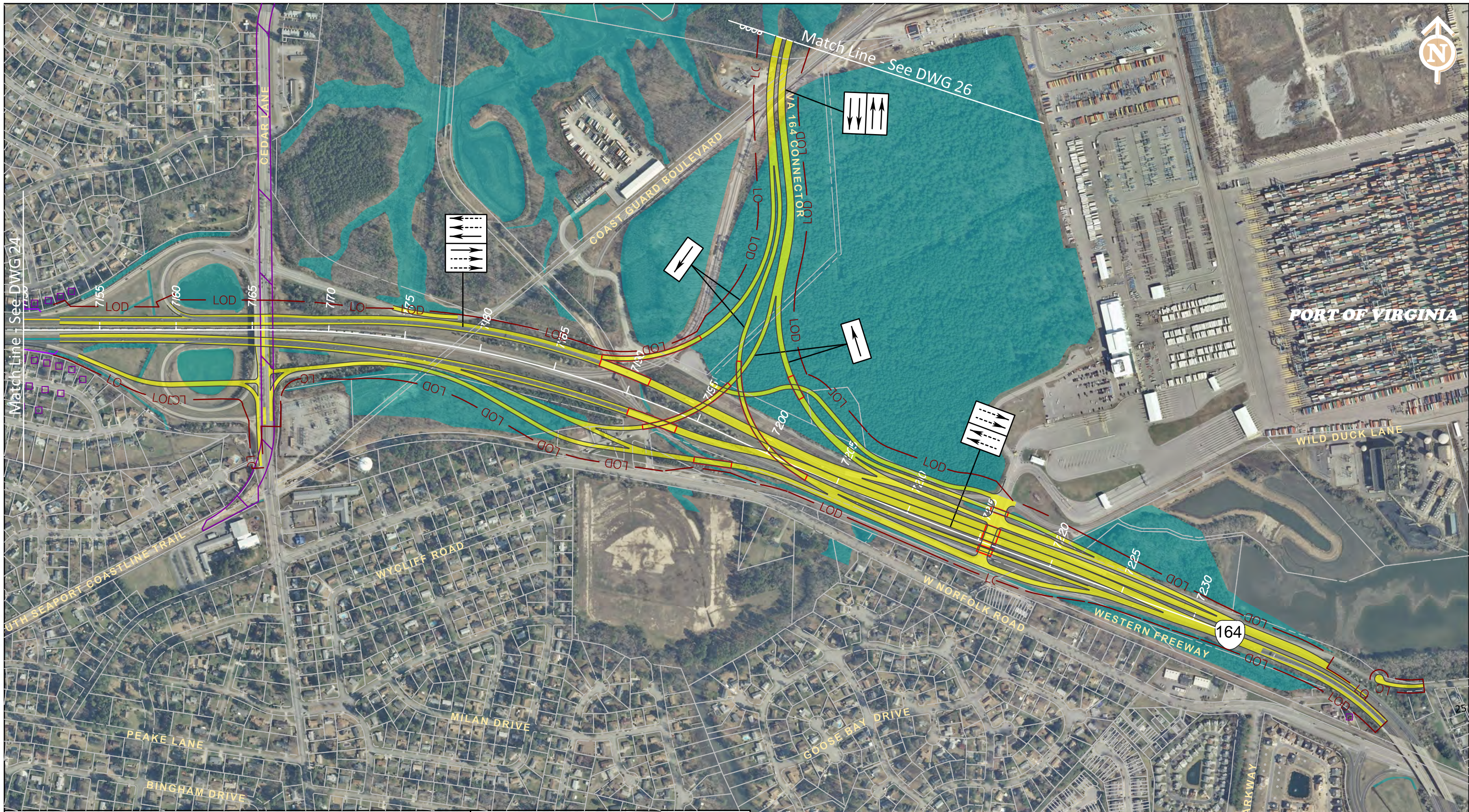

**LEGEND**

	PROPOSED ROADWAY IMPROVEMENTS		HISTORIC PROPERTIES
	PROPOSED STRUCTURES		PARKS
	PROPOSED LIMIT OF DISTURBANCE		PARCEL BOUNDARY
	POTENTIAL DISPLACEMENTS		PROPOSED NOISE BARRIERS
	WETLANDS / WATERS		IMPACTED NOISE RECEPTORS
	FEDERAL PROPERTIES		ALTERNATIVES A AND B
			ALTERNATIVE C
			ALTERNATIVE D

SCALE IN FEET: 0 300 600 1200

**KEY MAP**  
SCALE: 1" = 15000'

**Note:**  
The information shown is for the purpose of determining cost estimates and environmental impacts and is subject to change during the final design phase. Any reliance upon these plans is made with full understanding of its draft status. Environmental impacts described in the SEIS are based on proposed limits of disturbance.

Aerial Imagery Copyright 2013 Commonwealth of Virginia

**HRCs SEIS**  
Hampton Roads Crossing Study SEIS

**VA 164 Connector**  
Alternatives B and D

**VDOT**  
Virginia Department of Transportation

July 2016

U.S. Department of Transportation  
**Federal Highway Administration**

Figure 25B&D

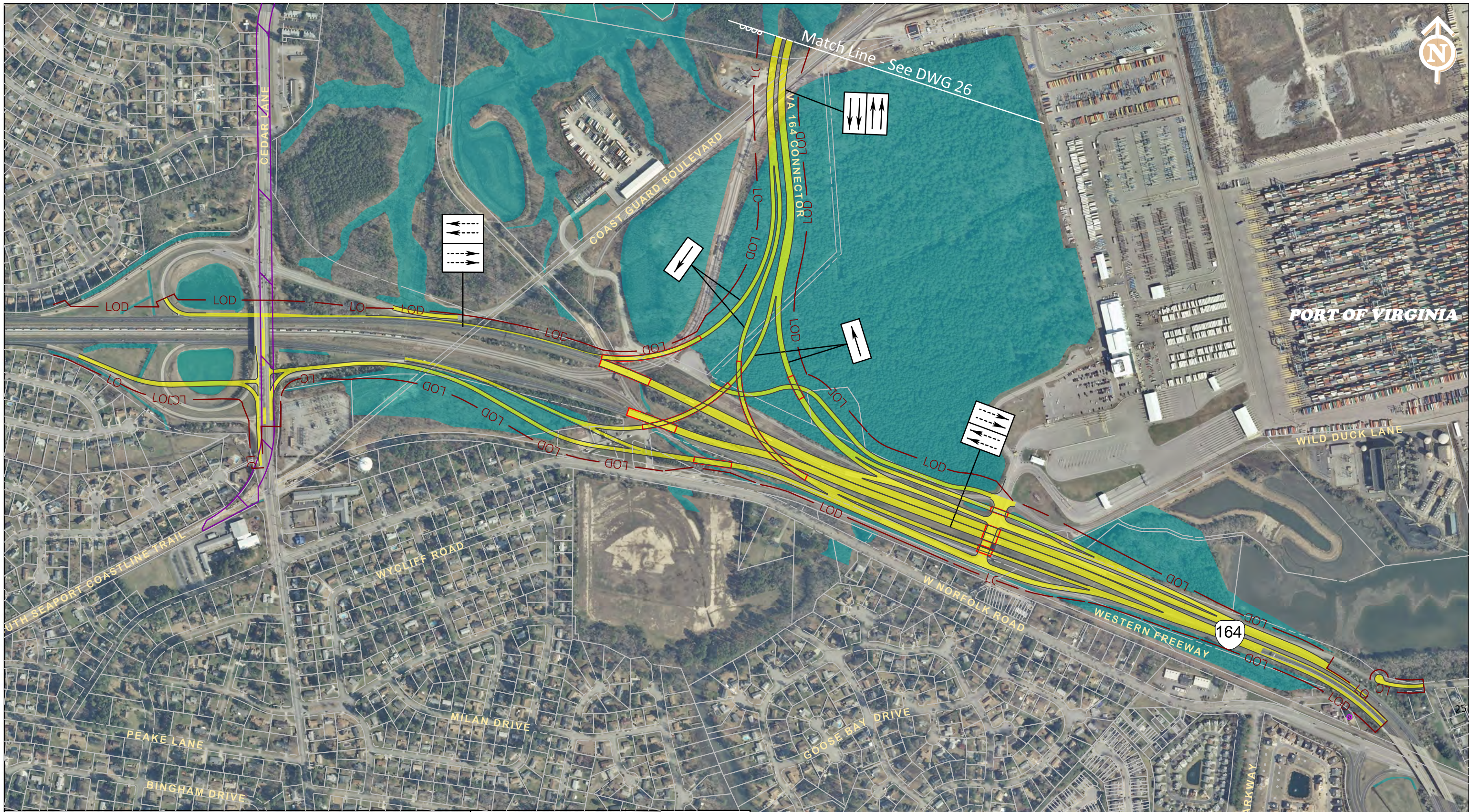

**LEGEND**

	PROPOSED ROADWAY IMPROVEMENTS		HISTORIC PROPERTIES
	PROPOSED STRUCTURES		PARKS
	PROPOSED LIMIT OF DISTURBANCE		PARCEL BOUNDARY
	POTENTIAL DISPLACEMENTS		PROPOSED NOISE BARRIERS
	WETLANDS / WATERS		IMPACTED NOISE RECEPTORS
	FEDERAL PROPERTIES		ALTERNATIVES A AND B
			ALTERNATIVE C
			ALTERNATIVE D

SCALE IN FEET: 0 300 600 1200

**KEY MAP**  
SCALE: 1" = 15000'

**Note:**  
The information shown is for the purpose of determining cost estimates and environmental impacts and is subject to change during the final design phase. Any reliance upon these plans is made with full understanding of its draft status. Environmental impacts described in the SEIS are based on proposed limits of disturbance.

Aerial Imagery Copyright 2013 Commonwealth of Virginia

**HRCs SEIS**  
Hampton Roads Crossing Study SEIS

**VA 164 Connector  
Alternative C**

**VDOT**  
Virginia Department of Transportation

July 2016

U.S. Department of Transportation  
**Federal Highway Administration**

Figure 25C

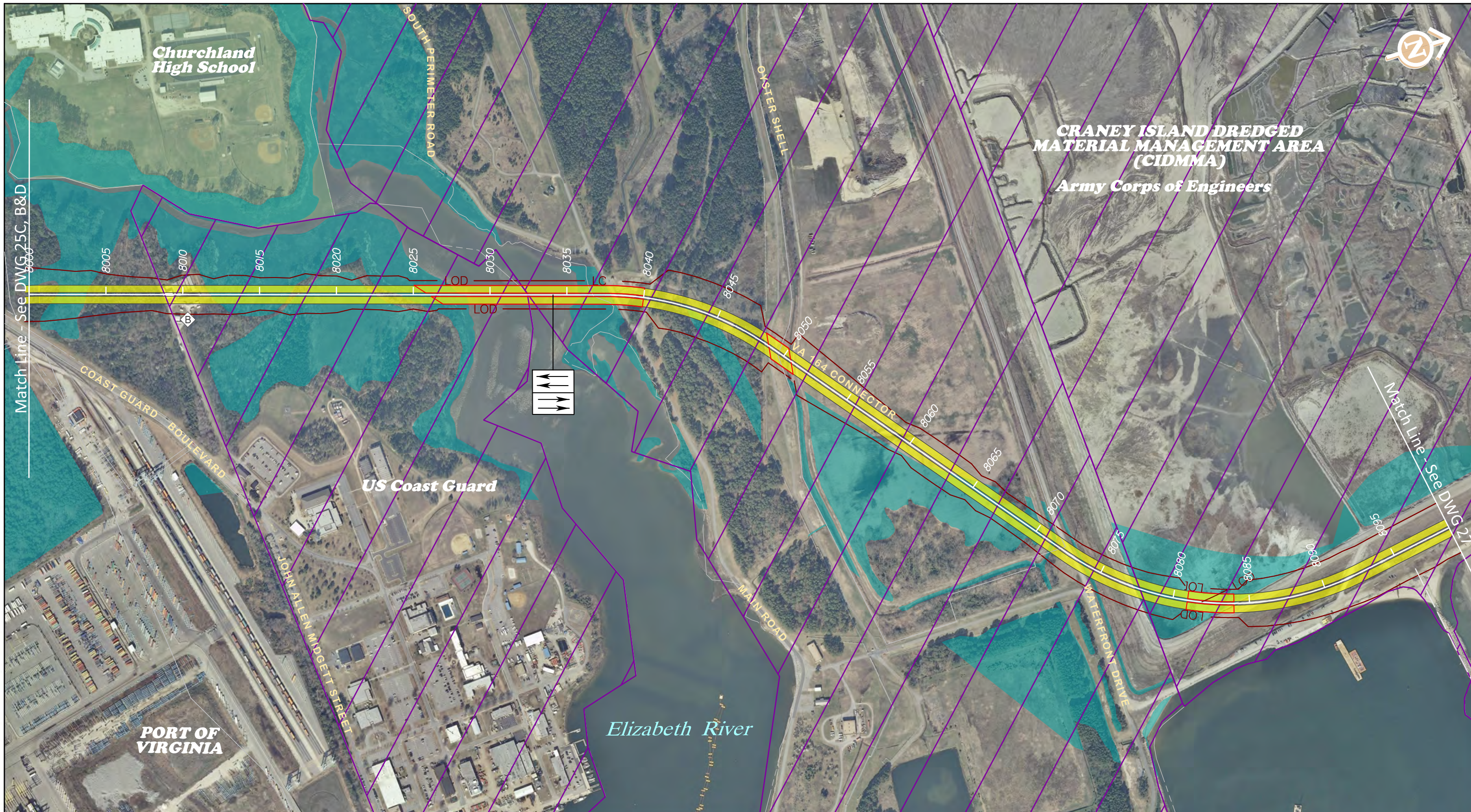

**LEGEND**

	PROPOSED ROADWAY IMPROVEMENTS		HISTORIC PROPERTIES
	PROPOSED STRUCTURES		PARKS
	PROPOSED LIMIT OF DISTURBANCE		PARCEL BOUNDARY
	POTENTIAL DISPLACEMENTS		PROPOSED NOISE BARRIERS
	WETLANDS / WATERS		IMPACTED NOISE RECEPTORS
	FEDERAL PROPERTIES		ALTERNATIVES A AND B
			ALTERNATIVE C
			ALTERNATIVE D

SCALE IN FEET: 0 300 600 1200

**KEY MAP**  
SCALE: 1" = 15000'

27  
26  
23B,D 24  
25C,B&D

**Note:**  
The information shown is for the purpose of determining cost estimates and environmental impacts and is subject to change during the final design phase. Any reliance upon these plans is made with full understanding of its draft status. Environmental impacts described in the SEIS are based on proposed limits of disturbance.

Aerial Imagery Copyright 2013 Commonwealth of Virginia

**HRCs SEIS**  
Hampton Roads Crossing Study SEIS

**VA 164 Connector**

**VDOT**  
Virginia Department of Transportation

July 2016

U.S. Department of Transportation  
**Federal Highway Administration**

Figure 26



**CRANEY ISLAND DREDGED  
MATERIAL MANAGEMENT AREA  
(CIDMMA)**

*Army Corps of Engineers*

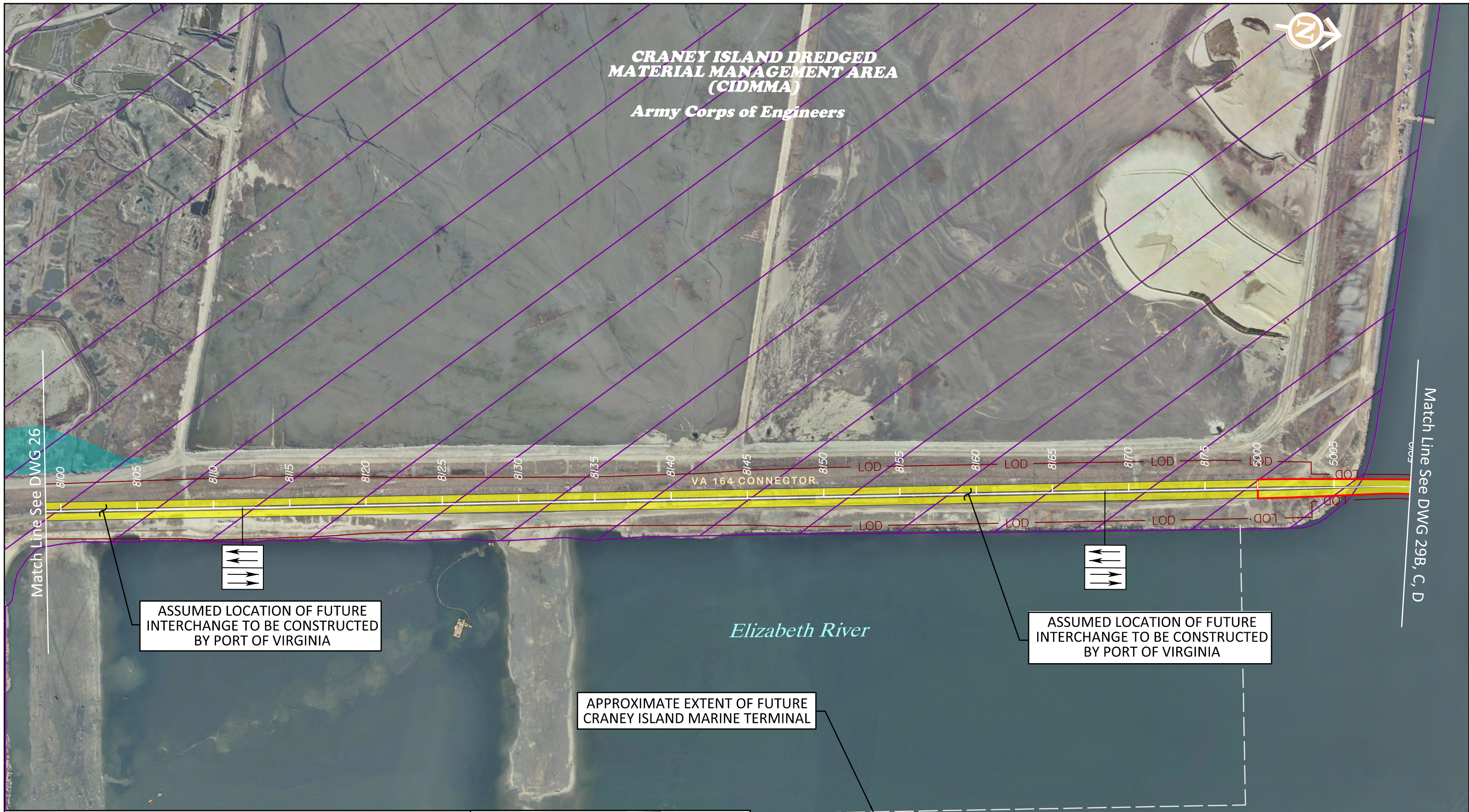

**LEGEND**

	PROPOSED ROADWAY IMPROVEMENTS		HISTORIC PROPERTIES
	PROPOSED STRUCTURES		PARKS
	PROPOSED LIMIT OF DISTURBANCE		PARCEL BOUNDARY
	POTENTIAL DISPLACEMENTS		PROPOSED NOISE BARRIERS
	WETLANDS / WATERS		IMPACTED NOISE RECEPTORS
	FEDERAL PROPERTIES		ALTERNATIVES A AND B
			ALTERNATIVE C
			ALTERNATIVE D

SCALE IN FEET: 0 300 600 1200

**KEY MAP**  
SCALE: 1" = 15000'

**Note:**  
The information shown is for the purpose of determining cost estimates and environmental impacts and is subject to change during the final design phase. Any reliance upon these plans is made with full understanding of its draft status. Environmental impacts described in the SEIS are based on proposed limits of disturbance.

Aerial Imagery Copyright 2013 Commonwealth of Virginia

**HRCS SEIS**  
Hampton Roads Crossing Study SEIS

**VA 164 Connector**

July 2016

U.S. Department of Transportation  
**Federal Highway Administration**

Figure 27



**LEGEND**

	PROPOSED ROADWAY IMPROVEMENTS		HISTORIC PROPERTIES
	PROPOSED STRUCTURES		PARKS
	PROPOSED LIMIT OF DISTURBANCE		PARCEL BOUNDARY
	POTENTIAL DISPLACEMENTS		PROPOSED NOISE BARRIERS
	WETLANDS / WATERS		IMPACTED NOISE RECEPTORS
	FEDERAL PROPERTIES		ALTERNATIVES A AND B
			ALTERNATIVE C
			ALTERNATIVE D

SCALE IN FEET: 0 300 600 1200

**Note:**  
 The information shown is for the purpose of determining cost estimates and environmental impacts and is subject to change during the final design phase. Any reliance upon these plans is made with full understanding of its draft status. Environmental impacts described in the SEIS are based on proposed limits of disturbance.

Aerial Imagery Copyright 2013 Commonwealth of Virginia

**HRCS SEIS**  
 Hampton Roads Crossing Study SEIS

**I-664 Alternative C**

July 2016

U.S. Department of Transportation  
 Federal Highway Administration

Figure 28C

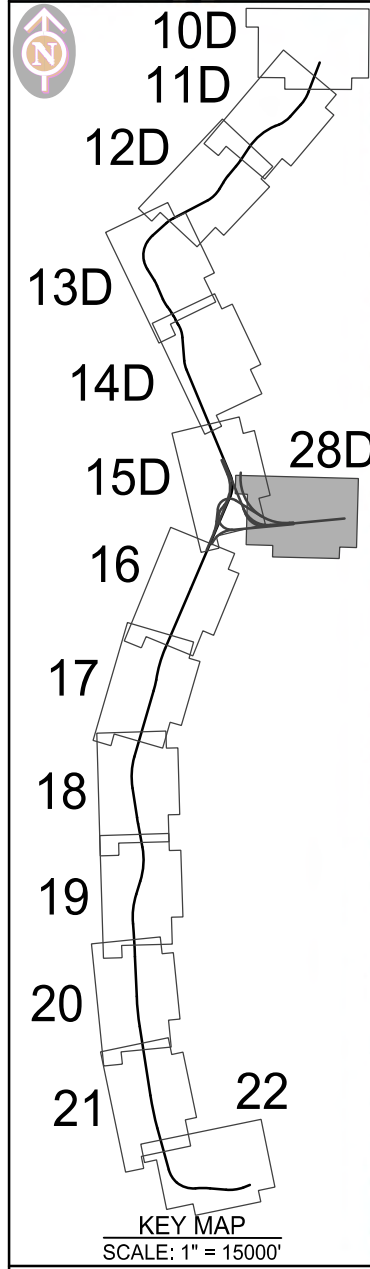

LEGEND	
	PROPOSED ROADWAY IMPROVEMENTS
	PROPOSED STRUCTURES
	PROPOSED LIMIT OF DISTURBANCE
	POTENTIAL DISPLACEMENTS
	WETLANDS / WATERS
	FEDERAL PROPERTIES
	HISTORIC PROPERTIES
	PARKS
	PARCEL BOUNDARY
	PROPOSED NOISE BARRIERS
	IMPACTED NOISE RECEPTORS
	ALTERNATIVES A AND B
	ALTERNATIVE C
	ALTERNATIVE D

**Note:**  
 The information shown is for the purpose of determining cost estimates and environmental impacts and is subject to change during the final design phase. Any reliance upon these plans is made with full understanding of its draft status. Environmental impacts described in the SEIS are based on proposed limits of disturbance.

Aerial Imagery Copyright 2013 Commonwealth of Virginia

**HRCs SEIS**  
 Hampton Roads Crossing Study SEIS

**I-664 Alternative D**

**VDOT**  
 Virginia Department of Transportation

July 2016

U.S. Department of Transportation  
**Federal Highway Administration**

Figure 28D

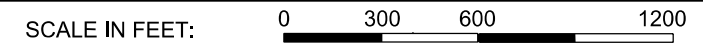



Hampton Roads

I-564 CONNECTOR

Match Line - See DWG 30B

**CRANEY ISLAND DREDGED MATERIAL MANAGEMENT AREA (CIDMMA)**  
Army Corps of Engineers

Match Line - See DWG 27

Elizabeth River

LEGEND	
	PROPOSED ROADWAY IMPROVEMENTS
	PROPOSED STRUCTURES
	PROPOSED LIMIT OF DISTURBANCE
	POTENTIAL DISPLACEMENTS
	WETLANDS / WATERS
	FEDERAL PROPERTIES
	HISTORIC PROPERTIES
	PARKS
	PARCEL BOUNDARY
	PROPOSED NOISE BARRIERS
	IMPACTED NOISE RECEPTORS
	ALTERNATIVES A AND B
	ALTERNATIVE C
	ALTERNATIVE D

SCALE IN FEET: 0 300 600 1200

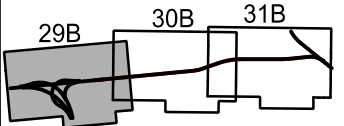

KEY MAP  
SCALE: 1" = 15000'



Note:  
The information shown is for the purpose of determining cost estimates and environmental impacts and is subject to change during the final design phase. Any reliance upon these plans is made with full understanding of its draft status. Environmental impacts described in the SEIS are based on proposed limits of disturbance.

Aerial Imagery Copyright 2013 Commonwealth of Virginia

<b>HRCS SEIS</b> Hampton Roads Crossing Study SEIS	
<b>I-564 Connector Alternative B</b>	
	July 2016
	Figure 29B



Hampton Roads

Elizabeth River



**LEGEND**

	PROPOSED ROADWAY IMPROVEMENTS		HISTORIC PROPERTIES
	PROPOSED STRUCTURES		PARKS
	PROPOSED LIMIT OF DISTURBANCE		PARCEL BOUNDARY
	POTENTIAL DISPLACEMENTS		PROPOSED NOISE BARRIERS
	WETLANDS / WATERS		IMPACTED NOISE RECEPTORS
	FEDERAL PROPERTIES		ALTERNATIVES A AND B
			ALTERNATIVE C
			ALTERNATIVE D

SCALE IN FEET: 0 300 600 1200

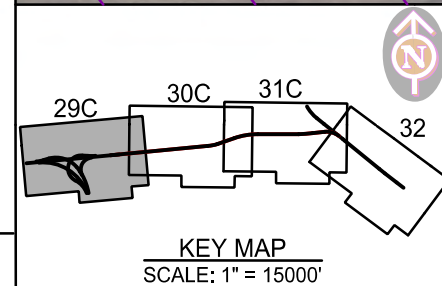

**Note:**  
The information shown is for the purpose of determining cost estimates and environmental impacts and is subject to change during the final design phase. Any reliance upon these plans is made with full understanding of its draft status. Environmental impacts described in the SEIS are based on proposed limits of disturbance.

Aerial Imagery Copyright 2013 Commonwealth of Virginia

**HRCS SEIS**  
Hampton Roads Crossing Study SEIS

**I-564 Connector Alternative C**

**VDOT**  
Virginia Department of Transportation

July 2016

U.S. Department of Transportation  
**Federal Highway Administration**

Figure 29C



Hampton Roads

Match Line - See DWG 28

Match Line - See DWG 30D

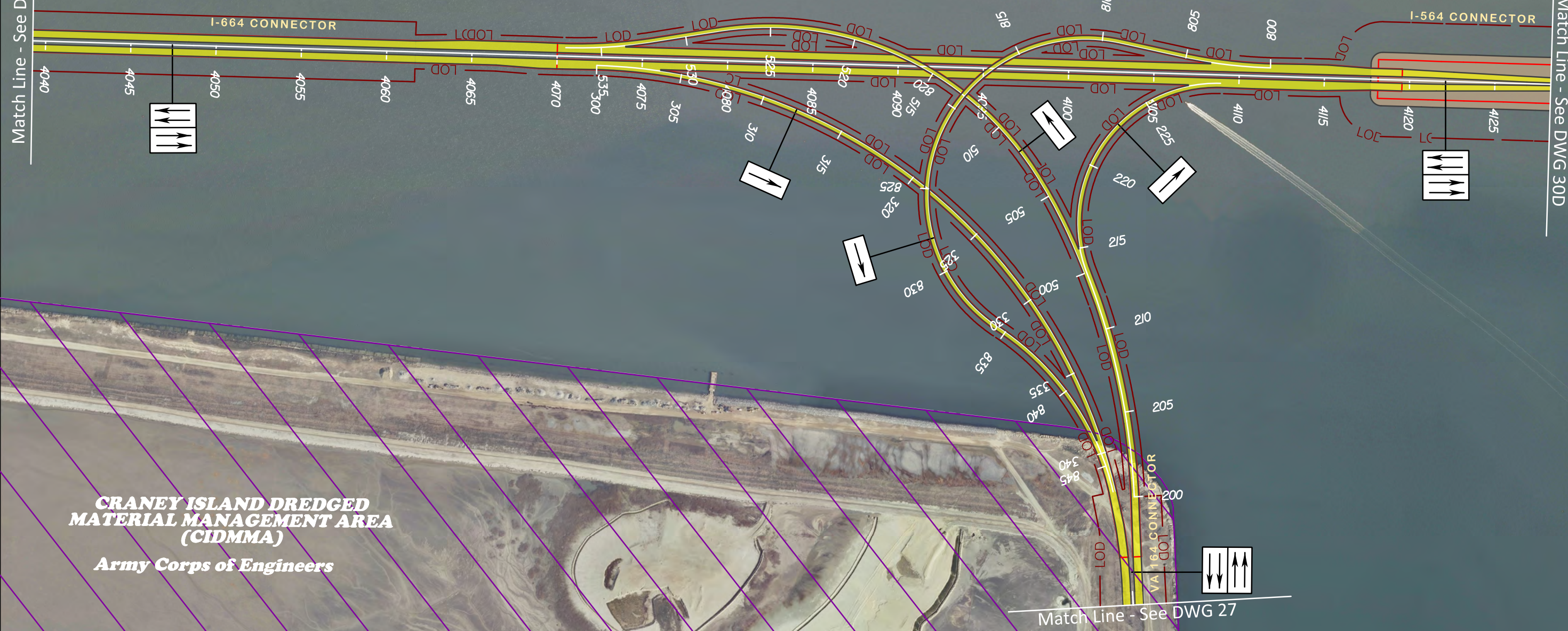

**CRANEY ISLAND DREDGED MATERIAL MANAGEMENT AREA (CIDMMA)**  
 Army Corps of Engineers

Match Line - See DWG 27

Elizabeth River

LEGEND	
	PROPOSED ROADWAY IMPROVEMENTS
	PROPOSED STRUCTURES
	PROPOSED LIMIT OF DISTURBANCE
	POTENTIAL DISPLACEMENTS
	WETLANDS / WATERS
	FEDERAL PROPERTIES
	HISTORIC PROPERTIES
	PARKS
	PARCEL BOUNDARY
	PROPOSED NOISE BARRIERS
	IMPACTED NOISE RECEPTORS
	ALTERNATIVES A AND B
	ALTERNATIVE C
	ALTERNATIVE D

SCALE IN FEET: 0 300 600 1200

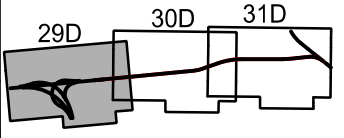

KEY MAP  
 SCALE: 1" = 15000'



Note:  
 The information shown is for the purpose of determining cost estimates and environmental impacts and is subject to change during the final design phase. Any reliance upon these plans is made with full understanding of its draft status. Environmental impacts described in the SEIS are based on proposed limits of disturbance.

Aerial Imagery Copyright 2013 Commonwealth of Virginia

<b>HRCS SEIS</b> Hampton Roads Crossing Study SEIS	
<b>I-564 Connector Alternative D</b>	
	July 2016
	Figure 29D



**LEGEND**

	PROPOSED ROADWAY IMPROVEMENTS		HISTORIC PROPERTIES
	PROPOSED STRUCTURES		PARKS
	PROPOSED LIMIT OF DISTURBANCE		PARCEL BOUNDARY
	POTENTIAL DISPLACEMENTS		PROPOSED NOISE BARRIERS
	WETLANDS / WATERS		IMPACTED NOISE RECEPTORS
	FEDERAL PROPERTIES		ALTERNATIVES A AND B
			ALTERNATIVE C
			ALTERNATIVE D

SCALE IN FEET: 0 300 600 1200

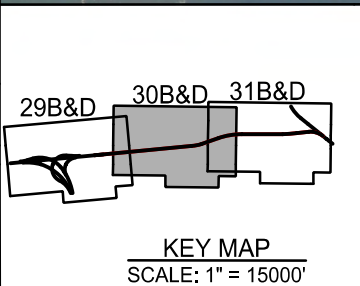

Note:  
The information shown is for the purpose of determining cost estimates and environmental impacts and is subject to change during the final design phase. Any reliance upon these plans is made with full understanding of its draft status. Environmental impacts described in the SEIS are based on proposed limits of disturbance.

Aerial Imagery Copyright 2013 Commonwealth of Virginia

**HRCS SEIS**  
Hampton Roads Crossing Study SEIS

**I-564 Connector**  
Alternatives B and D

**VDOT**  
Virginia Department of Transportation

July 2016

U.S. Department of Transportation  
**Federal Highway Administration**

Figure 30B&D



**LEGEND**

	PROPOSED ROADWAY IMPROVEMENTS		HISTORIC PROPERTIES
	PROPOSED STRUCTURES		PARKS
	PROPOSED LIMIT OF DISTURBANCE		PARCEL BOUNDARY
	POTENTIAL DISPLACEMENTS		PROPOSED NOISE BARRIERS
	WETLANDS / WATERS		IMPACTED NOISE RECEPTORS
	FEDERAL PROPERTIES		ALTERNATIVES A AND B
			ALTERNATIVE C
			ALTERNATIVE D

SCALE IN FEET: 0 300 600 1200

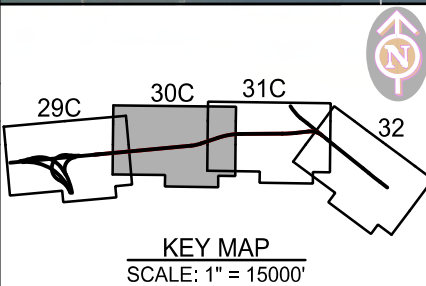

**Note:**  
The information shown is for the purpose of determining cost estimates and environmental impacts and is subject to change during the final design phase. Any reliance upon these plans is made with full understanding of its draft status. Environmental impacts described in the SEIS are based on proposed limits of disturbance.

Aerial Imagery Copyright 2013 Commonwealth of Virginia

**HRCs SEIS**  
Hampton Roads Crossing Study SEIS

**I-564 Connector  
Alternative C**

**VDOT**  
Virginia Department of Transportation

July 2016

U.S. Department of Transportation  
**Federal Highway Administration**

Figure 30C





**LEGEND**

	PROPOSED ROADWAY IMPROVEMENTS		HISTORIC PROPERTIES
	PROPOSED STRUCTURES		PARKS
	PROPOSED LIMIT OF DISTURBANCE		PARCEL BOUNDARY
	POTENTIAL DISPLACEMENTS		PROPOSED NOISE BARRIERS
	WETLANDS / WATERS		IMPACTED NOISE RECEPTORS
	FEDERAL PROPERTIES		ALTERNATIVE A AND B
			ALTERNATIVE C
			ALTERNATIVE D

SCALE IN FEET: 0 300 600 1200

29B&D 30B&D 31B&D

**KEY MAP**  
SCALE: 1" = 15000'

Note:  
The information shown is for the purpose of determining cost estimates and environmental impacts and is subject to change during the final design phase. Any reliance upon these plans is made with full understanding of its draft status. Environmental impacts described in the SEIS are based on proposed limits of disturbance.

Aerial Imagery Copyright 2013 Commonwealth of Virginia

**HRCS SEIS**  
Hampton Roads Crossing Study SEIS

**I-564 Connector Alternatives B and D**

**VDOT** July 2016

U.S. Department of Transportation  
**Federal Highway Administration** Figure 31B&D

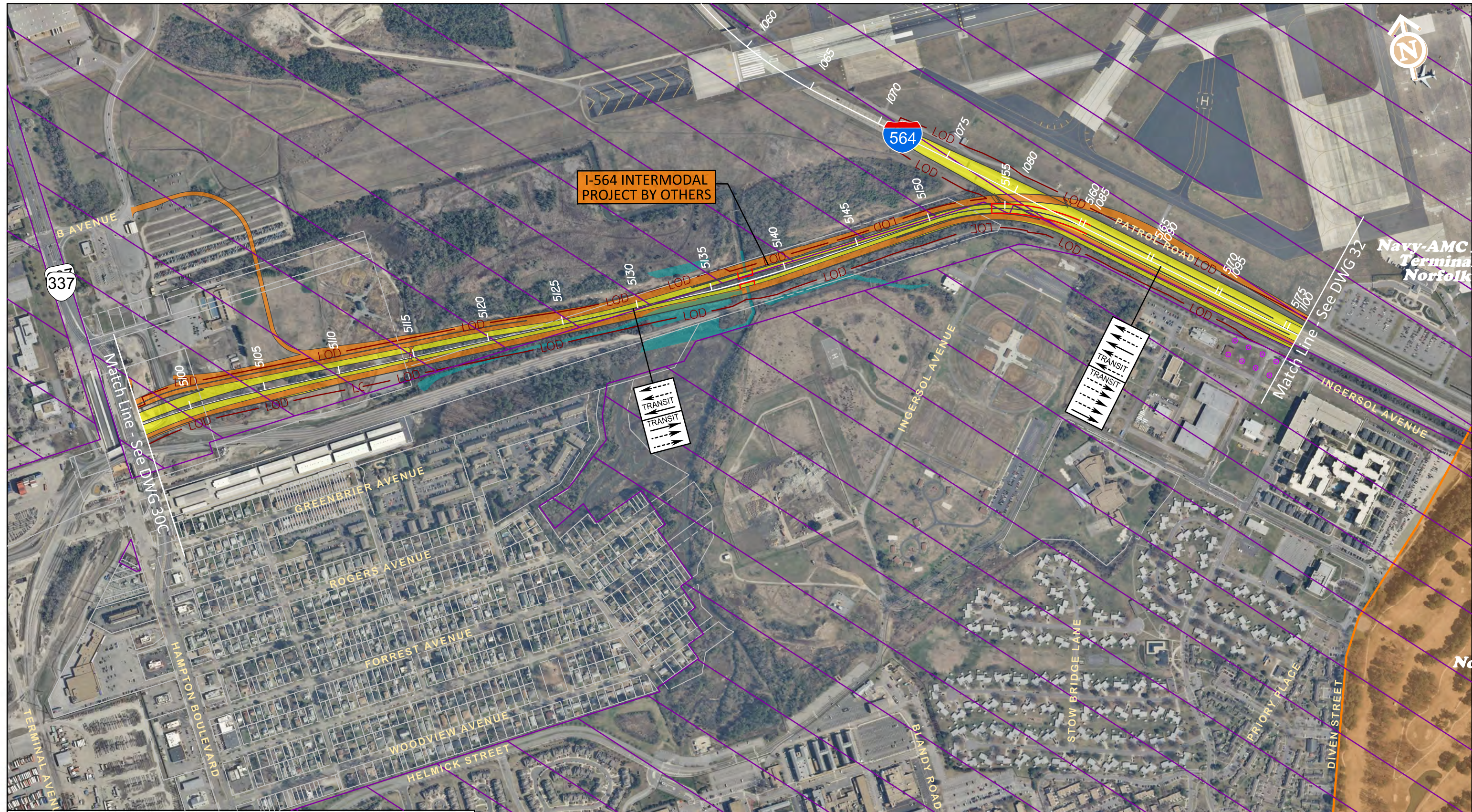

**LEGEND**

	PROPOSED ROADWAY IMPROVEMENTS		HISTORIC PROPERTIES
	PROPOSED STRUCTURES		PARKS
	PROPOSED LIMIT OF DISTURBANCE		PARCEL BOUNDARY
	POTENTIAL DISPLACEMENTS		PROPOSED NOISE BARRIERS
	WETLANDS / WATERS		IMPACTED NOISE RECEPTORS
	FEDERAL PROPERTIES		ALTERNATIVES A AND B
			ALTERNATIVE C
			ALTERNATIVE D

SCALE IN FEET: 0 300 600 1200

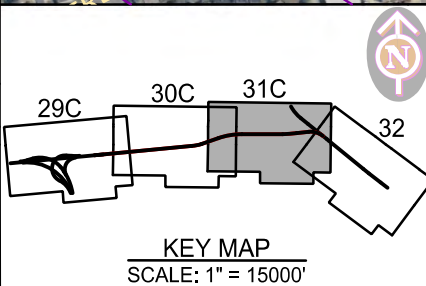

Note:  
The information shown is for the purpose of determining cost estimates and environmental impacts and is subject to change during the final design phase. Any reliance upon these plans is made with full understanding of its draft status. Environmental impacts described in the SEIS are based on proposed limits of disturbance.

Aerial Imagery Copyright 2013 Commonwealth of Virginia

**HRCS SEIS**  
Hampton Roads Crossing Study SEIS

**I-564 Connector  
Alternative C**

**VDOT** July 2016

U.S. Department of Transportation  
**Federal Highway Administration** Figure 31C



**LEGEND**

	PROPOSED ROADWAY IMPROVEMENTS		HISTORIC PROPERTIES
	PROPOSED STRUCTURES		PARKS
	PROPOSED LIMIT OF DISTURBANCE		PARCEL BOUNDARY
	POTENTIAL DISPLACEMENTS		PROPOSED NOISE BARRIERS
	WETLANDS / WATERS		IMPACTED NOISE RECEPTORS
	FEDERAL PROPERTIES		ALTERNATIVES A AND B
			ALTERNATIVE C
			ALTERNATIVE D

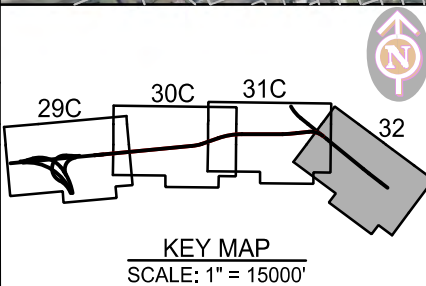
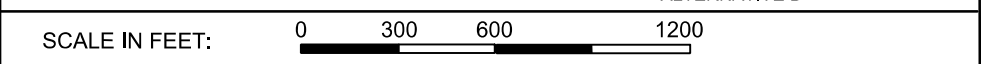

Note:  
The information shown is for the purpose of determining cost estimates and environmental impacts and is subject to change during the final design phase. Any reliance upon these plans is made with full understanding of its draft status. Environmental impacts described in the SEIS are based on proposed limits of disturbance.

Aerial Imagery Copyright 2013 Commonwealth of Virginia

**HRCs SEIS**  
Hampton Roads Crossing Study SEIS

**I-564 Connector  
Alternative C**

**VDOT**  
Virginia Department of Transportation

July 2016

U.S. Department of Transportation  
**Federal Highway Administration**

Figure 32

**APPENDIX B:**  
**COST ESTIMATE METHODOLOGY**

## Engineering Working Technical Memo

**Subject:** Proposed Cost Estimate Approach

**Date:** July 28, 2016

---

This memo details the proposed cost estimate methodology for the Hampton Roads Crossing Study. The study team proposes to use VDOT's Project Cost Estimating System (PCES) and add some additional contingencies for elements that are not clearly defined at this level of design. All cost estimates will be computed using 2016 as the base year and do not include inflation.

The proposed cost estimate elements are described in **Section 1**. **Section 2** describes the proposed cost estimate structure and **Section 3** includes the anticipated cost estimate schedule. All costs are subject to revision based on further refinement of a Preferred Alternative in the Final SEIS.

### 1. COST ESTIMATE ELEMENTS

#### 1.1 Roadway

Preliminary roadway quantities will be calculated using a cost per mile methodology in VDOT's PCES program. It is assumed that 30% of preliminary engineering will be performed by consultants. A 40% contingency will be added to the base construction cost that includes MOT, landscaping, traffic, and tunnel costs.

Other costs to be included in PCES as separate line item costs in the CONST-MISC worksheet which are excluded from the cost per mile calculation:

- 20% of roadway and structures costs (minus tunnel, traffic, and bridges) for roadway maintenance of traffic (MOT). The percentage for MOT will be reduced to 5% of roadway and structures costs for new roadway segments<sup>1</sup> and new roadway segments entirely over water<sup>2</sup>.
- 5% of roadway and structures costs (minus tunnel and traffic) for landscaping, topsoil, and seeding and mulching. Costs for landscaping, topsoil, and seeding and mulching will not be included for new roadway segments entirely over water<sup>2</sup>.
- Milling/planing and overlay – the estimate will include a cost for resurfacing all existing roadways to accommodate MOT work and restriping needs.
  - 25% of overlay quantity will be applied as buildup
- Excessive excavation
- Excessive borrow
- Major drainage structures

---

<sup>1</sup> Segment 13B is considered a new roadway segment (see Table 1).

<sup>2</sup> Segments 5C, 5D, 11C, 11D, 12B, 12C, and 12D are considered new roadway segments entirely over water (see Table 1).

- Concrete Barrier- the estimate will include the total cost for all double-face barrier, single-face barrier, bifurcated barrier, and impact attenuators used in the project.
  - Median Barrier MB-7D – includes all median barrier separating through traffic (with no elevation difference) and all barrier protecting sound walls and retaining walls
  - Median Barrier MB-7F – covers all median barrier required for roadway sections that transition from MB-7D conditions to guardrail conditions
  - Median Barrier MB-8A Type II – includes all median barrier separating through traffic with an elevation difference of no less than 1 foot and no greater than 2 feet
  - Median Barrier MB-8A Type III – consists of all median barrier separating through traffic with an elevation difference of no less than 2 feet and no greater than 3 feet
  - Impact Attenuator Service Type I – includes all crash cushions required to cover blunt guardrail ends within the gore areas and all barrier beginnings that are not transitioning from guardrail
- Guardrail (in excess of 5% of project length) and end treatments - this estimate will include the total cost of all guardrail, end treatments, fixed object attachments, curbing under guardrail and the required curbing backup material.
  - GR-2A – covers all proposed guardrail minus 20 feet for each fixed object attachment
    - This type of guardrail was selected over GR-2 due to reduced deflection from 3 feet to 2 feet and is required when used with MC-3B
  - GR-9 – includes all end treatments placed at the beginning of all stand-alone guardrail sections
  - GR-11 – covers all end treatments placed at the ends of all stand-alone guardrail sections
  - GR-FOA-2, Type I – includes all fixed object attachments for transitions from guardrail to barrier
  - GR-FOA-2, Type II – includes all fixed object attachments for transitions from barrier to guardrail
  - Asphalt Concrete Curb Type MC-3B
  - Asphalt Concrete Backup Material
- Removal of existing guardrail
- Demolition of Existing Pavement
  - It is assumed that existing pavement within the existing road edges can be salvaged
  - Includes removal of any pavement outside the proposed paved shoulder edge along all mainlines
  - Includes removal of existing pavement and replacement with full depth pavement for all existing shoulders
  - It is assumed that **none** of the existing shoulders are full depth pavement and all need to be replaced accordingly
- Noise Barriers – costs for construction of new noise barriers are included in this estimate.
- Retaining Walls – this quantity includes RW-3 concrete quantity, retaining wall excavation and porous backfill.

The percentages for contingencies are subject to change as the project progresses and additional items may be added to this list as the cost estimate is finalized.

## **1.2 Traffic**

Traffic signals, ITS signs, major sign structures, and roadway lighting impacted due to widening will be identified along the corridors and will be included in the TRAFFIC worksheet of the PCES program.

New traffic signals will include mast arms, video detection, and preemption.

Additional traffic items to be estimated include:

- Mile post markers - \$1,000/mile

For new construction along the VA 164 Connector, I-564 Connector, and I-664 Connector the following items will be estimated:

- Guide signs – assumed every 1,300 feet on both sides of the road
- At diamond interchanges, guide signs will be estimated as a lump sum of \$605,000
- At directional 3 leg interchanges, guide signs will be estimated as a lump sum of \$2,005,025
- At directional 4 leg interchanges, guide signs will be estimated as a lump sum of \$2,688,125
- New overhead signing at tunnels will be estimated using the TRAFFIC worksheet in the PCES program.

### **1.3 Bridge Structures**

New bridges, replacement bridges, rehabilitation and bridge widening will be quantified using VDOT's PCES Bridge Program. The costs from the PCES Bridge estimate will then be included in the overall roadway estimate as line items in the BRIDGE worksheet.

The bridge PCES worksheet contains a construction staging drop down that is used to estimate additional costs associated with staged construction; MOT for other situations will be addressed as a miscellaneous bridge item.

The improvements to the structures would consist of widening the existing mainline bridges and completely replacing existing overpass bridges to accommodate the widened mainline of each corridor.

Additionally, some of the existing mainline structures are aging and nearing the end of their useful life cycle. Therefore, any mainline structure affected by the build alternatives with an FHWA sufficiency rating less than 75 but not yet rated structurally deficient, would be included as rehabilitation to the existing bridge. For structures that are currently classified as structurally deficient, the entire structure would be replaced rather than widened. This repair plan would only apply to the bridges being affected by the widening effort within the Study Area Corridors.

A mainline bridge would be affected when the width of the new proposed bridge is greater than the width documented on the structures' as-built plans. An overpass bridge would be affected, and replaced in full, when the new proposed roadway design interferes with the horizontal clearance of at least one substructure unit of the overpass bridge. Vertical clearance, or any hazards around the overpass bridge, were not investigated to determine if the widened roadway would be feasible under the existing conditions. The horizontal clearance was evaluated to determine if the overpass bridge was affected.

### **1.4 Tunnel**

Tunnel costs and existing tunnel modifications will be estimated by the tunnel team and added as a separate line item in the CONST-MISC worksheet.

Dredging costs and earthwork for the tunnel approach islands will be included in the tunnel costs. These costs may be updated in the Final SEIS.

### **1.5 Utilities**

10% of roadway and structures (minus tunnel) costs will be included as a separate line item in the MANUAL worksheet under the RW phase for general utility relocation costs.

Major utilities in the study area were identified by VDOT and assembled into a .kmz file. The study team will review those files and identify additional large utilities such as transmission towers or large water mains that will be impacted by an improvement. Those large utility impacts will be identified and quantified above and beyond the 10% contingency. Costs for water and sewer utilities will be included as a separate line item in the CONST-MISC worksheet. Costs to all other utilities (i.e. power, telephone, gas, etc.) will be included as a separate line item in the MANUAL worksheet under the RW phase. The study team will solicit input from VDOT Hampton Roads District regarding appropriate unit prices to apply to large utilities.

## **1.6 Stormwater Management**

As described below, estimated costs for wet ponds and bioretention facilities will be added as a separate line item in the CONST-MISC worksheet.

To develop a stormwater management estimate, the existing and proposed typical sections are utilized to estimate the amount of impervious area by multiplying the width of new pavement by the distance the typical section is applied along the alignment. It should be noted that Virginia Stormwater Management Program regulations provide a definition for Site that excludes “areas channelward of mean low water in tidal Virginia”; therefore, portions of each alignment within the mean low water level are excluded from the Site for purposes of stormwater management.

All locations are assumed to include type “D” soils (worst case scenario). Based on this, the pounds/year of phosphorus removal required can be estimated for each alternative, on a hydrologic unit code (HUC) basis assuming 50% of the BMP facilities will be wet ponds and the remainder of the BMP facilities will be bioretention facilities. These BMPs are also assumed to split evenly between Level 1 and Level 2 type facilities. Based on this, the amount of impervious area required to send to these facilities to meet the removal requirements can be calculated. Although bioretention facilities are very effective BMP facilities for removing phosphorus in a relative small footprint, high water tables within the project area may preclude the use of bioretention facilities in some areas and wet ponds would be a feasible alternative for these areas.

A typical bioretention facility will receive 0.75 acres of impervious area for treatment. Wet ponds typically receive 2 acres of impervious area for treatment. Therefore, knowing the amount of phosphorus removal required for each alternative, the number of proposed bioretention facilities and wet ponds can be estimated. With an estimate of \$75,000 per bioretention facility and \$250,000 per wet pond, an estimate for the cost of stormwater management for each alternative can be developed. These will be added as a separate line item in the CONST-MISC worksheet.

For the majority of the project, it will be assumed that quantity control requirements can be met when the project outfall discharges into a river or stream which complies with quantity control requirements through the 1% rule (receiving stream is 100 times greater than the site contributing area). If the bioretention facilities currently considered in the planning phase to meet water quality requirements are carried forward into final design, they could be oversized to provide the quantity control requirements (when the outfall does not go into a floodplain or stream).

Assuming the bioretention facility covers 0.04 acres (1650 SF) of land and a wet pond facility covers 0.06 acres (2620 SF), that area can be multiplied by the number of facilities to determine the total footprint of right of way (ROW) needed to accommodate the stormwater management facilities. It will be assumed that the total footprint needed will be located outside of the existing ROW. The proposed ROW impacts will be evenly split among the four land use types that will be used to develop the ROW cost – agricultural,



residential, industrial, and commercial. Costs for right-of-way for stormwater management facilities will be added as a separate line item in the MANUAL worksheet under the RW phase.

It should be noted that although a ROW cost will be included, the facilities have not been located to determine the associated environmental impacts or the specific parcels that would be impacted.

**1.7 Environmental Mitigation**

Because field studies and agency coordination are still underway regarding the specific wetland and stream impacts, a general unit cost per acre for wetlands and linear cost per streams was developed based on recent projects. Wetlands will be estimated at \$35,000 per acre and streams will be estimated at \$500 per impacted linear foot. These will be added as a separate line item in the CONST-MISC worksheet.

A \$500,000 mitigation allowance per adversely affected resource will be included for historic resources and archeological effects. \$2,000,000 will be allocated for contaminated material removal per alternative. This number is a placeholder at this time, as it will not be known in this study the extent of the contaminated material sites for each alternative.

**1.8 Right-of-Way**

Right-of-way impacts will be calculated using GIS property lines, and a cost per acre will be developed based on land use – agricultural, residential, industrial, and commercial. A 40% contingency will be added to the right-of-way estimate. Industrial includes Military and Industrial Land uses, and Commercial includes Commercial, Open Space, and Other Land Uses.

Residential, Industrial, and Commercial costs per square foot were extracted from the RW worksheet of PCES. Institutional is an assumed cost per square foot unit value. Single family home displacement costs utilized the PCES value for a Moderately High Cost Dwelling of \$260,750. Townhome displacement costs utilized the PCES value for an Average Cost Dwelling of \$195,563. Commercial and Industrial displacement costs are estimates based on assessed value. Right-of-way costs do not include any relocation assistance.

Right-of-way costs will be entered in the MANUAL worksheet of the PCES program under the RW phase.

**2. COST ESTIMATE ORGANIZATION**

**2.1 Individual Roadway Segment Cost Estimates**

Roadway PCES Estimates will be prepared for each of the 22 alignment segments as shown in **Table 1:**

**Table 1: Individual Roadway PCES Segments**

Segment Number	Roadway Section Description
1	I-664 from US 58 (Bowers Hill) to I-264
2	I-664 from VA 164 to US 58 (Bowers Hill)
3	I-664 and VA 164 Interchange
4	I-664 from I-664 Connector to VA 164
5C	I-664 from Terminal Avenue Interchange to I-664 Connector. Proposed design includes 8 lanes plus 2 transit only lanes.
5D	I-664 from Terminal Avenue Interchange to I-664 Connector. Proposed design includes 8 lanes.
6C	Terminal Avenue Interchange. Proposed interchange to connect with I-664 design that includes 8 lanes plus 2 transit only lanes.

<b>Segment Number</b>	<b>Roadway Section Description</b>
6D	Terminal Avenue Interchange. Proposed interchange to connect with I-664 design that includes 8 lanes.
7C	I-664 from I-64 to Terminal Avenue Interchange. Proposed design includes 8 lanes plus 2 transit only lanes.
7D	I-664 from I-64 to Terminal Avenue Interchange. Proposed design includes 8 lanes.
8	I-64 north of HRBT
9	I-64 from HRBT to I-564
10B/D	I-564 and I-564 Connector. Proposed design includes 8 lanes.
10C	I-564 and I-564 Connector. Proposed design includes 8 lanes plus 2 transit only lanes.
11C	I-664 Connector including I-664 interchange. Proposed interchange to connect with I-664 design that includes 8 lanes plus 2 transit only lanes.
11D	I-664 Connector including I-664 interchange. Proposed interchange to connect with I-664 design that includes 8 lanes.
12B	I-564 Connector and VA 164 Connector Interchange
12C	I-564 Connector, I-664 Connector, and VA 164 Connector Interchange. Proposed interchange to connect with I-564 design that includes 4 lanes plus 2 transit only lanes.
12D	I-564 Connector, I-664 Connector, and VA 164 Connector Interchange. Proposed interchange to connect with I-564 design that includes 4 lanes.
13A	VA 164 Connector including interchange with VA 164 up to northernmost future port interchange.
13B	VA 164 Connector from northernmost future port interchange up to I-564 Connector.
14	VA 164
<b>22</b>	<b><i>Separate PCES files</i></b>

Bridge costs from the Structures PCES program will be input into the appropriate alignment segment PCES file.

## 2.2 Alternative Cost Estimates

The alignment segment PCES files will then be summarized in a separate estimate for each Alternative as shown in **Tables 2 through 5** below.

**Table 2: Alternative A**

Section Number	Roadway Section Description
8	I-64 north of HRBT
9	I-64 from HRBT to I-564

**Table 3: Alternative B**

Section Number	Roadway Section Description
8	I-64 north of HRBT
9	I-64 from HRBT to I-564
10B/D	I-564 and I-564 Connector. Proposed design includes 8 lanes.
12B	I-564 Connector and VA 164 Connector Interchange.
13A	VA 164 Connector including interchange with VA 164 up to northernmost future port interchange.
13B	VA 164 Connector from northernmost future port interchange up to I-564 Connector.
14	VA 164

**Table 4: Alternative C**

Section Number	Roadway Section Description
1	I-664 from US 58 (Bowers Hill) to I-264
2	I-664 from VA 164 to US 58 (Bowers Hill)
3	I-664 and VA 164 Interchange
4	I-664 from I-664 Connector to VA 164
5C	I-664 from Terminal Avenue Interchange to I-664 Connector. Proposed design includes 8 lanes plus 2 transit only lanes.
6C	Terminal Avenue Interchange. Proposed interchange to connect with I-664 design that includes 8 lanes plus 2 transit only lanes.
7C	I-664 from I-64 to Terminal Avenue Interchange. Proposed design includes 8 lanes plus 2 transit only lanes.
10C	I-564 and I-564 Connector. Proposed design includes 8 lanes plus 2 transit only lanes.
11C	I-664 Connector including I-664 interchange. Proposed interchange to connect with I-664 design that includes 8 lanes plus 2 transit only lanes
12C	I-564 Connector, I-664 Connector, and VA 164 Connector Interchange. Proposed interchange to connect with I-564 design that includes 4 lanes plus 2 transit only lanes.
13A	VA 164 Connector including interchange with VA 164 up to northernmost future port interchange.
13B	VA 164 Connector from northernmost future port interchange up to I-564 Connector.

**Table 5: Alternative D**

<b>Section Number</b>	<b>Roadway Section Description</b>
1	I-664 from US 58 (Bowers Hill) to I-264
2	I-664 from VA 164 to US 58 (Bowers Hill)
3	I-664 and VA 164 Interchange
4	I-664 from I-664 Connector to VA 164
5D	I-664 from Terminal Avenue Interchange to I-664 Connector. Proposed design includes 8 lanes.
6D	Terminal Avenue Interchange. Proposed interchange to connect with I-664 design that includes 8 lanes.
7D	I-664 from I-64 to Terminal Avenue Interchange. Proposed design includes 8 lanes.
8	I-64 north of HRBT
9	I-64 from HRBT to I-564
10B/D	I-564 and I-564 Connector. Proposed design includes 8 lanes.
11D	I-664 Connector including I-664 interchange. Proposed interchange to connect with I-664 design that includes 8 lanes.
12D	I-564 Connector, I-664 Connector, and VA 164 Connector Interchange. Proposed interchange to connect with I-564 design that includes 4 lanes.
13A	VA 164 Connector including interchange with VA 164 up to northernmost future port interchange.
13B	VA 164 Connector from northernmost future port interchange up to I-564 Connector.
14	VA 164

**3. SCHEDULE**

The anticipated schedule is as follows:

**Table 6: Cost Estimate Schedule**

	<b>Estimated Delivery Date</b>
Begin Pulling cost quantities	April 1, 2016
Preliminary Cost Estimate Draft to VDOT	May 9, 2016
Comments Back from VDOT	May 20, 2016
Preliminary Cost Estimate	June 3, 2016

**APPENDIX C:  
COST ESTIMATES**

Alternative	Construction Estimate	Preliminary Engineering Estimate	Right-of-Way & Utilities Estimate	Estimated Total Cost
A	\$ 2,927,164,600.00	\$ 237,598,800.00	\$ 68,779,200.00	\$ 3,233,542,600.00
B	\$ 5,837,993,000.00	\$ 487,353,700.00	\$ 224,873,500.00	\$ 6,550,220,200.00
C	\$ 11,128,613,800.00	\$ 857,852,800.00	\$ 466,277,500.00	\$ 12,452,744,100.00
D	\$ 10,573,067,600.00	\$ 809,303,300.00	\$ 465,952,300.00	\$ 11,848,323,200.00

**Alternative A**

<b>Segment</b>	<b>Construction Estimate</b>	<b>Preliminary Engineering Estimate</b>	<b>Right-of-Way &amp; Utilities Estimate</b>	<b>Estimated Total Cost</b>
8	\$ 54,629,062.00	\$ 4,958,083.00	\$ 4,426,957.00	\$ 64,014,102.00
9	\$ 2,870,535,564.00	\$ 232,640,704.00	\$ 64,352,205.00	\$ 3,167,528,473.00
	\$ 2,000,000.00	ALLOWANCE FOR CONTAMINATED MATERIAL REMOVAL		
<b>TOTAL</b>	<b>\$ 2,927,164,600.00</b>	<b>\$ 237,598,800.00</b>	<b>\$ 68,779,200.00</b>	<b>\$ 3,233,542,600.00</b>

**Alternative B**

<b>Segment</b>	<b>Construction Estimate</b>	<b>Preliminary Engineering Estimate</b>	<b>Right-of-Way &amp; Utilities Estimate</b>	<b>Estimated Total Cost</b>
8	\$ 54,629,062.00	\$ 4,958,083.00	\$ 4,426,957.00	\$ 64,014,102.00
9	\$ 2,870,535,564.00	\$ 232,640,704.00	\$ 64,352,205.00	\$ 3,167,528,473.00
10B/D	\$ 2,317,457,349.00	\$ 212,732,318.00	\$ 29,974,800.00	\$ 2,560,164,467.00
12B	\$ 201,721,357.00	\$ 6,609,239.00	\$ 21,101,197.00	\$ 229,431,793.00
13A	\$ 259,080,175.00	\$ 18,833,859.00	\$ 31,139,598.00	\$ 309,053,632.00
13B	\$ 28,476,225.00	\$ 2,619,813.00	\$ 67,524,069.00	\$ 98,620,107.00
14	\$ 104,093,232.00	\$ 8,959,721.00	\$ 6,354,718.00	\$ 119,407,671.00
	\$ 2,000,000.00	ALLOWANCE FOR CONTAMINATED MATERIAL REMOVAL		
<b>TOTAL</b>	<b>\$ 5,837,993,000.00</b>	<b>\$ 487,353,700.00</b>	<b>\$ 224,873,500.00</b>	<b>\$ 6,550,220,200.00</b>



**Alternative C**

<b>Segment</b>	<b>Construction Estimate</b>	<b>Preliminary Engineering Estimate</b>	<b>Right-of-Way &amp; Utilities Estimate</b>	<b>Estimated Total Cost</b>
1	\$ 45,989,670.00	\$ 4,027,384.00	\$ 3,492,315.00	\$ 53,509,369.00
2	\$ 168,229,912.00	\$ 14,130,200.00	\$ 12,671,335.00	\$ 195,031,447.00
3	\$ 107,443,742.00	\$ 8,323,689.00	\$ 7,407,544.00	\$ 123,174,975.00
4	\$ 368,697,088.00	\$ 16,771,219.00	\$ 38,069,282.00	\$ 423,537,589.00
5C	\$ 3,539,420,549.00	\$ 325,626,691.00	\$ 6,420,839.00	\$ 3,871,468,079.00
6C	\$ 312,560,648.00	\$ 11,924,751.00	\$ 31,514,132.00	\$ 355,999,531.00
7C	\$ 429,926,467.00	\$ 31,742,267.00	\$ 49,449,811.00	\$ 511,118,545.00
10C	\$ 4,015,591,421.00	\$ 367,398,736.00	\$ 49,979,087.00	\$ 4,432,969,244.00
11C	\$ 1,339,225,237.00	\$ 40,244,145.00	\$ 119,761,800.00	\$ 1,499,231,182.00
12C	\$ 511,972,714.00	\$ 16,210,040.00	\$ 48,847,700.00	\$ 577,030,454.00
13A	\$ 259,080,175.00	\$ 18,833,859.00	\$ 31,139,598.00	\$ 309,053,632.00
13B	\$ 28,476,225.00	\$ 2,619,813.00	\$ 67,524,069.00	\$ 98,620,107.00
	\$ 2,000,000.00	ALLOWANCE FOR CONTAMINATED MATERIAL REMOVAL		
<b>TOTAL</b>	<b>\$ 11,128,613,800.00</b>	<b>\$ 857,852,800.00</b>	<b>\$ 466,277,500.00</b>	<b>\$ 12,452,744,100.00</b>

**Alternative D**

<b>Segment</b>	<b>Construction Estimate</b>	<b>Preliminary Engineering Estimate</b>	<b>Right-of-Way &amp; Utilities Estimate</b>	<b>Estimated Total Cost</b>
1	\$ 45,989,670.00	\$ 4,027,384.00	\$ 3,492,315.00	\$ 53,509,369.00
2	\$ 168,229,912.00	\$ 14,130,200.00	\$ 12,671,335.00	\$ 195,031,447.00
3	\$ 107,443,742.00	\$ 8,323,689.00	\$ 7,407,544.00	\$ 123,174,975.00
4	\$ 368,697,088.00	\$ 16,771,219.00	\$ 38,069,282.00	\$ 423,537,589.00
5D	\$ 2,245,544,255.00	\$ 206,590,072.00	\$ 6,227,551.00	\$ 2,458,361,878.00
6D	\$ 249,424,681.00	\$ 9,258,682.00	\$ 25,872,323.00	\$ 284,555,686.00
7D	\$ 364,812,625.00	\$ 26,492,455.00	\$ 41,484,492.00	\$ 432,789,572.00
8	\$ 54,629,062.00	\$ 4,958,083.00	\$ 4,426,957.00	\$ 64,014,102.00
9	\$ 2,870,535,564.00	\$ 232,640,704.00	\$ 64,352,205.00	\$ 3,167,528,473.00
10B/D	\$ 2,317,457,349.00	\$ 212,732,318.00	\$ 29,974,800.00	\$ 2,560,164,467.00
11D	\$ 930,848,401.00	\$ 28,324,098.00	\$ 83,183,700.00	\$ 1,042,356,199.00
12D	\$ 455,805,660.00	\$ 14,640,987.00	\$ 43,771,448.00	\$ 514,218,095.00
13A	\$ 259,080,175.00	\$ 18,833,859.00	\$ 31,139,598.00	\$ 309,053,632.00
13B	\$ 28,476,225.00	\$ 2,619,813.00	\$ 67,524,069.00	\$ 98,620,107.00
14	\$ 104,093,232.00	\$ 8,959,721.00	\$ 6,354,718.00	\$ 119,407,671.00
	\$ 2,000,000.00	ALLOWANCE FOR CONTAMINATED MATERIAL REMOVAL		
<b>TOTAL</b>	<b>\$ 10,573,067,600.00</b>	<b>\$ 809,303,300.00</b>	<b>\$ 465,952,300.00</b>	<b>\$ 11,848,323,200.00</b>

Segment	Construction Estimate	Preliminary Engineering Estimate	Right-of-Way & Utilities Estimate	Estimated Total Cost
1	\$ 45,989,670.00	\$ 4,027,384.00	\$ 3,492,315.00	\$ 53,509,369.00
2	\$ 168,229,912.00	\$ 14,130,200.00	\$ 12,671,335.00	\$ 195,031,447.00
3	\$ 107,443,742.00	\$ 8,323,689.00	\$ 7,407,544.00	\$ 123,174,975.00
4	\$ 368,697,088.00	\$ 16,771,219.00	\$ 38,069,282.00	\$ 423,537,589.00
5C	\$ 3,539,420,549.00	\$ 325,626,691.00	\$ 6,420,839.00	\$ 3,871,468,079.00
5D	\$ 2,245,544,255.00	\$ 206,590,072.00	\$ 6,227,551.00	\$ 2,458,361,878.00
6C	\$ 312,560,648.00	\$ 11,924,751.00	\$ 31,514,132.00	\$ 355,999,531.00
6D	\$ 249,424,681.00	\$ 9,258,682.00	\$ 25,872,323.00	\$ 284,555,686.00
7C	\$ 429,926,467.00	\$ 31,742,267.00	\$ 49,449,811.00	\$ 511,118,545.00
7D	\$ 364,812,625.00	\$ 26,492,455.00	\$ 41,484,492.00	\$ 432,789,572.00
8	\$ 54,629,062.00	\$ 4,958,083.00	\$ 4,426,957.00	\$ 64,014,102.00
9	\$ 2,870,535,564.00	\$ 232,640,704.00	\$ 64,352,205.00	\$ 3,167,528,473.00
10B/D	\$ 2,317,457,349.00	\$ 212,732,318.00	\$ 29,974,800.00	\$ 2,560,164,467.00
10C	\$ 4,015,591,421.00	\$ 367,398,736.00	\$ 49,979,087.00	\$ 4,432,969,244.00
11C	\$ 1,339,225,237.00	\$ 40,244,145.00	\$ 119,761,800.00	\$ 1,499,231,182.00
11D	\$ 930,848,401.00	\$ 28,324,098.00	\$ 83,183,700.00	\$ 1,042,356,199.00
12B	\$ 201,721,357.00	\$ 6,609,239.00	\$ 21,101,197.00	\$ 229,431,793.00
12C	\$ 511,972,714.00	\$ 16,210,040.00	\$ 48,847,700.00	\$ 577,030,454.00
12D	\$ 455,805,660.00	\$ 14,640,987.00	\$ 43,771,448.00	\$ 514,218,095.00
13A	\$ 259,080,175.00	\$ 18,833,859.00	\$ 31,139,598.00	\$ 309,053,632.00
13B	\$ 28,476,225.00	\$ 2,619,813.00	\$ 67,524,069.00	\$ 98,620,107.00
14	\$ 104,093,232.00	\$ 8,959,721.00	\$ 6,354,718.00	\$ 119,407,671.00



## Project Cost Estimating System SUMMARY PAGE

<b>DISTRICT</b>	<b>HAMPTON ROADS</b>		
<b>PROJECT NUMBER</b>	<b>64965081</b>		
<b>CONSTRUCTION END YEAR</b>	<b>FY2016</b>	<b>UPC</b>	<b>106724</b>
<b>AD YEAR</b>	<b>FY2016</b>	<b>RATE OF INFLATION TO AD</b>	<b>N/A</b>
<b>ESTIMATE YEAR</b>	<b>FY2016</b>	<b>INFLATION RATE DURING CN</b>	<b>N/A</b>
Date of previous estimate	01/28/16		
<b>PROJECT MANAGER / DESIGNER</b>	<b>Scott.Smizik</b>		
Preliminary Engineering Estimate:	<b>PCES</b>		
Construction Estimate:	<b>PCES</b>		
Right-of-Way Estimate:	<b>MANUAL</b>		
Utilities Estimate:	<b>MANUAL</b>		
<b>DATE</b>	<b>6/30/2016</b>		

THE FOLLOWING DATA WILL BE PROVIDED UPON COMPLETION OF THE REMAINDER OF THE WORKBOOK, WHICH IS ACCESSED BY SELECTING THE CONST, RW, & UTIL TABS BELOW

<b>CONSTRUCTION ESTIMATE</b>	<b>\$45,989,670</b>
<b>PRELIMINARY ENGINEERING ESTIMATE</b>	<b>\$4,027,384</b>
<b>RIGHT-OF-WAY &amp; UTILITIES ESTIMATE</b>	<b>\$3,492,315</b>
<b>TOTAL PROJECT ESTIMATE</b>	<b>\$53,509,369</b>

© Virginia Department of Transportation 2005

Revised 01/21/16

Estimate Class: Blank

Version 6.00

Project Cost Estimating System

CONSTRUCTION / BRIDGE / PE

Project No. **64965081**

Interstate Project ?

Route Number   **Interstate Highway**

	CONST-1	CONST-2	Bridges (0)	Total
Geometric Standard	GS-5			
Construction Base	\$33,029,244	\$0	\$7,799,000	\$40,828,244
Bridge Removal			\$0	\$0
CE	\$4,128,656		\$1,032,770	\$5,161,426
Construction Estimate (2016)	\$37,157,900		\$8,831,770	\$45,989,670
To AdYear Inflation				\$0
Mid-point construction Inflation				\$0
Total Construction Estimate			\$8,831,770	\$45,989,670
Preliminary Engineering Cost	\$3,418,527		\$608,858	\$4,027,384

### CONSTRUCTION & PE TOTALS

**Total Construction Estimate** **\$45,989,670** **PCES**  
 (Roadway plus Bridge)

**Total Preliminary Engineering Estimate** **\$4,027,384** **PCES**  
 (Roadway plus Bridge)

Project Cost Estimating System

CONSTRUCTION / BRIDGE / PE

Project No. **64965081**

Interstate Project ?	<input type="text" value="Yes"/>	*									
Maintenance Project ?	<input type="text" value="No"/>	*									
Route Number	<input type="text" value="664"/>	*	Interstate Highway								
Select INTERSTATE >	<input type="text" value="GS-5"/>	*	Principal Arterial - Freeway								
Ad Date	<input type="text" value="2016"/>		Design Year = 2038								
Design Year ADT	<input type="text" value="69,200"/>	*	Project Terrain <input type="text" value="Level"/>								
<i>Box Must Be Empty</i>	<input type="text"/>		Approx. DHV = 10,380								
Enter Design Speed (MPH) (Enter 60 or 70)	<input type="text" value="70"/>	*	Minimum Design Speed = 70 MPH								
<i>Box Must Be Empty</i>	<input type="text"/>										
<i>Box Must Be Empty</i>	<input type="text"/>										
Project Length (mi.)	<input type="text" value="1.36"/>	*	<table border="0" style="width: 100%; font-size: small;"> <tr> <td style="text-align: center;"><i>Number of Additional Lanes:</i></td> <td style="text-align: center;"><i>Length of Add'l. Lanes (mi.):</i></td> </tr> <tr> <td style="text-align: center;"><input type="text" value="+ One Add'l. Lane"/></td> <td style="text-align: center;"><input type="text" value="0.14"/></td> </tr> <tr> <td style="text-align: center;"><input type="text" value="None"/></td> <td style="text-align: center;"><input type="text"/></td> </tr> <tr> <td style="text-align: center;"><input type="text" value="None"/></td> <td style="text-align: center;"><input type="text"/></td> </tr> </table>	<i>Number of Additional Lanes:</i>	<i>Length of Add'l. Lanes (mi.):</i>	<input type="text" value="+ One Add'l. Lane"/>	<input type="text" value="0.14"/>	<input type="text" value="None"/>	<input type="text"/>	<input type="text" value="None"/>	<input type="text"/>
<i>Number of Additional Lanes:</i>	<i>Length of Add'l. Lanes (mi.):</i>										
<input type="text" value="+ One Add'l. Lane"/>	<input type="text" value="0.14"/>										
<input type="text" value="None"/>	<input type="text"/>										
<input type="text" value="None"/>	<input type="text"/>										
Total Length - Adding or Building <u>Two Lanes</u> (mi.)	<input type="text" value="0.83"/>	*									
Total Length - Adding or Building <u>Four Lanes</u> (mi.)	<input type="text"/>	*									
Total Length - Building <u>Ramps and Loops</u> (mi.)	<input type="text"/>	*									
Shoulder or Curb & Gutter ? (Select S or C&G)	<input type="text" value="S"/>	*	Enter Lane Width (ft) > <input type="text"/>								
Median Type - Graded, Raised, or None ?	<input type="text" value="G"/>	*	Normal Lane Width(ft) <input type="text" value="12"/>								
Number of Crossovers (Divided Highways ONLY)	<input type="text"/>	*									
Length - Curb & Gutter - Left PLUS Right Side (ft.)	<input type="text"/>										
Length - Sidewalk - Left PLUS Right Side (ft.)	<input type="text"/>										
Bike / Pedestrian Type	<input type="text" value="None"/>										
Total Length - Raised Median (ft.)	<input type="text"/>										
Number of <u>Right Turn Lanes</u> - Left PLUS Right Side	<input type="text"/>	*									
Number of Left Turn Lanes - (Undivided Only)	<input type="text"/>	*									

**HAMPTON ROADS**  
 110% Cost Factor used

Construction Costs

Signals, ITS, Signs and Lighting Costs*	<input type="text" value="\$1,447,129"/>		Base #1 (PCES)	<input type="text" value="\$33,029,244"/>
Cost of Large Drainage Structures	<input type="text" value="\$0"/>		Base #2	<input type="text" value="\$0"/>
In-Plan Utility Costs*	<input type="text" value="\$0"/>		Enter Const CE Cost >	<input type="text" value="\$0"/>
Adjustment for Unusual Construction Costs	<input type="text" value="\$26,228,722"/>		CE (12.5%)	<input type="text" value="\$4,128,656"/>
* Totals include district factor calculations			Estimate (2016)	<input type="text" value="\$37,157,900"/>

Additional (or Unusual) P. E. Costs	<input type="text"/>	
Select % of PE to be performed by Consultants	<input type="text" value="30%"/>	PE Cost (PCES) <input type="text" value="\$3,418,527"/>

**Note: Do Not Include Bridge P. E. Costs Here**

Roadway P. E. / Roadway Const. = 9.2%

© Virginia Department of Transportation 2005  
Revised 01/21/16

**Today's Date: 06/30/16**

**Version 6.00**

<b>Project Cost Estimating System</b> Miscellaneous Cost Estimates		
<b>COST OF LARGE DRAINAGE STRUCTURES</b>		
Job#	Description	Cost ()
<input type="text"/>	<input type="text"/>	<input type="text"/>
<input type="text"/>	<input type="text"/>	<input type="text"/>
<input type="text"/>	<input type="text"/>	<input type="text"/>
<input type="text"/>	<input type="text"/>	<input type="text"/>
<input type="text"/>	<input type="text"/>	<input type="text"/>
		<b>\$0</b>
<b>ADJUSTMENT FOR UNUSUAL CONSTRUCTION COSTS</b>		
Type	Description	Cost ()
Maintenance of Traffic	20% of roadway costs for MOT	\$3,480,838
Other	5% of roadway and structures costs for landscaping	\$1,260,160
Other	Resurfacing existing roadways	\$2,049,988
Other	Excessive excavation	\$0
Other	Excessive borrow	\$0
Other	Concrete barrier	\$377,191
Other	Guardrail and end treatments	\$1,209,741
Other	Removal of existing guardrail	\$20,768
Other	Demolition of existing pavement	\$115,186
Other	Noise barriers	\$0
Other	Retaining walls	\$2,533,312
Other	Tunnel costs	\$0
Other	Major in-plan utility work (water and sanitary sewer)	\$46,200
Other	Wet ponds and bioretention facilities	\$725,000
Environmental	Wetland and stream impacts	\$973,410
Environmental	Historic and archaeological resources	\$4,000,000
		<input type="text"/>
		<input type="text"/>
Other	40% contingency added to base construction cost	\$9,436,927
		<b>\$26,228,722</b>

Version 6.00



**SIGNALS, ITS, SIGNS and LIGHTING COST WORKSHEET**

Stand Alone Traffic Project:  No

UPC: 106724

**SIGNALS**

Permanent Signals	New/Mod.	Intersection Type	Major				Cross				Poles	Detection	Pre-emption	Cost
			Direction	Lanes	Direction	Lanes	Direction	Lanes	Direction	Lanes				
Location/Description														
1														\$0
2														\$0
3														\$0
4														\$0
5														\$0
6														\$0
7														\$0
8														\$0
9														\$0
10														\$0

	Quantity	Cost
Temporary Signals - New Equipment		\$0
Temporary Signals - Modified Equipment		\$0

MISCELLANEOUS SIGNAL WORK	Location/Description	Cost
1		
2		
<b>Signals Construction Subtotal</b>		<b>\$0</b>

ITS	Location/Description	Cost
ITS WORK		
1		
2		
<b>ITS Construction Subtotal</b>		<b>\$0</b>

MAJOR SIGN STRUCTURES		Type of Sign	Comment	Quantity	Unit	Lighted Y/N	Cost/Sign	Extended Cost
1	O/H Span (50-100)			5	Ea.	No	112,819	\$564,093
2					Ea.			
3					Ea.			
4					Ea.			
5					Ea.			
6					Ea.			
7					Ea.			
MISCELLANEOUS SIGN WORK								Cost
1	Add mile post markers at \$1,000/mile for 1.36 miles							\$1,360
2								
<b>Signs Construction Subtotal</b>								<b>\$565,453</b>

LIGHTING							Number of Miles	Cost
Continuous Roadway								
1	Urban Type of Lighting	Comments	No. Lanes				\$0	
1	Freeway Type of Lighting	Comments	No. Lanes	6	1.36		\$750,119	
Interchange							Number of Interchanges	Cost
1	Interchange Type	Type of Lighting					\$0	
2							\$0	
3							\$0	
Miscellaneous							Cost	
1	Location/Description							
2								
<b>Lighting Construction Subtotal</b>							<b>\$750,119</b>	
<b>CONSTRUCTION TOTAL</b>							<b>\$1,315,572</b>	

*District factor will be applied when the total cost is passed to the const-1 worksheet*

PROJECT COMMENTS

Prepared by: CMS

Date Prepared/Modified: 05/05/16

Version 6.00

# BRIDGE CONSTRUCTION AND PRELIMINARY ENGINEERING COSTS

BRIDGE  
CONSTRUCTION

BRIDGE  
P. E.

Bridge Job #

Federal Structure ID

Manual CEI Cost Override :

Bridge # 1 CEI Cost :

17%

Manual PE Cost Adjustment :

Bridge #1 CN + CEI Cost :

P.E. Bridge # 1

BRIDGE #1 CN Cost : (input from Bridge PCES worksheet)

Comments - Constr. Engr. Br. #1:

Comments - Misc. P.E. Bridge #1:

Bridge Job #

Federal Structure ID

Manual CEI Cost Override :

Bridge # 2 CEI Cost :

14.0%

Manual PE Cost Adjustment :

Bridge #2 CN + CEI Cost :

P.E. Bridge # 2

BRIDGE #2 CN Cost : (input from Bridge PCES worksheet)

Comments - Constr. Engr. Br. #2:

Comments - Misc. P.E. Bridge #2:

Bridge Job #

Federal Structure ID

Manual CEI Cost Override :

Bridge # 3 CEI Cost :   
12.0%

Manual PE Cost Adjustment :

BRIDGE #3 CN Cost : (input from Bridge PCES worksheet)

Bridge #3 CN + CEI Cost :



P.E. Bridge # 3

Comments - Constr. Engr. Br. #3:

Comments - Misc. P.E. Bridge #3:

BRIDGE CONSTRUCTION AND PE COSTS (continued)			
		<i>Bridge Construction Base (PCES)</i>	\$7,799,000
<i>Bike / PED Construction Cost</i>	\$0		
<i>Bike / PED CE</i>	\$0	<i>Bridge Removal</i>	\$0
<i>Bike / PED PE</i>	\$0	<i>Bridge CE (PCES)</i>	\$1,032,770
<b>NOTE : Structure Complexity is based upon Height,</b>		<b>Bridge Estimate. (2016)</b>	<b>\$8,831,770</b>
<b>Difficulty of Construction, and other Factors</b>		<b>Total Bridge P. E. Costs (PCES)</b>	<b>\$608,858</b>

Version 6.00

 <b>Project Cost Estimating System</b> <b>COMMENTS</b> 		
<b>General / Miscellaneous Comments from CONST, RW, &amp; UTILITY Worksheets</b>	<b>Team Member and Section</b>	<b>Date Entered</b>
<b>1</b> Project terrain changed from rolling to level based on comments from L&D on draft cost estimate	C. Sutkowski - HRCS Team	06/23/16
<b>2</b> Moved 10% of roadway and structures costs for general utility relocation from CONST-MISC sheet to MANUAL sheet	C. Sutkowski - HRCS Team	06/27/16
<b>3</b> Input revised bridge costs based on comments from S&B on draft cost estimate	C. Sutkowski - HRCS Team	06/28/16
<b>4</b> Included costs for noise barriers in segment estimate as provided by noise team	C. Sutkowski - HRCS Team	06/28/16
<b>5</b> Updated costs for right-of-way with contingency added in line item in MANUAL sheet	C. Sutkowski - HRCS Team	06/29/16
<b>6</b> Added costs for right-of-way for stormwater management in MANUAL sheet	C. Sutkowski - HRCS Team	06/29/16
<b>7</b>		
<b>8</b>		
<b>9</b>		
<b>10</b>		
<b>11</b>		
<b>12</b>		
<b>13</b>		
<b>14</b>		
<b>15</b>		

**VDOT Project Cost Estimating System  
MANUAL ESTIMATE**

	DATE	PE	RW	CN
<b>EXPENDITURES</b>	01/20/16	\$839,552		\$0
<b>RUMS</b>	01/28/16			\$0
<b>TRNS*PORT</b>				\$0
<b>AWARD</b>	01/28/16			\$0
<b>PROJECTION</b>	01/28/16			\$0

**ESTIMATE YEAR**

**AD YEAR**

FY2016		FY2016
\$0	PE	\$0
\$3,492,315	RW	\$3,492,315
\$0	CN	\$0
\$3,492,315	<b>TOTAL</b>	\$3,492,315

Job #	Phase	Comment	Estimate
	RW	10% of roadway and structures costs for general utility relocation	\$2,520,319
	RW	Cost for utility work under RW project. See file Utilities Cost Estimate All Segments(AWP).xls	\$78,751
	RW	Cost for Right-of-Way. See file HRCS ROW Costs.xlsx	\$623,958
	RW	Cost for Right-of-Way for Stormwater Management. See file HRCS ROW Costs.xlsx	\$269,287

Job #	Phase	Comment	Estimate
-------	-------	---------	----------





## Project Cost Estimating System SUMMARY PAGE

<b>DISTRICT</b>	<b>HAMPTON ROADS</b>		
<b>PROJECT NUMBER</b>	<b>64965081</b>		
<b>CONSTRUCTION END YEAR</b>	<b>FY2016</b>	<b>UPC</b>	<b>106724</b>
<b>AD YEAR</b>	<b>FY2016</b>	<small>RATE OF INFLATION TO AD</small>	<b>N/A</b>
<b>ESTIMATE YEAR</b>	<b>FY2016</b>	<small>INFLATION RATE DURING CN</small>	<b>N/A</b>
<small>Date of previous estimate</small>	01/28/16		
<b>PROJECT MANAGER / DESIGNER</b>	<b>Scott.Smizik</b>		
<b>Preliminary Engineering Estimate:</b>	<b>PCES</b>		
<b>Construction Estimate:</b>	<b>PCES</b>		
<b>Right-of-Way Estimate:</b>	<b>MANUAL</b>		
<b>Utilities Estimate:</b>	<b>MANUAL</b>		
<b>DATE</b>	<b>6/30/2016</b>		

THE FOLLOWING DATA WILL BE PROVIDED UPON COMPLETION OF THE REMAINDER OF THE WORKBOOK, WHICH IS ACCESSED BY SELECTING THE CONST, RW, & UTIL TABS BELOW

<b>CONSTRUCTION ESTIMATE</b>	<b>\$168,229,912</b>
<b>PRELIMINARY ENGINEERING ESTIMATE</b>	<b>\$14,130,200</b>
<b>RIGHT-OF-WAY &amp; UTILITIES ESTIMATE</b>	<b>\$12,671,335</b>
<b>TOTAL PROJECT ESTIMATE</b>	<b>\$195,031,447</b>

	Project Cost Estimating System CONSTRUCTION / BRIDGE / PE	
---	--	---

Project No. **64965081**

Interstate Project ?

Route Number   **Interstate Highway**

	CONST-1	CONST-2	Bridges (0)	Total
Geometric Standard	GS-5			
Construction Base	\$117,351,593	\$0	\$32,266,000	\$149,617,593
Bridge Removal			\$0	\$0
CE	\$14,668,949		\$3,943,370	\$18,612,319
Construction Estimate (2016)	\$132,020,542		\$36,209,370	\$168,229,912
To AdYear Inflation				\$0
Mid-point construction Inflation				\$0
Total Construction Estimate			\$36,209,370	<b>\$168,229,912</b>
Preliminary Engineering Cost	\$12,145,890		\$1,984,310	\$14,130,200

### CONSTRUCTION & PE TOTALS

Total Construction Estimate **\$168,229,912** **PCES**  
 (Roadway plus Bridge)

Total Preliminary Engineering Estimate **\$14,130,200** **PCES**  
 (Roadway plus Bridge)



Project Cost Estimating System

CONSTRUCTION / BRIDGE / PE

Project No. **64965081**

Interstate Project ?	<input type="text" value="Yes"/>	*					
Maintenance Project ?	<input type="text" value="No"/>	*					
Route Number	<input type="text" value="664"/>	*	Interstate Highway				
Select INTERSTATE >	<input type="text" value="GS-5"/>	*	Principal Arterial - Freeway				
Ad Date	<input type="text" value="2016"/>		Design Year = 2038				
Design Year ADT	<input type="text" value="69,700"/>	*	Project Terrain <input type="text" value="Level"/>				
<i>Box Must Be Empty</i>	<input type="text"/>		Approx. DHV = 10,455				
Enter Design Speed (MPH) (Enter 60 or 70)	<input type="text" value="70"/>	*	Minimum Design Speed = 70 MPH				
<i>Box Must Be Empty</i>	<input type="text"/>						
<i>Box Must Be Empty</i>	<input type="text"/>						
Project Length (mi.)	<input type="text" value="4.73"/>	*					
Total Length - Adding or Building <u>Two Lanes</u> (mi.)	<input type="text" value="4.50"/>	*	<table border="0" style="width: 100%;"> <tr> <td style="text-align: center;"><i>Number of Additional Lanes:</i></td> <td style="text-align: center;"><i>Length of Add'l. Lanes (mi.):</i></td> </tr> <tr> <td style="text-align: center;"><input type="text" value="None"/></td> <td style="text-align: center;"><input type="text"/></td> </tr> </table>	<i>Number of Additional Lanes:</i>	<i>Length of Add'l. Lanes (mi.):</i>	<input type="text" value="None"/>	<input type="text"/>
<i>Number of Additional Lanes:</i>	<i>Length of Add'l. Lanes (mi.):</i>						
<input type="text" value="None"/>	<input type="text"/>						
Total Length - Adding or Building <u>Four Lanes</u> (mi.)	<input type="text"/>	*	<input type="text" value="None"/>				
Total Length - Building <u>Ramps and Loops</u> (mi.)	<input type="text"/>	*	<input type="text" value="None"/>				
Shoulder or Curb & Gutter ? (Select S or C&G)	<input type="text" value="S"/>	*	Enter Lane Width (ft) > <input type="text"/>				
Median Type - Graded, Raised, or None ?	<input type="text" value="G"/>	*	Normal Lane Width(ft) <input type="text" value="12"/>				
Number of Crossovers (Divided Highways ONLY)	<input type="text"/>	*					
Length - Curb & Gutter - Left PLUS Right Side (ft.)	<input type="text"/>						
Length - Sidewalk - Left PLUS Right Side (ft.)	<input type="text"/>						
Bike / Pedestrian Type	<input type="text" value="None"/>						
Total Length - Raised Median (ft.)	<input type="text"/>						
Number of <u>Right Turn Lanes</u> - Left PLUS Right Side	<input type="text"/>	*					
Number of Left Turn Lanes - (Undivided Only)	<input type="text"/>	*					

**HAMPTON ROADS**  
 110% Cost Factor used  
**Construction Costs**

Signals, ITS, Signs and Lighting Costs*	<input type="text" value="\$4,644,894"/>		Base #1 (PCES)	<input type="text" value="\$117,351,593"/>
Cost of Large Drainage Structures	<input type="text" value="\$109,200"/>		Base #2	<input type="text" value="\$0"/>
In-Plan Utility Costs*	<input type="text" value="\$0"/>		Enter Const CE Cost >	<input type="text" value="\$0"/>
Adjustment for Unusual Construction Costs	<input type="text" value="\$89,387,559"/>		CE (12.5%)	<input type="text" value="\$14,668,949"/>
<i>* Totals include district factor calculations</i>			Estimate (2016)	<input type="text" value="\$132,020,542"/>

Additional (or Unusual) P. E. Costs	<input type="text"/>	
Select % of PE to be performed by Consultants	<input type="text" value="30%"/>	PE Cost (PCES) <input type="text" value="\$12,145,890"/>



**Note: Do Not Include Bridge P. E. Costs Here**

Roadway P. E. / Roadway Const. = 9.2%

© Virginia Department of Transportation 2005  
Revised 01/21/16

**Today's Date: 06/30/16**

**Version 6.00**

	<b>Project Cost Estimating System</b> <b>Miscellaneous Cost Estimates</b>	
---	--	---

**COST OF LARGE DRAINAGE STRUCTURES**

Job#	Description	Cost ()
XXXXXX	Culvert Extension Under I-664 and CSX Railroad; 0.1 mi north of Pugh	\$109,200
		<b>\$109,200</b>

**ADJUSTMENT FOR UNUSUAL CONSTRUCTION COSTS**

Type	Description	Cost ()
Maintenance of Traffic	20% of roadway costs for MOT	\$12,410,300
Other	5% of roadway and structures costs for landscaping	\$4,715,875
Other	Resurfacing existing roadways	\$5,558,937
Other	Excessive excavation	\$0
Other	Excessive borrow	\$0
Other	Concrete barrier	\$1,254,568
Other	Guardrail and end treatments	\$5,436,401
Other	Removal of existing guardrail	\$88,604
Other	Demolition of existing pavement	\$550,448
Other	Noise barriers	\$12,950,746
Other	Retaining walls	\$3,321,193
Other	Tunnel costs	\$0
Other	Major in-plan utility work (water and sanitary sewer)	\$120,900
Other	Wet ponds and bioretention facilities	\$3,175,000
Environmental	Wetland and stream impacts	\$275,560
Environmental	Historic and archaeological resources	\$6,000,000
Other	40% contingency added to base construction cost	\$33,529,027
		<b>\$89,387,559</b>

Version 6.00

**SIGNALS, ITS, SIGNS and LIGHTING COST WORKSHEET**

Stand Alone Traffic Project:  No

UPC: 106724

SIGNALS		New/Mod.	Intersection Type	Major				Cross				Poles	Detection	Pre-emption	Cost
Permanent Signals				Direction	Lanes	Direction	Lanes	Direction	Lanes	Direction	Lanes				
Location/Description															
1															\$0
2															\$0
3															\$0
4															\$0
5															\$0
6															\$0
7															\$0
8															\$0
9															\$0
10															\$0

Temporary Signals - New Equipment	Quantity	Cost
Temporary Signals - Modified Equipment		\$0

MISCELLANEOUS SIGNAL WORK	Location/Description	Cost
1		
2		

Signals Construction Subtotal \$0

ITS	Location/Description	Cost
ITS WORK 1		
2		

ITS Construction Subtotal \$0

MAJOR SIGN STRUCTURES		Quantity	Unit	Lighted Y/N	Included in Roadway Lighting? yes/no	Cost/Sign	Extended Cost
1	O/H Span (50-100)	13	Ea.	No		112,819	\$1,466,642
2	Cantilever	2	Ea.	Yes		57,909	\$115,819
3	Bridge Mount	1	Ea.	Yes		26,571	\$26,571
4			Ea.				
5			Ea.				
6			Ea.				
7			Ea.				

MISCELLANEOUS SIGN WORK	Location/Description	Cost
1	Add mile post markers at \$1,000/mile for 4.73 mile	\$4,730
2		

Signs Construction Subtotal \$1,613,762

LIGHTING		Comments		No. Lanes	Number of Miles	Cost
<b>Continuous Roadway</b>						
1	Urban Type of Lighting					\$0
1	Freeway Type of Lighting			6	4.73	\$2,608,869
<b>Interchange</b>						
1	Interchange Type	Type of Lighting			Number of Interchanges	Cost
2						\$0
3						\$0
<b>Miscellaneous</b>						
1	Location/Description					Cost
2						

Lighting Construction Subtotal \$2,608,869

**CONSTRUCTION TOTAL \$4,222,630**

*District factor will be applied when the total cost is passed to the const-1 worksheet*

PROJECT COMMENTS

Prepared by: CMS

Date Prepared/Modified: 05/05/16

Version 6.00

## BRIDGE CONSTRUCTION AND PRELIMINARY ENGINEERING COSTS

BRIDGE  
CONSTRUCTION

BRIDGE  
P. E.

Bridge Job #

Federal Structure ID

Manual CEI Cost Override :

Bridge # 1 CEI Cost : \$232,960  
16%

Manual PE Cost Adjustment :

Bridge #1 CN + CEI Cost :

P.E. Bridge # 1

BRIDGE #1 CN Cost : (input from Bridge PCES worksheet) \$1,456,000

Comments - Constr. Engr. Br. #1:

Comments - Misc. P.E. Bridge #1:

Bridge Job #

Federal Structure ID

Manual CEI Cost Override :

Bridge # 2 CEI Cost : \$284,620  
14.0%

Manual PE Cost Adjustment :

Bridge #2 CN + CEI Cost :

P.E. Bridge # 2

BRIDGE #2 CN Cost : (input from Bridge PCES worksheet) \$2,033,000

Comments - Constr. Engr. Br. #2:

Comments - Misc. P.E. Bridge #2:

Bridge Job #

Federal Structure ID

Manual CEI Cost Override :

Bridge # 3 CEI Cost :   
13.0%

Manual PE Cost Adjustment :

BRIDGE #3 CN Cost : (input from Bridge PCES worksheet)

Bridge #3 CN + CEI Cost :

P.E. Bridge # 3

Comments - Constr. Engr. Br. #3:

Comments - Misc. P.E. Bridge #3:

BRIDGE CONSTRUCTION AND PE COSTS (continued)

BRIDGE CONSTRUCTION

BRIDGE P. E.

Bridge Job #

[Yellow box]

Federal Structure ID

23106

Manual CEI Cost Override :

[Yellow box]  
\$423,020

Bridge # 4 CEI Cost :

13.0%

Manual PE Cost Adjustment :

[Yellow box]

Bridge #4 CN + CEI Cost :

\$3,677,020

P.E. Bridge # 4

BRIDGE #4 CN Cost : (input from Bridge PCES worksheet) \$3,254,000

\$223,531

Comments - Constr. Engr. Br. #4:

[White box]

Comments - Misc. P.E. Bridge #4:

[White box]

Bridge Job #

[Yellow box]

Federal Structure ID

23102

Manual CEI Cost Override :

[Yellow box]  
\$423,020

Bridge # 5 CEI Cost :

13.0%

Manual PE Cost Adjustment :

[Yellow box]

Bridge #5 CN + CEI Cost :

\$3,677,020

P.E. Bridge # 5

BRIDGE #5 CN Cost : (input from Bridge PCES worksheet) \$3,254,000

\$223,531

Comments - Constr. Engr. Br. #5:

[White box]

Comments - Misc. P.E. Bridge #5:

[White box]

Bridge Job #

[Yellow box]

Federal Structure ID

23103

Manual CEI Cost Override :

Bridge # 6 CEI Cost :

\$423,020

13.0%

Manual PE Cost Adjustment :

BRIDGE #6 CN Cost : (input from Bridge PCES worksheet)

Bridge #6 CN + CEI Cost :

P.E. Bridge # 6

Comments - Constr. Engr. Br. #6:

Comments - Misc. P.E. Bridge #6:



BRIDGE CONSTRUCTION AND PE COSTS (continued)

BRIDGE CONSTRUCTION

BRIDGE P. E.

Bridge Job #

[Yellow box]

Federal Structure ID

23112

Manual CEI Cost Override :

[Yellow box]

Bridge # 7 CEI Cost : \$985,270

11.0%

Manual PE Cost Adjustment :

[Yellow box]

Bridge #7 CN + CEI Cost :

\$9,942,270

P.E. Bridge # 7

\$402,891

BRIDGE #7 CN Cost : (input from Bridge PCES worksheet) \$8,957,000

Comments - Constr. Engr. Br. #7:

[White box]

Comments - Misc. P.E. Bridge #7:

[White box]

Bridge Job #

[Yellow box]

Federal Structure ID

23104

Manual CEI Cost Override :

[Yellow box]

Bridge # 8 CEI Cost : \$748,440

11.0%

Manual PE Cost Adjustment :

[Yellow box]

Bridge #8 CN + CEI Cost :

\$7,552,440

P.E. Bridge # 8

\$335,179

BRIDGE #8 CN Cost : (input from Bridge PCES worksheet) \$6,804,000

Comments - Constr. Engr. Br. #8:

[White box]

Comments - Misc. P.E. Bridge #8:

[White box]

Bridge Job #

[Yellow box]

Federal Structure ID

[Yellow box]

Manual CEI Cost Override :

Bridge # 9 CEI Cost :

18.0%

Manual PE Cost Adjustment :

BRIDGE #9 CN Cost : (input from Bridge PCES worksheet)



Bridge #9 CN + CEI Cost :

P.E. Bridge # 9

Comments - Constr. Engr. Br. #9:

Comments - Misc. P.E. Bridge #9:

BRIDGE CONSTRUCTION AND PE COSTS (continued)			
		<i>Bridge Construction Base (PCES)</i>	\$32,266,000
<i>Bike / PED Construction Cost</i>	\$0		
<i>Bike / PED CE</i>	\$0	<i>Bridge Removal</i>	\$0
<i>Bike / PED PE</i>	\$0	<i>Bridge CE (PCES)</i>	\$3,943,370
<b>NOTE : Structure Complexity is based upon Height,</b>		<b>Bridge Estimate. (2016)</b>	<b>\$36,209,370</b>
<b>Difficulty of Construction, and other Factors</b>		<b>Total Bridge P. E. Costs (PCES)</b>	<b>\$1,984,310</b>
			<b>Version 6.00</b>

 Project Cost Estimating System <b>COMMENTS</b> 		
<b>General / Miscellaneous Comments from CONST, RW, &amp; UTILITY Worksheets</b>	<b>Team Member and Section</b>	<b>Date Entered</b>
<b>1</b> Project terrain changed from rolling to level based on comments from L&D on draft cost estimate	C. Sutkowski - HRCS Team	06/23/16
<b>2</b> Moved 10% of roadway and structures costs for general utility relocation from CONST-MISC sheet to MANUAL sheet	C. Sutkowski - HRCS Team	06/27/16
<b>3</b> Input revised bridge costs based on comments from S&B on draft cost estimate	C. Sutkowski - HRCS Team	06/28/16
<b>4</b> Included costs for noise barriers in segment estimate as provided by noise team	C. Sutkowski - HRCS Team	06/29/16
<b>5</b> Updated costs for right-of-way with contingency added in line item in MANUAL sheet	C. Sutkowski - HRCS Team	06/29/16
<b>6</b> Added costs for right-of-way for stormwater management in MANUAL sheet	C. Sutkowski - HRCS Team	06/29/16
<b>7</b>		
<b>8</b>		
<b>9</b>		
<b>10</b>		
<b>11</b>		
<b>12</b>		
<b>13</b>		
<b>14</b>		
<b>15</b>		

UPC: 106724

**VDOT Project Cost Estimating System  
MANUAL ESTIMATE**

	DATE	PE	RW	CN
<b>EXPENDITURES</b>	01/20/16	\$839,552		\$0
<b>RUMS</b>	01/28/16			\$0
<b>TRNS*PORT</b>				\$0
<b>AWARD</b>	01/28/16			\$0
<b>PROJECTION</b>	01/28/16			\$0

**ESTIMATE YEAR**

**AD YEAR**

FY2016		FY2016
\$0	PE	\$0
\$12,671,335	RW	\$12,671,335
\$0	CN	\$0
\$12,671,335	<b>TOTAL</b>	\$12,671,335

Job #	Phase	Comment	Estimate
	RW	10% of roadway and structures costs for general utility relocation	\$9,431,750
	RW	Cost for utility work under RW project. See file Utilities Cost Estimate All Segments(AWP).xls	\$297,650
	RW	Cost for Right-of-Way. See file HRCS ROW Costs.xlsx	\$1,529,820
	RW	Cost for Right-of-Way for Stormwater Management. See file HRCS ROW Costs.xlsx	\$1,412,115

Job #	Phase	Comment	Estimate
-------	-------	---------	----------



## Project Cost Estimating System SUMMARY PAGE

<b>DISTRICT</b>	<b>HAMPTON ROADS</b>		
<b>PROJECT NUMBER</b>	<b>64965081</b>		
<b>CONSTRUCTION END YEAR</b>	<b>FY2016</b>	<b>UPC</b>	<b>106724</b>
<b>AD YEAR</b>	<b>FY2016</b>	<small>RATE OF INFLATION TO AD</small>	<b>N/A</b>
<b>ESTIMATE YEAR</b>	<b>FY2016</b>	<small>INFLATION RATE DURING CN</small>	<b>N/A</b>
<small>Date of previous estimate</small>	<small>01/28/16</small>		
<b>PROJECT MANAGER / DESIGNER</b>	<b>Scott.Smizik</b>		
<b>Preliminary Engineering Estimate:</b>	<b>PCES</b>		
<b>Construction Estimate:</b>	<b>PCES</b>		
<b>Right-of-Way Estimate:</b>	<b>MANUAL</b>		
<b>Utilities Estimate:</b>	<b>MANUAL</b>		
<b>DATE</b>	<b>6/30/2016</b>		

THE FOLLOWING DATA WILL BE PROVIDED UPON COMPLETION OF THE REMAINDER OF THE WORKBOOK, WHICH IS ACCESSED BY SELECTING THE CONST, RW, & UTIL TABS BELOW

<b>CONSTRUCTION ESTIMATE</b>	<b>\$107,443,742</b>
<b>PRELIMINARY ENGINEERING ESTIMATE</b>	<b>\$8,323,689</b>
<b>RIGHT-OF-WAY &amp; UTILITIES ESTIMATE</b>	<b>\$7,407,544</b>
<b>TOTAL PROJECT ESTIMATE</b>	<b>\$123,174,975</b>

© Virginia Department of Transportation 2005

Revised 01/21/16

Estimate Class: Blank

Version 6.00

Project Cost Estimating System

CONSTRUCTION / BRIDGE / PE

Project No. **64965081**

Interstate Project ?

Route Number   **Interstate Highway**

	CONST-1	CONST-2	Bridges (0)	Total
Geometric Standard	GS-5			
Construction Base	\$54,566,441	\$0	\$40,918,000	\$95,484,441
Bridge Removal			\$0	\$0
CE	\$6,820,805		\$5,138,495	\$11,959,300
Construction Estimate (2016)	\$61,387,247		\$46,056,495	\$107,443,742
To AdYear Inflation				\$0
Mid-point construction Inflation				\$0
Total Construction Estimate			\$46,056,495	<b>\$107,443,742</b>
Preliminary Engineering Cost	\$5,647,627		\$2,676,062	\$8,323,689

### CONSTRUCTION & PE TOTALS

**Total Construction Estimate** **\$107,443,742** **PCES**  
 (Roadway plus Bridge)

**Total Preliminary Engineering Estimate** **\$8,323,689** **PCES**  
 (Roadway plus Bridge)

Project Cost Estimating System

CONSTRUCTION / BRIDGE / PE

Project No. **64965081**

Interstate Project ?	<input type="text" value="Yes"/>	*									
Maintenance Project ?	<input type="text" value="No"/>	*									
Route Number	<input type="text" value="664"/>	*	Interstate Highway								
Select INTERSTATE >	<input type="text" value="GS-5"/>	*	Principal Arterial - Freeway								
Ad Date	<input type="text" value="2016"/>		Design Year = 2038								
Design Year ADT	<input type="text" value="71,200"/>	*	Project Terrain <input type="text" value="Level"/>								
<i>Box Must Be Empty</i>	<input type="text"/>		Approx. DHV = 10,680								
Enter Design Speed (MPH) (Enter 60 or 70)	<input type="text" value="70"/>	*	Minimum Design Speed = 70 MPH								
<i>Box Must Be Empty</i>	<input type="text"/>										
<i>Box Must Be Empty</i>	<input type="text"/>										
Project Length (mi.)	<input type="text" value="0.77"/>	*	<table border="0" style="width: 100%; font-size: small;"> <tr> <td style="text-align: center;"><i>Number of Additional Lanes:</i></td> <td style="text-align: center;"><i>Length of Add'l. Lanes (mi.):</i></td> </tr> <tr> <td style="text-align: center;"><input type="text" value="+ One Add'l. Lane"/></td> <td style="text-align: center;"><input type="text" value="0.27"/></td> </tr> <tr> <td style="text-align: center;"><input type="text" value="None"/></td> <td style="text-align: center;"><input type="text"/></td> </tr> <tr> <td style="text-align: center;"><input type="text" value="None"/></td> <td style="text-align: center;"><input type="text"/></td> </tr> </table>	<i>Number of Additional Lanes:</i>	<i>Length of Add'l. Lanes (mi.):</i>	<input type="text" value="+ One Add'l. Lane"/>	<input type="text" value="0.27"/>	<input type="text" value="None"/>	<input type="text"/>	<input type="text" value="None"/>	<input type="text"/>
<i>Number of Additional Lanes:</i>	<i>Length of Add'l. Lanes (mi.):</i>										
<input type="text" value="+ One Add'l. Lane"/>	<input type="text" value="0.27"/>										
<input type="text" value="None"/>	<input type="text"/>										
<input type="text" value="None"/>	<input type="text"/>										
Total Length - Adding or Building <u>Two Lanes</u> (mi.)	<input type="text" value="0.51"/>	*									
Total Length - Adding or Building <u>Four Lanes</u> (mi.)	<input type="text"/>	*									
Total Length - Building <u>Ramps and Loops</u> (mi.)	<input type="text" value="1.24"/>	*									
Shoulder or Curb & Gutter ? (Select S or C&G)	<input type="text" value="S"/>	*	Enter Lane Width (ft) > <input type="text"/>								
Median Type - Graded, Raised, or None ?	<input type="text" value="G"/>	*	Normal Lane Width(ft) <input type="text" value="12"/>								
Number of Crossovers (Divided Highways ONLY)	<input type="text"/>	*									
Length - Curb & Gutter - Left PLUS Right Side (ft.)	<input type="text"/>										
Length - Sidewalk - Left PLUS Right Side (ft.)	<input type="text"/>										
Bike / Pedestrian Type	<input type="text" value="None"/>										
Total Length - Raised Median (ft.)	<input type="text"/>										
Number of <u>Right Turn Lanes</u> - Left PLUS Right Side	<input type="text"/>	*									
Number of Left Turn Lanes - (Undivided Only)	<input type="text"/>	*									

**HAMPTON ROADS**  
 110% Cost Factor used

Construction Costs

Signals, ITS, Signs and Lighting Costs*	<input type="text" value="\$1,661,236"/>	
Cost of Large Drainage Structures	<input type="text" value="\$0"/>	Base #1 (PCES) <input type="text" value="\$54,566,441"/>
In-Plan Utility Costs*	<input type="text" value="\$0"/>	Base #2 <input type="text" value="\$0"/>
Adjustment for Unusual Construction Costs	<input type="text" value="\$38,345,542"/>	Enter Const CE Cost > <input type="text" value="\$0"/>
		CE (12.5%) <input type="text" value="\$6,820,805"/>
		Estimate (2016) <input type="text" value="\$61,387,247"/>

\* Totals include district factor calculations

Additional (or Unusual) P. E. Costs	<input type="text"/>	
Select % of PE to be performed by Consultants	<input type="text" value="30%"/>	PE Cost (PCES) <input type="text" value="\$5,647,627"/>





**Note: Do Not Include Bridge P. E. Costs Here**

Roadway P. E. / Roadway Const. = 9.2%

© Virginia Department of Transportation 2005  
Revised 01/21/16

**Today's Date: 06/30/16**

**Version 6.00**

**Project Cost Estimating System**  
**Miscellaneous Cost Estimates**

**COST OF LARGE DRAINAGE STRUCTURES**

Job#	Description	Cost ()
<input type="text"/>	<input type="text"/>	<input type="text"/>
<input type="text"/>	<input type="text"/>	<input type="text"/>
<input type="text"/>	<input type="text"/>	<input type="text"/>
<input type="text"/>	<input type="text"/>	<input type="text"/>
<input type="text"/>	<input type="text"/>	<input type="text"/>
		<b>\$0</b>

**ADJUSTMENT FOR UNUSUAL CONSTRUCTION COSTS**

Type	Description	Cost ()
Maintenance of Traffic	20% of roadway costs for MOT	\$5,643,023
Other	5% of roadway and structures costs for landscaping	\$3,456,656
Other	Resurfacing existing roadways	\$1,398,374
Other	Excessive excavation	\$0
Other	Excessive borrow	\$0
Other	Concrete barrier	\$901,992
Other	Guardrail and end treatments	\$1,753,552
Other	Removal of existing guardrail	\$42,833
Other	Demolition of existing pavement	\$262,957
Other	Noise barriers	\$7,653,094
Other	Retaining walls	\$0
Other	Tunnel costs	\$0
Other	Major in-plan utility work	\$0
Other	Wet ponds and bioretention facilities	\$475,000
Environmental	Wetland and stream impacts	\$167,650
Environmental	Historic and archaeological resources	\$1,000,000
		<input type="text"/>
		<input type="text"/>
Other	40% contingency added to base construction cost	\$15,590,412
		<b>\$38,345,542</b>

Version 6.00

**SIGNALS, ITS, SIGNS and LIGHTING COST WORKSHEET**

Stand Alone Traffic Project:  No

UPC: 106724

**SIGNALS**

Permanent Signals	New/Mod.	Intersection Type	Major				Cross				Poles	Detection	Pre-emption	Cost
			Direction	Lanes	Direction	Lanes	Direction	Lanes	Direction	Lanes				
Location/Description														
1														\$0
2														\$0
3														\$0
4														\$0
5														\$0
6														\$0
7														\$0
8														\$0
9														\$0
10														\$0

	Quantity	Cost
Temporary Signals - New Equipment		\$0
Temporary Signals - Modified Equipment		\$0

MISCELLANEOUS SIGNAL WORK	Location/Description	Cost
1		
2		
<b>Signals Construction Subtotal</b>		<b>\$0</b>

ITS	Location/Description	Cost
ITS WORK		
1		
2		
<b>ITS Construction Subtotal</b>		<b>\$0</b>

MAJOR SIGN STRUCTURES		Type of Sign	Comment	Quantity	Unit	Lighted Y/N	Cost/Sign	Extended Cost
1	O/H Span (50-100)			2	Ea.	No	112,819	\$225,637
2					Ea.			
3					Ea.			
4					Ea.			
5					Ea.			
6					Ea.			
7					Ea.			
MISCELLANEOUS SIGN WORK								Cost
1	Add mile post markers at \$1,000/mile for 0.77 miles							\$770
2								
<b>Signs Construction Subtotal</b>								<b>\$226,407</b>

LIGHTING					Number of Miles	Cost
<b>Continuous Roadway</b>						
Urban Type of Lighting		Comments	No. Lanes			\$0
1						
Freeway Type of Lighting		Comments	No. Lanes			
1	Conventional		6	0.77		\$424,700
<b>Interchange</b>						
Interchange Type		Type of Lighting		Number of Interchanges		Cost
1	Cloverleaf	combination		1		\$859,108
2						\$0
3						\$0
<b>Miscellaneous</b>						
Location/Description						Cost
1						
2						
<b>Lighting Construction Subtotal</b>						<b>\$1,283,807</b>
<b>CONSTRUCTION TOTAL</b>						<b>\$1,510,215</b>

*District factor will be applied when the total cost is passed to the const-1 worksheet*

**PROJECT COMMENTS**

Prepared by: CMS

Date Prepared/Modified: 05/05/16

Version 6.00

# BRIDGE CONSTRUCTION AND PRELIMINARY ENGINEERING COSTS

BRIDGE  
CONSTRUCTION

BRIDGE  
P. E.

Bridge Job #

Federal Structure ID

Manual CEI Cost Override :

Bridge # 1 CEI Cost :

15%

Manual PE Cost Adjustment :

Bridge #1 CN + CEI Cost :

P.E. Bridge # 1

BRIDGE #1 CN Cost : (input from Bridge PCES worksheet)

Comments - Constr. Engr. Br. #1:

Comments - Misc. P.E. Bridge #1:

Bridge Job #

Federal Structure ID

Manual CEI Cost Override :

Bridge # 2 CEI Cost :

15.0%

Manual PE Cost Adjustment :

Bridge #2 CN + CEI Cost :

P.E. Bridge # 2

BRIDGE #2 CN Cost : (input from Bridge PCES worksheet)

Comments - Constr. Engr. Br. #2:

Comments - Misc. P.E. Bridge #2:

Bridge Job #

Federal Structure ID

Manual CEI Cost Override :

Bridge # 3 CEI Cost :   
15.0%

Manual PE Cost Adjustment :

BRIDGE #3 CN Cost : (input from Bridge PCES worksheet)

Bridge #3 CN + CEI Cost :

P.E. Bridge # 3

Comments - Constr. Engr. Br. #3:

Comments - Misc. P.E. Bridge #3:

BRIDGE CONSTRUCTION AND PE COSTS (continued)

**BRIDGE  
CONSTRUCTION**

**BRIDGE  
P. E.**

Bridge Job #

Federal Structure ID

Manual CEI Cost Override :

Bridge # 4 CEI Cost :

\$275,100

15.0%

Manual PE Cost Adjustment :

Bridge #4 CN + CEI Cost :

\$2,109,100

P.E. Bridge # 4

BRIDGE #4 CN Cost : (input from Bridge PCES worksheet)

\$1,834,000

\$178,872

Comments - Constr. Engr. Br. #4:

Comments - Misc. P.E. Bridge #4:

Bridge Job #

Federal Structure ID

Manual CEI Cost Override :

Bridge # 5 CEI Cost :

\$366,795

13.5%

Manual PE Cost Adjustment :

Bridge #5 CN + CEI Cost :

\$3,083,795

P.E. Bridge # 5

BRIDGE #5 CN Cost : (input from Bridge PCES worksheet)

\$2,717,000

\$206,643

Comments - Constr. Engr. Br. #5:

Comments - Misc. P.E. Bridge #5:

Bridge Job #

Federal Structure ID

Manual CEI Cost Override :

Bridge # 6 CEI Cost :

13.5%

Manual PE Cost Adjustment :

BRIDGE #6 CN Cost : (input from Bridge PCES worksheet)

Bridge #6 CN + CEI Cost :

P.E. Bridge # 6

Comments - Constr. Engr. Br. #6:

Comments - Misc. P.E. Bridge #6:

BRIDGE CONSTRUCTION AND PE COSTS (continued)

BRIDGE  
CONSTRUCTION

BRIDGE  
P. E.

Bridge Job #

Federal Structure ID

Manual CEI Cost Override :

Bridge # 7 CEI Cost :

11.0%

Manual PE Cost Adjustment :

Bridge #7 CN + CEI Cost :

P.E. Bridge # 7

BRIDGE #7 CN Cost : (input from Bridge PCES worksheet)



Comments - Constr. Engr. Br. #7:

Comments - Misc. P.E. Bridge #7:

Bridge Job #

Federal Structure ID

Manual CEI Cost Override :

Bridge # 8 CEI Cost :

15.0%

Manual PE Cost Adjustment :

Bridge #8 CN + CEI Cost :

P.E. Bridge # 8

BRIDGE #8 CN Cost : (input from Bridge PCES worksheet)



Comments - Constr. Engr. Br. #8:

Comments - Misc. P.E. Bridge #8:

Bridge Job #

Federal Structure ID

Manual CEI Cost Override :



Bridge # 9 CEI Cost :

\$338,660

14.0%

Manual PE Cost Adjustment :

BRIDGE #9 CN Cost : (input from Bridge PCES worksheet)

\$2,419,000

Bridge #9 CN + CEI Cost :

\$2,757,660

P.E. Bridge # 9

\$197,271

Comments - Constr. Engr. Br. #9:

Comments - Misc. P.E. Bridge #9:

BRIDGE CONSTRUCTION AND PE COSTS (continued)

BRIDGE  
CONSTRUCTION

BRIDGE  
P. E.

Bridge Job #

Federal Structure ID

Manual CEI Cost Override :

Bridge # 10 CEI Cost :

11.0%

Manual PE Cost Adjustment :

Bridge #10 CN + CEI Cost :

P.E. Bridge # 10

BRIDGE #10 CN Cost : (input from Bridge PCES worksheet)



Comments - Constr. Engr. Br. #10:

Comments - Misc. P.E. Bridge #10:

Bridge Job #

Federal Structure ID

Manual CEI Cost Override :

Bridge # 11 CEI Cost :

15.0%

Manual PE Cost Adjustment :

Bridge #11 CN + CEI Cost :

P.E. Bridge # 11

BRIDGE #11 CN Cost : (input from Bridge PCES worksheet)



Comments - Constr. Engr. Br. #11:

Comments - Misc. P.E. Bridge #11:

Bridge Job #

Federal Structure ID

Manual CEI Cost Override :

Bridge # 12 CEI Cost : \$34,380  
*18.0%*

Manual PE Cost Adjustment :  

BRIDGE #12 CN Cost : (input from Bridge PCES worksheet) \$191,000

Bridge #12 CN + CEI Cost : \$225,380



P.E. Bridge # 12 \$62,075

Comments - Constr. Engr. Br. #12:

Comments - Misc. P.E. Bridge #12:

BRIDGE CONSTRUCTION AND PE COSTS (continued)			
		<i>Bridge Construction Base (PCES)</i>	\$40,918,000
<i>Bike / PED Construction Cost</i>	\$0		
<i>Bike / PED CE</i>	\$0	<i>Bridge Removal</i>	\$0
<i>Bike / PED PE</i>	\$0	<i>Bridge CE (PCES)</i>	\$5,138,495
<b>NOTE : Structure Complexity is based upon Height,</b>		<b>Bridge Estimate. (2016)</b>	<b>\$46,056,495</b>
<b>Difficulty of Construction, and other Factors</b>		<b>Total Bridge P. E. Costs (PCES)</b>	<b>\$2,676,062</b>

Version 6.00

 Project Cost Estimating System COMMENTS 		
General / Miscellaneous Comments from CONST, RW, & UTILITY Worksheets	Team Member and Section	Date Entered
1 Project terrain changed from rolling to level based on comments from L&D on draft cost estimate	C. Sutkowski - HRCS Team	06/23/16
2 Moved 10% of roadway and structures costs for general utility relocation from CONST-MISC sheet to MANUAL sheet	C. Sutkowski - HRCS Team	06/27/16
3 Input revised bridge costs based on comments from S&B on draft cost estimate	C. Sutkowski - HRCS Team	06/28/16
4 Included costs for noise barriers in segment estimate as provided by noise team	C. Sutkowski - HRCS Team	06/29/16
5 Updated costs for right-of-way with contingency added in line item in MANUAL sheet	C. Sutkowski - HRCS Team	06/29/16
6 Added costs for right-of-way for stormwater management in MANUAL sheet	C. Sutkowski - HRCS Team	06/29/16
7		
8		
9		
10		
11		
12		
13		
14		
15		

**VDOT Project Cost Estimating System  
MANUAL ESTIMATE**

	DATE	PE	RW	CN
<b>EXPENDITURES</b>	01/20/16	\$839,552		\$0
<b>RUMS</b>	01/28/16			\$0
<b>TRNS*PORT</b>				\$0
<b>AWARD</b>	01/28/16			\$0
<b>PROJECTION</b>	01/28/16			\$0

**ESTIMATE YEAR**

**AD YEAR**

FY2016		FY2016
\$0	PE	\$0
\$7,407,544	RW	\$7,407,544
\$0	CN	\$0
\$7,407,544	<b>TOTAL</b>	\$7,407,544

Job #	Phase	Comment	Estimate
	RW	10% of roadway and structures costs for general utility relocation	\$6,913,312
	RW	Cost for utility work under RW project. See file Utilities Cost Estimate All Segments(AWP).xls	\$34,474
	RW	Cost for Right-of-Way. See file HRCS ROW Costs.xlsx	\$269,287
	RW	Cost for Right-of-Way for Stormwater Management. See file HRCS ROW Costs.xlsx	\$190,471

Job #	Phase	Comment	Estimate
-------	-------	---------	----------



## Project Cost Estimating System SUMMARY PAGE

<b>DISTRICT</b>	<b>HAMPTON ROADS</b>		
<b>PROJECT NUMBER</b>	<b>64965081</b>		
<b>CONSTRUCTION END YEAR</b>	<b>FY2016</b>	<b>UPC</b>	<b>106724</b>
<b>AD YEAR</b>	<b>FY2016</b>	RATE OF INFLATION TO AD	<b>N/A</b>
<b>ESTIMATE YEAR</b>	<b>FY2016</b>	INFLATION RATE DURING CN	<b>N/A</b>
Date of previous estimate	01/28/16		
<b>PROJECT MANAGER / DESIGNER</b>	<b>Scott.Smizik</b>		
Preliminary Engineering Estimate:	<b>PCES</b>		
Construction Estimate:	<b>PCES</b>		
Right-of-Way Estimate:	<b>MANUAL</b>		
Utilities Estimate:	<b>MANUAL</b>		
<b>DATE</b>	<b>6/30/2016</b>		

THE FOLLOWING DATA WILL BE PROVIDED UPON COMPLETION OF THE REMAINDER OF THE WORKBOOK, WHICH IS ACCESSED BY SELECTING THE CONST, RW, & UTIL TABS BELOW



<b>CONSTRUCTION ESTIMATE</b>	<b>\$368,697,088</b>
<b>PRELIMINARY ENGINEERING ESTIMATE</b>	<b>\$16,771,219</b>
<b>RIGHT-OF-WAY &amp; UTILITIES ESTIMATE</b>	<b>\$38,069,282</b>
<b>TOTAL PROJECT ESTIMATE</b>	<b>\$423,537,589</b>

© Virginia Department of Transportation 2005

Revised 01/21/16

Estimate Class: Blank

Version 6.00

	Project Cost Estimating System CONSTRUCTION / BRIDGE / PE	
---	--	---

Project No. **64965081**

Interstate Project ?

Route Number   **Interstate Highway**

	CONST-1	CONST-2	Bridges (0)	Total
Geometric Standard	GS-5			
Construction Base	\$79,926,314	\$0	\$250,966,000	\$330,892,314
Bridge Removal			\$0	\$0
CE	\$9,990,789		\$27,813,985	\$37,804,774
Construction Estimate (2016)	\$89,917,103		\$278,779,985	\$368,697,088
To AdYear Inflation				\$0
Mid-point construction Inflation				\$0
Total Construction Estimate			\$278,779,985	<b>\$368,697,088</b>
Preliminary Engineering Cost	\$8,272,373		\$8,498,846	\$16,771,219

### CONSTRUCTION & PE TOTALS

<p><b>Total Construction Estimate</b> (Roadway plus Bridge)</p>	<p><b>\$368,697,088</b></p>	<p><b>PCES</b></p>
<p><b>Total Preliminary Engineering Estimate</b> (Roadway plus Bridge)</p>	<p><b>\$16,771,219</b></p>	<p><b>PCES</b></p>



Project Cost Estimating System

CONSTRUCTION / BRIDGE / PE

Project No. **64965081**

Interstate Project ?	<input type="text" value="Yes"/>	*									
Maintenance Project ?	<input type="text" value="No"/>	*									
Route Number	<input type="text" value="664"/>	*	Interstate Highway								
Select INTERSTATE >	<input type="text" value="GS-5"/>	*	Principal Arterial - Freeway								
Ad Date	<input type="text" value="2016"/>		Design Year = 2038								
Design Year ADT	<input type="text" value="61,600"/>	*	Project Terrain <input type="text" value="Level"/>								
<i>Box Must Be Empty</i>	<input type="text"/>		Approx. DHV = 9,240								
Enter Design Speed (MPH) (Enter 60 or 70)	<input type="text" value="70"/>	*	Minimum Design Speed = 70 MPH								
<i>Box Must Be Empty</i>	<input type="text"/>										
<i>Box Must Be Empty</i>	<input type="text"/>										
Project Length (mi.)	<input type="text" value="3.81"/>	*									
Total Length - Adding or Building <b>Two Lanes</b> (mi.)	<input type="text" value="0.33"/>	*	<table border="0" style="width: 100%;"> <tr> <td style="text-align: center;"><i>Number of Additional Lanes:</i></td> <td style="text-align: center;"><i>Length of Add'l. Lanes (mi.):</i></td> </tr> <tr> <td style="text-align: center;"><b>+ One Add'l. Lane</b></td> <td style="text-align: center;"><input type="text" value="0.57"/></td> </tr> <tr> <td style="text-align: center;"><b>+ Two Add'l. Lanes</b></td> <td style="text-align: center;"><input type="text" value="0.50"/></td> </tr> <tr> <td style="text-align: center;"><b>None</b></td> <td style="text-align: center;"><input type="text"/></td> </tr> </table>	<i>Number of Additional Lanes:</i>	<i>Length of Add'l. Lanes (mi.):</i>	<b>+ One Add'l. Lane</b>	<input type="text" value="0.57"/>	<b>+ Two Add'l. Lanes</b>	<input type="text" value="0.50"/>	<b>None</b>	<input type="text"/>
<i>Number of Additional Lanes:</i>	<i>Length of Add'l. Lanes (mi.):</i>										
<b>+ One Add'l. Lane</b>	<input type="text" value="0.57"/>										
<b>+ Two Add'l. Lanes</b>	<input type="text" value="0.50"/>										
<b>None</b>	<input type="text"/>										
Total Length - Adding or Building <b>Four Lanes</b> (mi.)	<input type="text" value="1.88"/>	*									
Total Length - Building <b>Ramps and Loops</b> (mi.)	<input type="text"/>	*									
Shoulder or Curb & Gutter ? (Select S or C&G)	<input type="text" value="S"/>	*	Enter Lane Width (ft) > <input type="text"/>								
Median Type - Graded, Raised, or None ?	<input type="text" value="G"/>	*	Normal Lane Width(ft) <input type="text" value="12"/>								
Number of Crossovers (Divided Highways ONLY)	<input type="text"/>	*									
Length - Curb & Gutter - Left PLUS Right Side (ft.)	<input type="text"/>										
Length - Sidewalk - Left PLUS Right Side (ft.)	<input type="text"/>										
<b>Bike / Pedestrian Type</b>	<input type="text" value="None"/>										
Total Length - Raised Median (ft.)	<input type="text"/>										
Number of <b>Right Turn Lanes</b> - Left PLUS Right Side	<input type="text"/>	*									
Number of <b>Left Turn Lanes</b> - (Undivided Only)	<input type="text"/>	*									

**HAMPTON ROADS**  
 110% Cost Factor used  
**Construction Costs**

Signals, ITS, Signs and Lighting Costs*	<input type="text" value="\$6,193,968"/>		Base #1 (PCES)	<input type="text" value="\$79,926,314"/>
Cost of Large Drainage Structures	<input type="text" value="\$0"/>		Base #2	<input type="text" value="\$0"/>
In-Plan Utility Costs*	<input type="text" value="\$0"/>		Enter Const CE Cost >	<input type="text" value="\$0"/>
Adjustment for Unusual Construction Costs	<input type="text" value="\$52,279,136"/>		CE (12.5%)	<input type="text" value="\$9,990,789"/>
<i>* Totals include district factor calculations</i>			Estimate (2016)	<input type="text" value="\$89,917,103"/>

Additional (or Unusual) P. E. Costs	<input type="text"/>	
Select % of PE to be performed by Consultants	<input type="text" value="30%"/>	PE Cost (PCES) <input type="text" value="\$8,272,373"/>

**Note: Do Not Include Bridge P. E. Costs Here**

Roadway P. E. / Roadway Const. = 9.2%

© Virginia Department of Transportation 2005  
Revised 01/21/16

**Today's Date: 06/30/16**

**Version 6.00**

**Project Cost Estimating System**   
**Miscellaneous Cost Estimates**

**COST OF LARGE DRAINAGE STRUCTURES**

Job#	Description	Cost ( )
		<b>\$0</b>

**ADJUSTMENT FOR UNUSUAL CONSTRUCTION COSTS**

Type	Description	Cost ( )
Maintenance of Traffic	20% of roadway costs for MOT	\$6,135,673
Other	5% of roadway and structures costs for landscaping	\$14,082,218
Other	Resurfacing existing roadways	\$2,838,719
Other	Excessive excavation	\$0
Other	Excessive borrow	\$0
Other	Concrete barrier	\$1,927,967
Other	Guardrail and end treatments	\$1,808,626
Other	Removal of existing guardrail	\$41,467
Other	Demolition of existing pavement	\$252,700
Other	Noise barriers	\$0
Other	Retaining walls	\$0
Other	Tunnel costs	\$0
Other	Major in-plan utility work (water and sanitary sewer)	\$51,600
Other	Wet ponds and bioretention facilities	\$975,000
Environmental	Wetland and stream impacts	\$329,075
Environmental	Historic and archaeological resources	\$1,000,000
Other	40% contingency added to base construction cost	\$22,836,090
		<b>\$52,279,136</b>

Version 6.00

**SIGNALS, ITS, SIGNS and LIGHTING COST WORKSHEET**

Stand Alone Traffic Project:  No

UPC: 106724

**SIGNALS**

Permanent Signals	New/Mod.	Intersection Type	Major				Cross				Poles	Detection	Pre-emption	Cost
			Direction	Lanes	Direction	Lanes	Direction	Lanes	Direction	Lanes				
Location/Description														
1														\$0
2														\$0
3														\$0
4														\$0
5														\$0
6														\$0
7														\$0
8														\$0
9														\$0
10														\$0

Temporary Signals - New Equipment	Quantity	Cost
Temporary Signals - Modified Equipment		\$0

MISCELLANEOUS SIGNAL WORK	Location/Description	Cost
1		
2		
<b>Signals Construction Subtotal</b>		<b>\$0</b>

ITS	Location/Description	Cost
ITS WORK 1		
2		
<b>ITS Construction Subtotal</b>		<b>\$0</b>

MAJOR SIGN STRUCTURES		Quantity	Unit	Lighted Y/N	Included in Roadway Lighting? yes/no	Cost/Sign	Extended Cost
1	O/H Span (50-100)	10	Ea.	Yes		114,319	\$1,143,186
2	O/H Span (101-200)	3	Ea.	Yes		203,066	\$609,199
3	O/H Span (50-100)	5	Ea.	No		112,819	\$564,093
4			Ea.				
5			Ea.				
6			Ea.				
7			Ea.				
MISCELLANEOUS 1 SIGN WORK		Location/Description				Cost	
1	Add mile post markers at \$1,000/mile for 3.80 miles				\$3,800		
2							
<b>Signs Construction Subtotal</b>					<b>\$2,320,279</b>		

LIGHTING				Number of Miles	Cost
<b>Continuous Roadway</b>					
Urban Type of Lighting	Comments	No. Lanes			
1					\$0
Freeway Type of Lighting	Comments	No. Lanes			
1	Conventional	8		3.80	\$3,310,601
<b>Interchange</b>					
Interchange Type	Type of Lighting			Number of Interchanges	Cost
1					\$0
2					\$0
3					\$0
<b>Miscellaneous</b>					
	Location/Description				Cost
1					
2					
<b>Lighting Construction Subtotal</b>					<b>\$3,310,601</b>
<b>CONSTRUCTION TOTAL</b>					<b>\$5,630,880</b>

*District factor will be applied when the total cost is passed to the const-1 worksheet*

**PROJECT COMMENTS**

Prepared by: CMS

Date Prepared/Modified: 05/05/16

Version 6.00

# BRIDGE CONSTRUCTION AND PRELIMINARY ENGINEERING COSTS

BRIDGE  
CONSTRUCTION

BRIDGE  
P. E.

Bridge Job #

Federal Structure ID

Manual CEI Cost Override :

Bridge # 1 CEI Cost :

14%

Manual PE Cost Adjustment :

Bridge #1 CN + CEI Cost :

P.E. Bridge # 1

BRIDGE #1 CN Cost : (input from Bridge PCES worksheet)

Comments - Constr. Engr. Br. #1:

Comments - Misc. P.E. Bridge #1:

Bridge Job #

Federal Structure ID

Manual CEI Cost Override :

Bridge # 2 CEI Cost :

11.0%

Manual PE Cost Adjustment :

Bridge #2 CN + CEI Cost :

P.E. Bridge # 2

BRIDGE #2 CN Cost : (input from Bridge PCES worksheet)

Comments - Constr. Engr. Br. #2:

Comments - Misc. P.E. Bridge #2:

Bridge Job #

Federal Structure ID

Manual CEI Cost Override :

Bridge # 3 CEI Cost :   
13.5%

Manual PE Cost Adjustment :

BRIDGE #3 CN Cost : (input from Bridge PCES worksheet)

Bridge #3 CN + CEI Cost :

P.E. Bridge # 3

Comments - Constr. Engr. Br. #3:

Comments - Misc. P.E. Bridge #3:

BRIDGE CONSTRUCTION AND PE COSTS (continued)

**BRIDGE  
CONSTRUCTION**

**BRIDGE  
P. E.**

Bridge Job #

Federal Structure ID

Manual CEI Cost Override :

Bridge # 4 CEI Cost :

13.5%

Manual PE Cost Adjustment :

Bridge #4 CN + CEI Cost :

P.E. Bridge # 4

BRIDGE #4 CN Cost : (input from Bridge PCES worksheet)

Comments - Constr. Engr. Br. #4:

Comments - Misc. P.E. Bridge #4:

Bridge Job #

Federal Structure ID

Manual CEI Cost Override :

Bridge # 5 CEI Cost :

11.0%

Manual PE Cost Adjustment :

Bridge #5 CN + CEI Cost :

P.E. Bridge # 5

BRIDGE #5 CN Cost : (input from Bridge PCES worksheet)

Comments - Constr. Engr. Br. #5:

Comments - Misc. P.E. Bridge #5:

Bridge Job #

Federal Structure ID

Manual CEI Cost Override :

Bridge # 6 CEI Cost :

\$0

18.0%

Manual PE Cost Adjustment :

--

BRIDGE #6 CN Cost : (input from Bridge PCES worksheet)

--

Bridge #6 CN + CEI Cost :

\$0
-----

P.E. Bridge # 6

\$0
-----

Comments - Constr. Engr. Br. #6:



--

Comments - Misc. P.E. Bridge #6:

--



BRIDGE CONSTRUCTION AND PE COSTS (continued)			
		<i>Bridge Construction Base (PCES)</i>	\$250,966,000
<i>Bike / PED Construction Cost</i>	\$0		
<i>Bike / PED CE</i>	\$0	<i>Bridge Removal</i>	\$0
<i>Bike / PED PE</i>	\$0	<i>Bridge CE (PCES)</i>	\$27,813,985
<b>NOTE : Structure Complexity is based upon Height,</b>		<b>Bridge Estimate. (2016)</b>	<b>\$278,779,985</b>
<b>Difficulty of Construction, and other Factors</b>		<b>Total Bridge P. E. Costs (PCES)</b>	<b>\$8,498,846</b>
			<b>Version 6.00</b>

 <b>Project Cost Estimating System</b> <b>COMMENTS</b> 		
<b>General / Miscellaneous Comments from CONST, RW, &amp; UTILITY Worksheets</b>	<b>Team Member and Section</b>	<b>Date Entered</b>
<b>1</b> Project terrain changed from rolling to level based on comments from L&D on draft cost estimate	C. Sutkowski - HRCS Team	06/23/16
<b>2</b> Moved 10% of roadway and structures costs for general utility relocation from CONST-MISC sheet to MANUAL sheet	C. Sutkowski - HRCS Team	06/27/16
<b>3</b> Input revised bridge costs based on comments from S&B on draft cost estimate	C. Sutkowski - HRCS Team	06/28/16
<b>4</b> Included costs for noise barriers in segment estimate as provided by noise team	C. Sutkowski - HRCS Team	06/29/16
<b>5</b> Updated costs for right-of-way with contingency added in line item in MANUAL sheet	C. Sutkowski - HRCS Team	06/29/16
<b>6</b> Added costs for right-of-way for stormwater management in MANUAL sheet	C. Sutkowski - HRCS Team	06/29/16
<b>7</b>		
<b>8</b>		
<b>9</b>		
<b>10</b>		
<b>11</b>		
<b>12</b>		
<b>13</b>		
<b>14</b>		
<b>15</b>		

UPC: 106724

**VDOT Project Cost Estimating System  
MANUAL ESTIMATE**

	DATE	PE	RW	CN
<b>EXPENDITURES</b>	01/20/16	\$839,552		\$0
<b>RUMS</b>	01/28/16			\$0
<b>TRNS*PORT</b>				\$0
<b>AWARD</b>	01/28/16			\$0
<b>PROJECTION</b>	01/28/16			\$0

**ESTIMATE YEAR**

**AD YEAR**

FY2016		FY2016
\$0	PE	\$0
\$38,069,282	RW	\$38,069,282
\$0	CN	\$0
\$38,069,282	<b>TOTAL</b>	\$38,069,282

Job #	Phase	Comment	Estimate
	RW	10% of roadway and structures costs for general utility relocation	\$28,164,437
	RW	Cost for utility work under RW project. See file Utilities Cost Estimate All Segments(AWP).xls	\$416,861
	RW	Cost for Right-of-Way. See file HRCS ROW Costs.xlsx	\$9,146,450
	RW	Cost for Right-of-Way for Stormwater Management. See file HRCS ROW Costs.xlsx	\$341,535

Job #	Phase	Comment	Estimate
-------	-------	---------	----------



## Project Cost Estimating System SUMMARY PAGE

DISTRICT	<b>HAMPTON ROADS</b>		
PROJECT NUMBER	<b>64965081</b>		
CONSTRUCTION END YEAR	<b>FY2016</b>	UPC	<b>106724</b>
AD YEAR	<b>FY2016</b>	RATE OF INFLATION TO AD	<b>N/A</b>
ESTIMATE YEAR	<b>FY2016</b>	INFLATION RATE DURING CN	<b>N/A</b>
Date of previous estimate	01/28/16		
PROJECT MANAGER / DESIGNER	<b>Scott.Smizik</b>		
Preliminary Engineering Estimate:	<b>PCES</b>		
Construction Estimate:	<b>PCES</b>		
Right-of-Way Estimate:	<b>MANUAL</b>		
Utilities Estimate:	<b>MANUAL</b>		
DATE	<b>6/30/2016</b>		

THE FOLLOWING DATA WILL BE PROVIDED UPON COMPLETION OF THE REMAINDER OF THE WORKBOOK, WHICH IS ACCESSED BY SELECTING THE CONST, RW, & UTIL TABS BELOW



CONSTRUCTION ESTIMATE	<b>\$3,539,420,549</b>
PRELIMINARY ENGINEERING ESTIMATE	<b>\$325,626,691</b>
RIGHT-OF-WAY & UTILITIES ESTIMATE	<b>\$6,420,839</b>
TOTAL PROJECT ESTIMATE	<b>\$3,871,468,079</b>

© Virginia Department of Transportation 2005

Revised 01/21/16

Estimate Class: Blank

Version 6.00

	Project Cost Estimating System CONSTRUCTION / BRIDGE / PE	
---	--	---

Project No. **64965081**

Interstate Project ?

Route Number   **Interstate Highway**

	CONST-1	CONST-2	Bridges (0)	Total
Geometric Standard	GS-5			
Construction Base	\$3,146,151,599	\$0	\$0	\$3,146,151,599
Bridge Removal			\$0	\$0
CE	\$393,268,950		\$0	\$393,268,950
Construction Estimate (2016)	\$3,539,420,549		\$0	\$3,539,420,549
To AdYear Inflation				\$0
Mid-point construction Inflation				\$0
Total Construction Estimate			\$0	<b>\$3,539,420,549</b>
Preliminary Engineering Cost	\$325,626,691		\$0	\$325,626,691

### CONSTRUCTION & PE TOTALS

Total Construction Estimate **\$3,539,420,549** **PCES**  
 (Roadway plus Bridge)

Total Preliminary Engineering Estimate **\$325,626,691** **PCES**  
 (Roadway plus Bridge)

Project Cost Estimating System

CONSTRUCTION / BRIDGE / PE

Project No. **64965081**

Interstate Project ?	<input type="text" value="Yes"/>	*			
Maintenance Project ?	<input type="text" value="No"/>	*			
Route Number	<input type="text" value="664"/>	*	Interstate Highway		
Select INTERSTATE >	<input type="text" value="GS-5"/>	*	Principal Arterial - Freeway		
Ad Date	<input type="text" value="2016"/>		Design Year = 2038		
Design Year ADT	<input type="text" value="64,400"/>	*	Project Terrain <input type="text" value="Level"/>		
<i>Box Must Be Empty</i>	<input type="text"/>		Approx. DHV = 9,660		
Enter Design Speed (MPH) (Enter 60 or 70)	<input type="text" value="70"/>	*	Minimum Design Speed = 70 MPH		
<i>Box Must Be Empty</i>	<input type="text"/>				
<i>Box Must Be Empty</i>	<input type="text"/>				
Project Length (mi.)	<input type="text" value="1.59"/>	*	<table border="0" style="margin: 0 auto;"> <tr> <td style="text-align: center;"><i>Number of Additional Lanes:</i></td> <td style="text-align: center;"><i>Length of Add'l. Lanes (mi.):</i></td> </tr> </table>	<i>Number of Additional Lanes:</i>	<i>Length of Add'l. Lanes (mi.):</i>
<i>Number of Additional Lanes:</i>	<i>Length of Add'l. Lanes (mi.):</i>				
Total Length - Adding or Building <u>Two Lanes</u> (mi.)	<input type="text" value="0.50"/>	*	<input type="text"/>		
Total Length - Adding or Building <u>Four Lanes</u> (mi.)	<input type="text" value="0.51"/>	*	<input type="text" value="None"/>		
Total Length - Building <u>Ramps and Loops</u> (mi.)	<input type="text"/>	*	<input type="text" value="None"/>		
Shoulder or Curb & Gutter ? (Select S or C&G)	<input type="text"/>	*	Enter Lane Width (ft) > <input type="text"/>		
Median Type - Graded, Raised, or None ?	<input type="text"/>	*	Normal Lane Width(ft) <input type="text" value="12"/>		
Number of Crossovers (Divided Highways ONLY)	<input type="text"/>	*			
Length - Curb & Gutter - Left PLUS Right Side (ft.)	<input type="text"/>				
Length - Sidewalk - Left PLUS Right Side (ft.)	<input type="text"/>				
Bike / Pedestrian Type	<input type="text" value="None"/>				
Total Length - Raised Median (ft.)	<input type="text"/>				
Number of <u>Right Turn Lanes</u> - Left PLUS Right Side	<input type="text"/>	*			
Number of Left Turn Lanes - (Undivided Only)	<input type="text"/>	*			

**HAMPTON ROADS**  
 110% Cost Factor used  
**Construction Costs**

Signals, ITS, Signs and Lighting Costs*	<input type="text" value="\$446,746"/>		Base #1 (PCES)	<input type="text" value="\$3,146,151,599"/>
Cost of Large Drainage Structures	<input type="text" value="\$0"/>		Base #2	<input type="text" value="\$0"/>
In-Plan Utility Costs*	<input type="text" value="\$0"/>		Enter Const CE Cost >	<input type="text" value="\$0"/>
Adjustment for Unusual Construction Costs	<input type="text" value="\$3,138,391,143"/>		CE (12.5%)	<input type="text" value="\$393,268,950"/>
<i>* Totals include district factor calculations</i>			Estimate (2016)	<input type="text" value="\$3,539,420,549"/>

Additional (or Unusual) P. E. Costs	<input type="text"/>	
Select % of PE to be performed by Consultants	<input type="text" value="30%"/>	PE Cost (PCES) <input type="text" value="\$325,626,691"/>



**Note: Do Not Include Bridge P. E. Costs Here**

Roadway P. E. / Roadway Const. = 9.2%

© Virginia Department of Transportation 2005  
Revised 01/21/16

**Today's Date: 06/30/16**

**Version 6.00**

	<b>Project Cost Estimating System</b> Miscellaneous Cost Estimates	
---	---	---

**COST OF LARGE DRAINAGE STRUCTURES**

Job#	Description	Cost ()
		<b>\$0</b>

**ADJUSTMENT FOR UNUSUAL CONSTRUCTION COSTS**

Type	Description	Cost ()
Maintenance of Traffic	5% of roadway costs for MOT	\$390,686
Other	Eliminated costs for landscaping	\$0
Other	Resurfacing existing roadways	\$0
Other	Excessive excavation	\$0
Other	Excessive borrow	\$0
Other	Concrete barrier	\$0
Other	Guardrail and end treatments	\$0
Other	Removal of existing guardrail	\$0
Other	Demolition of existing pavement	\$0
Other	Noise barriers	\$0
Other	Retaining walls	\$0
Other	Tunnel costs	\$2,238,600,000
Other	Major in-plan utility work (water and sanitary sewer)	\$0
Other	Wet ponds and bioretention facilities	\$0
Environmental	Wetland and stream impacts	\$0
Environmental	Historic and archaeological resources	\$500,000
Other	40% contingency added to base construction cost	\$898,900,457
		<b>\$3,138,391,143</b>

Version 6.00



**SIGNALS, ITS, SIGNS and LIGHTING COST WORKSHEET**

Stand Alone Traffic Project:  No

UPC: 106724

**SIGNALS**

Permanent Signals	New/Mod.	Intersection Type	Major				Cross				Poles	Detection	Pre-emption	Cost
			Direction	Lanes	Direction	Lanes	Direction	Lanes	Direction	Lanes				
Location/Description														
1														\$0
2														\$0
3														\$0
4														\$0
5														\$0
6														\$0
7														\$0
8														\$0
9														\$0
10														\$0

Temporary Signals - New Equipment	Quantity	Cost
Temporary Signals - Modified Equipment		\$0

MISCELLANEOUS SIGNAL WORK	Location/Description	Cost
1		
2		

Signals Construction Subtotal \$0

**ITS**

ITS WORK	Location/Description	Cost
1		
2		

ITS Construction Subtotal \$0

**MAJOR SIGN STRUCTURES**

Type of Sign	Comment	Quantity	Unit	Lighted Y/N	Included in Roadway Lighting? yes/no	Cost/Sign	Extended Cost
1 O/H Span (101-200)	Signs at ends of tunnel	2	Ea.	Yes		203,066	\$406,133
2			Ea.				
3			Ea.				
4			Ea.				
5			Ea.				
6			Ea.				
7			Ea.				

MISCELLANEOUS 1 SIGN WORK	Location/Description	Cost
1		
2		

Signs Construction Subtotal \$406,133

**LIGHTING**

Continuous Roadway		Comments		No. Lanes	Number of Miles	Cost
1	Urban Type of Lighting					\$0
1	Freeway Type of Lighting					\$0
Interchange		Type of Lighting		Number of Interchanges		Cost
1	Interchange Type					\$0
2						\$0
3						\$0
Miscellaneous		Location/Description				Cost
1						
2						

Lighting Construction Subtotal \$0

**CONSTRUCTION TOTAL \$406,133**

*District factor will be applied when the total cost is passed to the const-1 worksheet*

**PROJECT COMMENTS**

Prepared by: CMS

Date Prepared/Modified: 05/05/16

Version 6.00

# BRIDGE CONSTRUCTION AND PRELIMINARY ENGINEERING COSTS

BRIDGE  
CONSTRUCTION

BRIDGE  
P. E.

Bridge Job #

Federal Structure ID

Manual CEI Cost Override :

Bridge # 1 CEI Cost :  18%

Manual PE Cost Adjustment :

Bridge #1 CN + CEI Cost :

P.E. Bridge # 1

BRIDGE #1 CN Cost : (input from Bridge PCES worksheet)

Comments - Constr. Engr. Br. #1:

Comments - Misc. P.E. Bridge #1:

Bridge Job #

Federal Structure ID

Manual CEI Cost Override :

Bridge # 2 CEI Cost :  18.0%

Manual PE Cost Adjustment :

Bridge #2 CN + CEI Cost :

P.E. Bridge # 2

BRIDGE #2 CN Cost : (input from Bridge PCES worksheet)

Comments - Constr. Engr. Br. #2:



Comments - Misc. P.E. Bridge #2:

Bridge Job #

Federal Structure ID

BRIDGE CONSTRUCTION AND PE COSTS (continued)				
	<i>Bike / PED Construction Cost</i>	\$0	<i>Bridge Construction Base (PCES)</i>	\$0
	<i>Bike / PED CE</i>	\$0	<i>Bridge Removal</i>	\$0
	<i>Bike / PED PE</i>	\$0	<i>Bridge CE (PCES)</i>	\$0
<b>NOTE : Structure Complexity is based upon Height,</b>			<b>Bridge Estimate. (2016)</b>	<b>\$0</b>
<b>Difficulty of Construction, and other Factors</b>			<b>Total Bridge P. E. Costs (PCES)</b>	<b>\$0</b>

Version 6.00

 Project Cost Estimating System <b>COMMENTS</b> 		
<b>General / Miscellaneous Comments from CONST, RW, &amp; UTILITY Worksheets</b>	<b>Team Member and Section</b>	<b>Date Entered</b>
<b>1</b> Project terrain changed from rolling to level based on comments from L&D on draft cost estimate	C. Sutkowski - HRCS Team	06/23/16
<b>2</b> Moved 10% of roadway and structures costs for general utility relocation from CONST-MISC sheet to MANUAL sheet	C. Sutkowski - HRCS Team	06/27/16
<b>3</b> Included costs for noise barriers in segment estimate as provided by noise team	C. Sutkowski - HRCS Team	06/29/16
<b>4</b> Updated costs for right-of-way with contingency added in line item in MANUAL sheet	C. Sutkowski - HRCS Team	06/29/16
<b>5</b>		
<b>6</b>		
<b>7</b>		
<b>8</b>		
<b>9</b>		
<b>10</b>		
<b>11</b>		
<b>12</b>		
<b>13</b>		
<b>14</b>		
<b>15</b>		

**VDOT Project Cost Estimating System  
MANUAL ESTIMATE**

	DATE	PE	RW	CN
<b>EXPENDITURES</b>	01/20/16	\$839,552		\$0
<b>RUMS</b>	01/28/16			\$0
<b>TRNS*PORT</b>				\$0
<b>AWARD</b>	01/28/16			\$0
<b>PROJECTION</b>	01/28/16			\$0

**ESTIMATE YEAR**

**AD YEAR**

FY2016		FY2016
\$0	PE	\$0
\$6,420,839	RW	\$6,420,839
\$0	CN	\$0
\$6,420,839	<b>TOTAL</b>	\$6,420,839

Job #	Phase	Comment	Estimate
	RW	10% of roadway and structures costs for general utility relocation	\$781,371
	RW	Cost for utility work under RW project. See file Utilities Cost Estimate All Segments(AWP).xls	\$0
	RW	Cost for Right-of-Way. See file HRCS ROW Costs.xlsx	\$5,639,467
	RW	Cost for Right-of-Way for Stormwater Management. See file HRCS ROW Costs.xlsx	\$0

Job #	Phase	Comment	Estimate
-------	-------	---------	----------



## Project Cost Estimating System SUMMARY PAGE

<b>DISTRICT</b>	<b>HAMPTON ROADS</b>		
<b>PROJECT NUMBER</b>	<b>64965081</b>		
<b>CONSTRUCTION END YEAR</b>	<b>FY2016</b>	<b>UPC</b>	<b>106724</b>
<b>AD YEAR</b>	<b>FY2016</b>	<small>RATE OF INFLATION TO AD</small>	<b>N/A</b>
<b>ESTIMATE YEAR</b>	<b>FY2016</b>	<small>INFLATION RATE DURING CN</small>	<b>N/A</b>
<small>Date of previous estimate</small>	01/28/16		
<b>PROJECT MANAGER / DESIGNER</b>	<b>Scott.Smizik</b>		
<b>Preliminary Engineering Estimate:</b>	<b>PCES</b>		
<b>Construction Estimate:</b>	<b>PCES</b>		
<b>Right-of-Way Estimate:</b>	<b>MANUAL</b>		
<b>Utilities Estimate:</b>	<b>MANUAL</b>		
<b>DATE</b>	<b>6/30/2016</b>		

THE FOLLOWING DATA WILL BE PROVIDED UPON COMPLETION OF THE REMAINDER OF THE WORKBOOK, WHICH IS ACCESSED BY SELECTING THE CONST, RW, & UTIL TABS BELOW



<b>CONSTRUCTION ESTIMATE</b>	<b>\$2,245,544,255</b>
<b>PRELIMINARY ENGINEERING ESTIMATE</b>	<b>\$206,590,072</b>
<b>RIGHT-OF-WAY &amp; UTILITIES ESTIMATE</b>	<b>\$6,227,551</b>
<b>TOTAL PROJECT ESTIMATE</b>	<b>\$2,458,361,878</b>

© Virginia Department of Transportation 2005

Revised 01/21/16

Estimate Class: Blank

Version 6.00

	Project Cost Estimating System CONSTRUCTION / BRIDGE / PE	
---	--	---

Project No. **64965081**

Interstate Project ?

Route Number   **Interstate Highway**

	CONST-1	CONST-2	Bridges (0)	Total
Geometric Standard	GS-5			
Construction Base	\$1,996,039,338	\$0	\$0	\$1,996,039,338
Bridge Removal			\$0	\$0
CE	\$249,504,917		\$0	\$249,504,917
Construction Estimate (2016)	\$2,245,544,255		\$0	\$2,245,544,255
To AdYear Inflation				\$0
Mid-point construction Inflation				\$0
Total Construction Estimate			\$0	<b>\$2,245,544,255</b>
Preliminary Engineering Cost	\$206,590,072		\$0	\$206,590,072

### CONSTRUCTION & PE TOTALS

Total Construction Estimate <i>(Roadway plus Bridge)</i>	<b>\$2,245,544,255</b>	<b>PCES</b>
Total Preliminary Engineering Estimate <i>(Roadway plus Bridge)</i>	<b>\$206,590,072</b>	<b>PCES</b>

Project Cost Estimating System

CONSTRUCTION / BRIDGE / PE

Project No. **64965081**

Interstate Project ?	<input type="text" value="Yes"/>	*					
Maintenance Project ?	<input type="text" value="No"/>	*					
Route Number	<input type="text" value="664"/>	*	Interstate Highway				
Select INTERSTATE >	<input type="text" value="GS-5"/>	*	Principal Arterial - Freeway				
Ad Date	<input type="text" value="2016"/>		Design Year = 2038				
Design Year ADT	<input type="text" value="57,800"/>	*	Project Terrain <input type="text" value="Level"/>				
<i>Box Must Be Empty</i>	<input type="text"/>		Approx. DHV = 8,670				
Enter Design Speed (MPH) (Enter 60 or 70)	<input type="text" value="70"/>	*	Minimum Design Speed = 70 MPH				
<i>Box Must Be Empty</i>	<input type="text"/>						
<i>Box Must Be Empty</i>	<input type="text"/>						
Project Length (mi.)	<input type="text" value="1.59"/>	*	<table border="0" style="margin-left: auto; margin-right: auto;"> <tr> <td style="text-align: center;"><i>Number of Additional Lanes:</i></td> <td style="text-align: center;"><i>Length of Add'l. Lanes (mi.):</i></td> </tr> <tr> <td style="text-align: center;"><input type="text"/></td> <td style="text-align: center;"><input type="text"/></td> </tr> </table>	<i>Number of Additional Lanes:</i>	<i>Length of Add'l. Lanes (mi.):</i>	<input type="text"/>	<input type="text"/>
<i>Number of Additional Lanes:</i>	<i>Length of Add'l. Lanes (mi.):</i>						
<input type="text"/>	<input type="text"/>						
Total Length - Adding or Building <b>Two Lanes</b> (mi.)	<input type="text"/>	*	<input type="text"/>				
Total Length - Adding or Building <b>Four Lanes</b> (mi.)	<input type="text" value="0.51"/>	*	<input type="text" value="None"/>				
Total Length - Building <b>Ramps and Loops</b> (mi.)	<input type="text"/>	*	<input type="text" value="None"/>				
Shoulder or Curb & Gutter ? (Select S or C&G)	<input type="text"/>	*	Enter Lane Width (ft) > <input type="text"/>				
Median Type - Graded, Raised, or None ?	<input type="text"/>	*	Normal Lane Width(ft) <input type="text" value="12"/>				
Number of Crossovers (Divided Highways ONLY)	<input type="text"/>	*					
Length - Curb & Gutter - Left PLUS Right Side (ft.)	<input type="text"/>						
Length - Sidewalk - Left PLUS Right Side (ft.)	<input type="text"/>						
Bike / Pedestrian Type	<input type="text" value="None"/>						
Total Length - Raised Median (ft.)	<input type="text"/>						
Number of <b>Right Turn Lanes</b> - Left PLUS Right Side	<input type="text"/>	*					
Number of Left Turn Lanes - (Undivided Only)	<input type="text"/>	*					

**HAMPTON ROADS**  
 110% Cost Factor used

<b>Construction Costs</b>	
Base #1 (PCES)	<input type="text" value="\$1,996,039,338"/>
Base #2	<input type="text" value="\$0"/>
Enter Const CE Cost >	<input type="text" value="\$0"/>
CE (12.5%)	<input type="text" value="\$249,504,917"/>
Estimate (2016)	<input type="text" value="\$2,245,544,255"/>

Signals, ITS, Signs and Lighting Costs*	<input type="text" value="\$251,501"/>
Cost of Large Drainage Structures	<input type="text" value="\$0"/>
In-Plan Utility Costs*	<input type="text" value="\$0"/>
Adjustment for Unusual Construction Costs	<input type="text" value="\$1,990,106,044"/>

*\* Totals include district factor calculations*

Additional (or Unusual) P. E. Costs	<input type="text"/>	
Select % of PE to be performed by Consultants	<input type="text" value="30%"/>	PE Cost (PCES) <input type="text" value="\$206,590,072"/>





**Note: Do Not Include Bridge P. E. Costs Here**

Roadway P. E. / Roadway Const. = 9.2%

© Virginia Department of Transportation 2005  
Revised 01/21/16

**Today's Date: 06/30/16**

**Version 6.00**

**Project Cost Estimating System**  
**Miscellaneous Cost Estimates**

**COST OF LARGE DRAINAGE STRUCTURES**

Job#	Description	Cost ()
<input type="text"/>	<input type="text"/>	<input type="text"/>
<input type="text"/>	<input type="text"/>	<input type="text"/>
<input type="text"/>	<input type="text"/>	<input type="text"/>
<input type="text"/>	<input type="text"/>	<input type="text"/>
<input type="text"/>	<input type="text"/>	<input type="text"/>
		<b>\$0</b>

**ADJUSTMENT FOR UNUSUAL CONSTRUCTION COSTS**

Type	Description	Cost ()
Maintenance of Traffic	5% of roadway costs for MOT	\$309,090
Other	Eliminated costs for landscaping	\$0
Other	Resurfacing existing roadways	\$0
Other	Excessive excavation	\$0
Other	Excessive borrow	\$0
Other	Concrete barrier	\$0
Other	Guardrail and end treatments	\$0
Other	Removal of existing guardrail	\$0
Other	Demolition of existing pavement	\$0
Other	Noise barriers	\$0
Other	Retaining walls	\$0
Other	Tunnel costs	\$1,419,000,000
Other	Major in-plan utility work (water and sanitary sewer)	\$0
Other	Wet ponds and bioretention facilities	\$0
Environmental	Wetland and stream impacts	\$0
Environmental	Historic and archaeological resources	\$500,000
		<input type="text"/>
		<input type="text"/>
Other	40% contingency added to base construction cost	\$570,296,954
		<b>\$1,990,106,044</b>

Version 6.00

**SIGNALS, ITS, SIGNS and LIGHTING COST WORKSHEET**

Stand Alone Traffic Project:  No

UPC: 106724

**SIGNALS**

Permanent Signals	New/Mod.	Intersection Type	Major				Cross				Poles	Detection	Pre-emption	Cost
			Direction	Lanes	Direction	Lanes	Direction	Lanes	Direction	Lanes				
Location/Description														
1														\$0
2														\$0
3														\$0
4														\$0
5														\$0
6														\$0
7														\$0
8														\$0
9														\$0
10														\$0

Temporary Signals - New Equipment	Quantity	Cost
Temporary Signals - Modified Equipment		\$0

MISCELLANEOUS SIGNAL WORK	Location/Description	Cost
1		
2		

Signals Construction Subtotal \$0

**ITS**

ITS WORK	Location/Description	Cost
1		
2		

ITS Construction Subtotal \$0

**MAJOR SIGN STRUCTURES**

Type of Sign	Comment	Quantity	Unit	Lighted Y/N	Included in Roadway Lighting? yes/no	Cost/Sign	Extended Cost
1 O/H Span (50-100)	Signs at ends of tunnel	2	Ea.	Yes		114,319	\$228,637
2			Ea.				
3			Ea.				
4			Ea.				
5			Ea.				
6			Ea.				
7			Ea.				

MISCELLANEOUS 1 SIGN WORK	Location/Description	Cost
1		
2		

Signs Construction Subtotal \$228,637

**LIGHTING**

Continuous Roadway		Comments		No. Lanes	Number of Miles	Cost
1	Urban Type of Lighting					\$0
1	Freeway Type of Lighting					\$0
Interchange		Interchange Type	Type of Lighting	Number of Interchanges		Cost
1						\$0
2						\$0
3						\$0
Miscellaneous		Location/Description				Cost
1						
2						

Lighting Construction Subtotal \$0

**CONSTRUCTION TOTAL \$228,637**

*District factor will be applied when the total cost is passed to the const-1 worksheet*

**PROJECT COMMENTS**

Prepared by: CMS

Date Prepared/Modified: 05/05/16

Version 6.00

# BRIDGE CONSTRUCTION AND PRELIMINARY ENGINEERING COSTS

BRIDGE  
CONSTRUCTION

BRIDGE  
P. E.

Bridge Job #

Federal Structure ID

Manual CEI Cost Override :

Bridge # 1 CEI Cost :  18%

Manual PE Cost Adjustment :

Bridge #1 CN + CEI Cost :

P.E. Bridge # 1

BRIDGE #1 CN Cost : (input from Bridge PCES worksheet)

Comments - Constr. Engr. Br. #1:

Comments - Misc. P.E. Bridge #1:

Bridge Job #

Federal Structure ID

Manual CEI Cost Override :

Bridge # 2 CEI Cost :  18.0%

Manual PE Cost Adjustment :

Bridge #2 CN + CEI Cost :

P.E. Bridge # 2

BRIDGE #2 CN Cost : (input from Bridge PCES worksheet)

Comments - Constr. Engr. Br. #2:



Comments - Misc. P.E. Bridge #2:

Bridge Job #

Federal Structure ID

BRIDGE CONSTRUCTION AND PE COSTS (continued)				
	<i>Bike / PED Construction Cost</i>	\$0	<i>Bridge Construction Base (PCES)</i>	\$0
	<i>Bike / PED CE</i>	\$0	<i>Bridge Removal</i>	\$0
	<i>Bike / PED PE</i>	\$0	<i>Bridge CE (PCES)</i>	\$0
<b>NOTE : Structure Complexity is based upon Height,</b>			<b>Bridge Estimate. (2016)</b>	<b>\$0</b>
<b>Difficulty of Construction, and other Factors</b>			<b>Total Bridge P. E. Costs (PCES)</b>	<b>\$0</b>

Version 6.00

 Project Cost Estimating System <b>COMMENTS</b> 		
<b>General / Miscellaneous Comments from CONST, RW, &amp; UTILITY Worksheets</b>	<b>Team Member and Section</b>	<b>Date Entered</b>
<b>1</b> Project terrain changed from rolling to level based on comments from L&D on draft cost estimate	C. Sutkowski - HRCS Team	06/23/16
<b>2</b> Moved 10% of roadway and structures costs for general utility relocation from CONST-MISC sheet to MANUAL sheet	C. Sutkowski - HRCS Team	06/27/16
<b>3</b> Included costs for noise barriers in segment estimate as provided by noise team	C. Sutkowski - HRCS Team	06/29/16
<b>4</b> Updated costs for right-of-way with contingency added in line item in MANUAL sheet	C. Sutkowski - HRCS Team	06/29/16
<b>5</b>		
<b>6</b>		
<b>7</b>		
<b>8</b>		
<b>9</b>		
<b>10</b>		
<b>11</b>		
<b>12</b>		
<b>13</b>		
<b>14</b>		
<b>15</b>		

**VDOT Project Cost Estimating System  
MANUAL ESTIMATE**

	DATE	PE	RW	CN
<b>EXPENDITURES</b>	01/20/16	\$839,552		\$0
<b>RUMS</b>	01/28/16			\$0
<b>TRNS*PORT</b>				\$0
<b>AWARD</b>	01/28/16			\$0
<b>PROJECTION</b>	01/28/16			\$0

**ESTIMATE YEAR**

**AD YEAR**

FY2016		FY2016
\$0	PE	\$0
\$6,227,551	RW	\$6,227,551
\$0	CN	\$0
\$6,227,551	<b>TOTAL</b>	\$6,227,551

Job #	Phase	Comment	Estimate
	RW	Cost for utility work under RW project. See file Utilities Cost Estimate All Segments(AWP).xls	\$618,179
	RW	Cost for utility work under RW project. See file Utilities Cost Estimate All Segments(AWP).xls	\$0
	RW	Cost for Right-of-Way. See file HRCS ROW Costs.xlsx	\$5,609,372
	RW	Cost for Right-of-Way for Stormwater Management. See file HRCS ROW Costs.xlsx	\$0

Job #	Phase	Comment	Estimate
-------	-------	---------	----------



## Project Cost Estimating System SUMMARY PAGE

<b>DISTRICT</b>	<b>HAMPTON ROADS</b>		
<b>PROJECT NUMBER</b>	<b>64965081</b>		
<b>CONSTRUCTION END YEAR</b>	<b>FY2016</b>	<b>UPC</b>	<b>106724</b>
<b>AD YEAR</b>	<b>FY2016</b>	<small>RATE OF INFLATION TO AD</small>	<b>N/A</b>
<b>ESTIMATE YEAR</b>	<b>FY2016</b>	<small>INFLATION RATE DURING CN</small>	<b>N/A</b>
<small>Date of previous estimate</small>	01/28/16		
<b>PROJECT MANAGER / DESIGNER</b>	<b>Scott.Smizik</b>		
<b>Preliminary Engineering Estimate:</b>	<b>PCES</b>		
<b>Construction Estimate:</b>	<b>PCES</b>		
<b>Right-of-Way Estimate:</b>	<b>MANUAL</b>		
<b>Utilities Estimate:</b>	<b>MANUAL</b>		
<b>DATE</b>	<b>6/30/2016</b>		

THE FOLLOWING DATA WILL BE PROVIDED UPON COMPLETION OF THE REMAINDER OF THE WORKBOOK, WHICH IS ACCESSED BY SELECTING THE CONST, RW, & UTIL TABS BELOW

<b>CONSTRUCTION ESTIMATE</b>	<b>\$312,560,648</b>
<b>PRELIMINARY ENGINEERING ESTIMATE</b>	<b>\$11,924,751</b>
<b>RIGHT-OF-WAY &amp; UTILITIES ESTIMATE</b>	<b>\$31,514,132</b>
<b>TOTAL PROJECT ESTIMATE</b>	<b>\$355,999,531</b>

© Virginia Department of Transportation 2005

Revised 01/21/16

Estimate Class: Blank

Version 6.00



Project Cost Estimating System  
CONSTRUCTION / BRIDGE / PE

Project No. **64965081**

Interstate Project ?

Route Number   **Interstate Highway**

	CONST-1	CONST-2	Bridges (0)	Total
Geometric Standard	GS-5			
Construction Base	\$37,804,976	\$0	\$243,191,000	\$280,995,976
Bridge Removal			\$0	\$0
CE	\$4,725,622		\$26,839,050	\$31,564,672
Construction Estimate (2016)	\$42,530,598		\$270,030,050	\$312,560,648
To AdYear Inflation				\$0
Mid-point construction Inflation				\$0
Total Construction Estimate			\$270,030,050	<b>\$312,560,648</b>
Preliminary Engineering Cost	\$3,912,815		\$8,011,936	\$11,924,751

### CONSTRUCTION & PE TOTALS

**Total Construction Estimate** **\$312,560,648** **PCES**  
 (Roadway plus Bridge)

**Total Preliminary Engineering Estimate** **\$11,924,751** **PCES**  
 (Roadway plus Bridge)

Project Cost Estimating System

CONSTRUCTION / BRIDGE / PE

Project No. **64965081**

Interstate Project ?	<input type="text" value="Yes"/>	*	
Maintenance Project ?	<input type="text" value="No"/>	*	
Route Number	<input type="text" value="664"/>	*	Interstate Highway
Select INTERSTATE >	<input type="text" value="GS-5"/>	*	Principal Arterial - Freeway
Ad Date	<input type="text" value="2016"/>		Design Year = 2038
Design Year ADT	<input type="text" value="64,400"/>	*	Project Terrain <input type="text" value="Level"/>
<i>Box Must Be Empty</i>	<input type="text"/>		Approx. DHV = 9,660
Enter Design Speed (MPH) (Enter 60 or 70)	<input type="text" value="70"/>	*	Minimum Design Speed = 70 MPH
<i>Box Must Be Empty</i>	<input type="text"/>		
<i>Box Must Be Empty</i>	<input type="text"/>		
Project Length (mi.)	<input type="text" value="0.68"/>	*	
<b>Total Length - Adding or Building Two Lanes (mi.)</b>	<input type="text"/>	*	<b>Number of Additional Lanes:</b> <input type="text"/>
<b>Total Length - Adding or Building Four Lanes (mi.)</b>	<input type="text" value="0.28"/>	*	<b>Length of Add'l. Lanes (mi.):</b> <input type="text"/>
<b>Total Length - Building Ramps and Loops (mi.)</b>	<input type="text" value="0.55"/>	*	<input type="text" value="None"/>
Shoulder or Curb & Gutter ? (Select S or C&G)	<input type="text" value="S"/>	*	Enter Lane Width (ft) > <input type="text"/>
Median Type - Graded, Raised, or None ?	<input type="text" value="N"/>	*	Normal Lane Width(ft) <input type="text" value="12"/>
Number of Crossovers (Divided Highways ONLY)	<input type="text"/>	*	
Length - Curb & Gutter - Left PLUS Right Side (ft.)	<input type="text"/>		
Length - Sidewalk - Left PLUS Right Side (ft.)	<input type="text"/>		
<b>Bike / Pedestrian Type</b>	<input type="text" value="None"/>		
Total Length - Raised Median (ft.)	<input type="text"/>		
Number of Right Turn Lanes - Left PLUS Right Side	<input type="text"/>	*	
Number of Left Turn Lanes - (Undivided Only)	<input type="text"/>	*	

**HAMPTON ROADS**  
 110% Cost Factor used

<b>Construction Costs</b>	
Base #1 (PCES)	<input type="text" value="\$37,804,976"/>
Base #2	<input type="text" value="\$0"/>
Enter Const CE Cost >	<input type="text" value="\$0"/>
CE (12.5%)	<input type="text" value="\$4,725,622"/>
<b>Estimate (2016)</b>	<b><input type="text" value="\$42,530,598"/></b>

Signals, ITS, Signs and Lighting Costs*	<input type="text" value="\$888,187"/>
Cost of Large Drainage Structures	<input type="text" value="\$0"/>
In-Plan Utility Costs*	<input type="text" value="\$0"/>
<b>Adjustment for Unusual Construction Costs</b>	<b><input type="text" value="\$29,211,089"/></b>

*\* Totals include district factor calculations*

Additional (or Unusual) P. E. Costs	<input type="text"/>	
Select % of PE to be performed by Consultants	<input type="text" value="30%"/>	PE Cost (PCES) <b><input type="text" value="\$3,912,815"/></b>

**Note: Do Not Include Bridge P. E. Costs Here**

Roadway P. E. / Roadway Const. = 9.2%

© Virginia Department of Transportation 2005  
Revised 01/21/16

**Today's Date: 06/30/16**

**Version 6.00**

<b>Project Cost Estimating System</b> Miscellaneous Cost Estimates		
<b>COST OF LARGE DRAINAGE STRUCTURES</b>		
Job#	Description	Cost ( )
<input type="text"/>	<input type="text"/>	<input type="text"/>
<input type="text"/>	<input type="text"/>	<input type="text"/>
<input type="text"/>	<input type="text"/>	<input type="text"/>
<input type="text"/>	<input type="text"/>	<input type="text"/>
<input type="text"/>	<input type="text"/>	<input type="text"/>
		<b>\$0</b>
<b>ADJUSTMENT FOR UNUSUAL CONSTRUCTION COSTS</b>		
Type	Description	Cost ( )
Maintenance of Traffic	20% of roadway costs for MOT	\$2,232,931
Other	5% of roadway and structures costs for landscaping	\$12,717,783
Other	Resurfacing existing roadways	\$1,429,713
Other	Excessive excavation	\$0
Other	Excessive borrow	\$0
Other	Concrete barrier	\$323,513
Other	Guardrail and end treatments	\$730,419
Other	Removal of existing guardrail	\$308
Other	Demolition of existing pavement	\$0
Other	Noise barriers	\$0
Other	Retaining walls	\$0
Other	Tunnel costs	\$0
Other	Major in-plan utility work (water and sanitary sewer)	\$0
Other	Wet ponds and bioretention facilities	\$475,000
Environmental	Wetland and stream impacts	\$0
Environmental	Historic and archaeological resources	\$500,000
		<input type="text"/>
		<input type="text"/>
Other	40% contingency added to base construction cost	\$10,801,422
		<b>\$29,211,089</b>

Version 6.00

**SIGNALS, ITS, SIGNS and LIGHTING COST WORKSHEET**

Stand Alone Traffic Project:  No

UPC: 106724

**SIGNALS**

Permanent Signals	New/Mod.	Intersection Type	Major				Cross				Poles	Detection	Pre-emption	Cost
			Direction	Lanes	Direction	Lanes	Direction	Lanes	Direction	Lanes				
Location/Description														
1														\$0
2														\$0
3														\$0
4														\$0
5														\$0
6														\$0
7														\$0
8														\$0
9														\$0
10														\$0

Temporary Signals - New Equipment	Quantity	Cost
Temporary Signals - Modified Equipment		\$0

MISCELLANEOUS SIGNAL WORK	Location/Description	Cost
1		
2		
<b>Signals Construction Subtotal</b>		<b>\$0</b>

ITS	Location/Description	Cost
ITS WORK		
1		
2		
<b>ITS Construction Subtotal</b>		<b>\$0</b>

MAJOR SIGN STRUCTURES	Type of Sign	Comment	Quantity	Unit	Lighted Y/N	Included in Roadway Lighting? yes/no	Cost/Sign	Extended Cost
1	O/H Span (50-100)		2	Ea.	Yes		114,319	\$228,637
2	O/H Span (101-200)		1	Ea.	Yes		203,066	\$203,066
3				Ea.				
4				Ea.				
5				Ea.				
6				Ea.				
7				Ea.				
Location/Description								
MISCELLANEOUS SIGN WORK	Add mile post markers at \$1,000/mile for 0.68 miles							Cost
1								\$680
2								
<b>Signs Construction Subtotal</b>							<b>\$432,384</b>	

LIGHTING	Continuous Roadway	Urban Type of Lighting	Comments	No. Lanes	Number of Miles	Cost
	1					\$0
	1	Freeway Type of Lighting	Comments	No. Lanes	Number of Miles	Cost
	1	Conventional		6	0.68	\$375,059
	Interchange	Interchange Type	Type of Lighting		Number of Interchanges	Cost
	1					\$0
	2					\$0
	3					\$0
	Miscellaneous	Location/Description				Cost
	1					
	2					
<b>Lighting Construction Subtotal</b>					<b>\$375,059</b>	
<b>CONSTRUCTION TOTAL</b>					<b>\$807,443</b>	

*District factor will be applied when the total cost is passed to the const-1 worksheet*

PROJECT COMMENTS

Prepared by: CMS

Date Prepared/Modified: 05/05/16

Version 6.00

# BRIDGE CONSTRUCTION AND PRELIMINARY ENGINEERING COSTS

BRIDGE  
CONSTRUCTION

BRIDGE  
P. E.

Bridge Job #

Federal Structure ID

Manual CEI Cost Override :

Bridge # 1 CEI Cost :

11%

Manual PE Cost Adjustment :

Bridge #1 CN + CEI Cost :

P.E. Bridge # 1

BRIDGE #1 CN Cost : (input from Bridge PCES worksheet)

Comments - Constr. Engr. Br. #1:

Comments - Misc. P.E. Bridge #1:

Bridge Job #

Federal Structure ID

Manual CEI Cost Override :

Bridge # 2 CEI Cost :

16.0%

Manual PE Cost Adjustment :

Bridge #2 CN + CEI Cost :

P.E. Bridge # 2

BRIDGE #2 CN Cost : (input from Bridge PCES worksheet)

Comments - Constr. Engr. Br. #2:

Comments - Misc. P.E. Bridge #2:

Bridge Job #

Federal Structure ID

Manual CEI Cost Override :

Bridge # 3 CEI Cost :   
17.0%

Manual PE Cost Adjustment :

BRIDGE #3 CN Cost : (input from Bridge PCES worksheet)

Bridge #3 CN + CEI Cost :



P.E. Bridge # 3

Comments - Constr. Engr. Br. #3:

Comments - Misc. P.E. Bridge #3:

BRIDGE CONSTRUCTION AND PE COSTS (continued)			
		<i>Bridge Construction Base (PCES)</i>	\$243,191,000
<i>Bike / PED Construction Cost</i>	\$0		
<i>Bike / PED CE</i>	\$0	<i>Bridge Removal</i>	\$0
<i>Bike / PED PE</i>	\$0	<i>Bridge CE (PCES)</i>	\$26,839,050
<b>NOTE : Structure Complexity is based upon Height,</b>		<b>Bridge Estimate. (2016)</b>	<b>\$270,030,050</b>
<b>Difficulty of Construction, and other Factors</b>		<b>Total Bridge P. E. Costs (PCES)</b>	<b>\$8,011,936</b>
			<b>Version 6.00</b>



 Project Cost Estimating System COMMENTS 		
General / Miscellaneous Comments from CONST, RW, & UTILITY Worksheets	Team Member and Section	Date Entered
1 Project terrain changed from rolling to level based on comments from L&D on draft cost estimate	C. Sutkowski - HRCS Team	06/23/16
2 Moved 10% of roadway and structures costs for general utility relocation from CONST-MISC sheet to MANUAL sheet	C. Sutkowski - HRCS Team	06/27/16
3 Input revised bridge costs based on comments from S&B on draft cost estimate	C. Sutkowski - HRCS Team	06/28/16
4 Included costs for noise barriers in segment estimate as provided by noise team	C. Sutkowski - HRCS Team	06/29/16
5 Updated costs for right-of-way with contingency added in line item in MANUAL sheet	C. Sutkowski - HRCS Team	06/29/16
6 Added costs for right-of-way for stormwater management in MANUAL sheet	C. Sutkowski - HRCS Team	06/29/16
7		
8		
9		
10		
11		
12		
13		
14		
15		

**VDOT Project Cost Estimating System  
MANUAL ESTIMATE**

	DATE	PE	RW	CN
<b>EXPENDITURES</b>	01/20/16	\$839,552		\$0
<b>RUMS</b>	01/28/16			\$0
<b>TRNS*PORT</b>				\$0
<b>AWARD</b>	01/28/16			\$0
<b>PROJECTION</b>	01/28/16			\$0

**ESTIMATE YEAR**

**AD YEAR**

FY2016		FY2016
\$0	<b>PE</b>	\$0
\$31,514,132	<b>RW</b>	\$31,514,132
\$0	<b>CN</b>	\$0
\$31,514,132	<b>TOTAL</b>	\$31,514,132

Job #	Phase	Comment	Estimate
	RW	10% of roadway and structures costs for general utility relocation	\$25,435,565
	RW	Cost for utility work under RW project. See file Utilities Cost Estimate All Segments(AWP).xls	\$0
	RW	Cost for Right-of-Way. See file HRCS ROW Costs.xlsx	\$6,020,382
	RW	Cost for Right-of-Way for Stormwater Management. See file HRCS ROW Costs.xlsx	\$58,185

Job #	Phase	Comment	Estimate
-------	-------	---------	----------



## Project Cost Estimating System SUMMARY PAGE

DISTRICT	<b>HAMPTON ROADS</b>		
PROJECT NUMBER	<b>64965081</b>		
CONSTRUCTION END YEAR	<b>FY2016</b>	UPC	<b>106724</b>
AD YEAR	<b>FY2016</b>	RATE OF INFLATION TO AD	<b>N/A</b>
ESTIMATE YEAR	<b>FY2016</b>	INFLATION RATE DURING CN	<b>N/A</b>
Date of previous estimate	01/28/16		
PROJECT MANAGER / DESIGNER	<b>Scott.Smizik</b>		
Preliminary Engineering Estimate:	<b>PCES</b>		
Construction Estimate:	<b>PCES</b>		
Right-of-Way Estimate:	<b>MANUAL</b>		
Utilities Estimate:	<b>MANUAL</b>		
DATE	<b>6/30/2016</b>		

THE FOLLOWING DATA WILL BE PROVIDED UPON COMPLETION OF THE REMAINDER OF THE WORKBOOK, WHICH IS ACCESSED BY SELECTING THE CONST, RW, & UTIL TABS BELOW

CONSTRUCTION ESTIMATE	<b>\$249,424,681</b>
PRELIMINARY ENGINEERING ESTIMATE	<b>\$9,258,682</b>
RIGHT-OF-WAY & UTILITIES ESTIMATE	<b>\$25,872,323</b>
TOTAL PROJECT ESTIMATE	<b>\$284,555,686</b>

© Virginia Department of Transportation 2005

Revised 01/21/16

Estimate Class: Blank

Version 6.00

Project Cost Estimating System  
CONSTRUCTION / BRIDGE / PE

Project No. **64965081**

Interstate Project ?

Route Number   **Interstate Highway**

	CONST-1	CONST-2	Bridges (0)	Total
Geometric Standard	GS-5			
Construction Base	\$25,668,304	\$0	\$198,639,000	\$224,307,304
Bridge Removal			\$0	\$0
CE	\$3,208,538		\$21,908,840	\$25,117,378
Construction Estimate (2016)	\$28,876,841		\$220,547,840	\$249,424,681
To AdYear Inflation				\$0
Mid-point construction Inflation				\$0
Total Construction Estimate			\$220,547,840	<b>\$249,424,681</b>
Preliminary Engineering Cost	\$2,656,669		\$6,602,012	\$9,258,682

### CONSTRUCTION & PE TOTALS

**Total Construction Estimate** **\$249,424,681** **PCES**  
 (Roadway plus Bridge)

**Total Preliminary Engineering Estimate** **\$9,258,682** **PCES**  
 (Roadway plus Bridge)

Project Cost Estimating System

CONSTRUCTION / BRIDGE / PE

Project No. **64965081**

Interstate Project ?	<input type="text" value="Yes"/>	*					
Maintenance Project ?	<input type="text" value="No"/>	*					
Route Number	<input type="text" value="664"/>	*	Interstate Highway				
Select INTERSTATE >	<input type="text" value="GS-5"/>	*	Principal Arterial - Freeway				
Ad Date	<input type="text" value="2016"/>		Design Year = 2038				
Design Year ADT	<input type="text" value="57,800"/>	*	Project Terrain <input type="text" value="Level"/>				
<i>Box Must Be Empty</i>	<input type="text"/>		Approx. DHV = 8,670				
Enter Design Speed (MPH) (Enter 60 or 70)	<input type="text" value="70"/>	*	Design Speed = 70 MPH				
<i>Box Must Be Empty</i>	<input type="text"/>						
<i>Box Must Be Empty</i>	<input type="text"/>						
Project Length (mi.)	<input type="text" value="0.68"/>	*					
Total Length - Adding or Building <u>Two Lanes</u> (mi.)	<input type="text"/>	*	<table border="0" style="width: 100%; font-size: small;"> <tr> <td style="text-align: center;"><i>Number of Additional Lanes:</i></td> <td style="text-align: center;"><i>Length of Add'l. Lanes (mi.):</i></td> </tr> <tr> <td><input type="text"/></td> <td><input type="text"/></td> </tr> </table>	<i>Number of Additional Lanes:</i>	<i>Length of Add'l. Lanes (mi.):</i>	<input type="text"/>	<input type="text"/>
<i>Number of Additional Lanes:</i>	<i>Length of Add'l. Lanes (mi.):</i>						
<input type="text"/>	<input type="text"/>						
Total Length - Adding or Building <u>Four Lanes</u> (mi.)	<input type="text" value="0.28"/>	*	<input type="text" value="None"/>				
Total Length - Building <u>Ramps and Loops</u> (mi.)	<input type="text"/>	*	<input type="text" value="None"/>				
Shoulder or Curb & Gutter ? (Select S or C&G)	<input type="text" value="S"/>	*	Enter Lane Width (ft) > <input type="text"/>				
Median Type - Graded, Raised, or None ?	<input type="text" value="N"/>	*	Normal Lane Width(ft) <input type="text" value="12"/>				
Number of Crossovers (Divided Highways ONLY)	<input type="text"/>	*					
Length - Curb & Gutter - Left PLUS Right Side (ft.)	<input type="text"/>						
Length - Sidewalk - Left PLUS Right Side (ft.)	<input type="text"/>						
Bike / Pedestrian Type	<input type="text" value="None"/>						
Total Length - Raised Median (ft.)	<input type="text"/>						
Number of <u>Right Turn Lanes</u> - Left PLUS Right Side	<input type="text"/>	*					
Number of Left Turn Lanes - (Undivided Only)	<input type="text"/>	*					

**HAMPTON ROADS**  
 110% Cost Factor used  
**Construction Costs**

Signals, ITS, Signs and Lighting Costs*	<input type="text" value="\$850,681"/>		Base #1 (PCES)	<input type="text" value="\$25,668,304"/>
Cost of Large Drainage Structures	<input type="text" value="\$0"/>		Base #2	<input type="text" value="\$0"/>
In-Plan Utility Costs*	<input type="text" value="\$0"/>		Enter Const CE Cost >	<input type="text" value="\$0"/>
Adjustment for Unusual Construction Costs	<input type="text" value="\$21,698,206"/>		CE (12.5%)	<input type="text" value="\$3,208,538"/>
			Estimate (2016)	<input type="text" value="\$28,876,841"/>

*\* Totals include district factor calculations*

Additional (or Unusual) P. E. Costs	<input type="text"/>	
Select % of PE to be performed by Consultants	<input type="text" value="30%"/>	PE Cost (PCES) <input type="text" value="\$2,656,669"/>



**Note: Do Not Include Bridge P. E. Costs Here**

Roadway P. E. / Roadway Const. = 9.2%

© Virginia Department of Transportation 2005  
Revised 01/21/16

**Today's Date: 06/30/16**

**Version 6.00**

	<b>Project Cost Estimating System</b> <b>Miscellaneous Cost Estimates</b>	
---	--	---

**COST OF LARGE DRAINAGE STRUCTURES**

Job#	Description	Cost ()
		<b>\$0</b>

**ADJUSTMENT FOR UNUSUAL CONSTRUCTION COSTS**

Type	Description	Cost ()
Maintenance of Traffic	20% of roadway costs for MOT	\$1,208,299
Other	5% of roadway and structures costs for landscaping	\$10,234,025
Other	Resurfacing existing roadways	\$1,363,902
Other	Excessive excavation	\$0
Other	Excessive borrow	\$0
Other	Concrete barrier	\$189,439
Other	Guardrail and end treatments	\$268,431
Other	Removal of existing guardrail	\$308
Other	Demolition of existing pavement	\$0
Other	Noise barriers	\$0
Other	Retaining walls	\$0
Other	Tunnel costs	\$0
Other	Major in-plan utility work (water and sanitary sewer)	\$0
Other	Wet ponds and bioretention facilities	\$600,000
Environmental	Wetland and stream impacts	\$0
Environmental	Historic and archaeological resources	\$500,000
Other	40% contingency added to base construction cost	\$7,333,801
		<b>\$21,698,206</b>

Version 6.00

**SIGNALS, ITS, SIGNS and LIGHTING COST WORKSHEET**

Stand Alone Traffic Project:  No

UPC: 106724

SIGNALS		New/Mod.	Intersection Type	Major				Cross				Poles	Detection	Pre-emption	Cost
Permanent Signals				Direction	Lanes	Direction	Lanes	Direction	Lanes	Direction	Lanes				
Location/Description															
1															\$0
2															\$0
3															\$0
4															\$0
5															\$0
6															\$0
7															\$0
8															\$0
9															\$0
10															\$0

Temporary Signals - New Equipment	Quantity	Cost
Temporary Signals - Modified Equipment		\$0

MISCELLANEOUS SIGNAL WORK	Location/Description	Cost
1		
2		

Signals Construction Subtotal \$0

ITS	Location/Description	Cost
ITS WORK	1	
	2	

ITS Construction Subtotal \$0

MAJOR SIGN STRUCTURES		Quantity	Unit	Lighted Y/N	Included in Roadway Lighting? yes/no	Cost/Sign	Extended Cost
1	O/H Span (50-100)	2	Ea.	Yes		114,319	\$228,637
2	O/H Span (101-200)	1	Ea.	Yes		203,066	\$203,066
3			Ea.				
4			Ea.				
5			Ea.				
6			Ea.				
7			Ea.				

MISCELLANEOUS SIGN WORK	Location/Description	Cost
1	Add mile post markers at \$1,000/mile for 0.68 miles	\$680
2		

Signs Construction Subtotal \$432,384

LIGHTING		Continuous Roadway		Interchange		Miscellaneous	
		Urban Type of Lighting	Comments	No. Lanes	Number of Miles	Cost	
1						\$0	
		Freeway Type of Lighting	Comments	No. Lanes	Number of Miles	Cost	
1		Conventional		4	0.68	\$340,963	
		Interchange Type	Type of Lighting		Number of Interchanges	Cost	
1						\$0	
2						\$0	
3						\$0	
		Location/Description				Cost	
1							
2							

Lighting Construction Subtotal \$340,963

**CONSTRUCTION TOTAL \$773,347**

*District factor will be applied when the total cost is passed to the const-1 worksheet*

PROJECT COMMENTS

Prepared by: CMS

Date Prepared/Modified: 05/05/16

Version 6.00



# BRIDGE CONSTRUCTION AND PRELIMINARY ENGINEERING COSTS

BRIDGE  
CONSTRUCTION

BRIDGE  
P. E.

Bridge Job #

Federal Structure ID

Manual CEI Cost Override :

Bridge # 1 CEI Cost :

11%

Manual PE Cost Adjustment :

Bridge #1 CN + CEI Cost :

P.E. Bridge # 1

BRIDGE #1 CN Cost : (input from Bridge PCES worksheet)

Comments - Constr. Engr. Br. #1:

Comments - Misc. P.E. Bridge #1:

Bridge Job #

Federal Structure ID

Manual CEI Cost Override :

Bridge # 2 CEI Cost :

18.0%

Manual PE Cost Adjustment :

Bridge #2 CN + CEI Cost :

P.E. Bridge # 2

BRIDGE #2 CN Cost : (input from Bridge PCES worksheet)

Comments - Constr. Engr. Br. #2:

Comments - Misc. P.E. Bridge #2:

Bridge Job #

Federal Structure ID

Manual CEI Cost Override :

Bridge # 3 CEI Cost :   
17.0%

Manual PE Cost Adjustment :

BRIDGE #3 CN Cost : (input from Bridge PCES worksheet)



Bridge #3 CN + CEI Cost :

P.E. Bridge # 3

Comments - Constr. Engr. Br. #3:

Comments - Misc. P.E. Bridge #3:

BRIDGE CONSTRUCTION AND PE COSTS (continued)			
		<i>Bridge Construction Base (PCES)</i>	\$198,639,000
<i>Bike / PED Construction Cost</i>	\$0		
<i>Bike / PED CE</i>	\$0	<i>Bridge Removal</i>	\$0
<i>Bike / PED PE</i>	\$0	<i>Bridge CE (PCES)</i>	\$21,908,840
<b>NOTE : Structure Complexity is based upon Height,</b>		<b>Bridge Estimate. (2016)</b>	<b>\$220,547,840</b>
<b>Difficulty of Construction, and other Factors</b>		<b>Total Bridge P. E. Costs (PCES)</b>	<b>\$6,602,012</b>
			<b>Version 6.00</b>

 Project Cost Estimating System <b>COMMENTS</b> 		
<b>General / Miscellaneous Comments from CONST, RW, &amp; UTILITY Worksheets</b>	<b>Team Member and Section</b>	<b>Date Entered</b>
<b>1</b> Project terrain changed from rolling to level based on comments from L&D on draft cost estimate	C. Sutkowski - HRCS Team	06/23/16
<b>2</b> Moved 10% of roadway and structures costs for general utility relocation from CONST-MISC sheet to MANUAL sheet	C. Sutkowski - HRCS Team	06/27/16
<b>3</b> Input revised bridge costs based on comments from S&B on draft cost estimate	C. Sutkowski - HRCS Team	06/28/16
<b>4</b> Included costs for noise barriers in segment estimate as provided by noise team	C. Sutkowski - HRCS Team	06/29/16
<b>5</b> Updated costs for right-of-way with contingency added in line item in MANUAL sheet	C. Sutkowski - HRCS Team	06/29/16
<b>6</b> Added costs for right-of-way for stormwater management in MANUAL sheet	C. Sutkowski - HRCS Team	06/29/16
<b>7</b>		
<b>8</b>		
<b>9</b>		
<b>10</b>		
<b>11</b>		
<b>12</b>		
<b>13</b>		
<b>14</b>		
<b>15</b>		

**VDOT Project Cost Estimating System  
MANUAL ESTIMATE**

	DATE	PE	RW	CN
<b>EXPENDITURES</b>	01/20/16	\$839,552		\$0
<b>RUMS</b>	01/28/16			\$0
<b>TRNS*PORT</b>				\$0
<b>AWARD</b>	01/28/16			\$0
<b>PROJECTION</b>	01/28/16			\$0

**ESTIMATE YEAR**

**AD YEAR**

FY2016		FY2016
\$0	PE	\$0
\$25,872,323	RW	\$25,872,323
\$0	CN	\$0
\$25,872,323	<b>TOTAL</b>	\$25,872,323

Job #	Phase	Comment	Estimate
	RW	10% of roadway and structures costs for general utility relocation	\$20,468,050
	RW	Cost for utility work under RW project. See file Utilities Cost Estimate All Segments(AWP).xls	\$0
	RW	Cost for Right-of-Way. See file HRCS ROW Costs.xlsx	\$5,356,120
	RW	Cost for Right-of-Way for Stormwater Management. See file HRCS ROW Costs.xlsx	\$48,153

Job #	Phase	Comment	Estimate
-------	-------	---------	----------



# Project Cost Estimating System

## SUMMARY PAGE

DISTRICT	<b>HAMPTON ROADS</b>		
PROJECT NUMBER	<b>64965081</b>		
CONSTRUCTION END YEAR	<b>FY2016</b>	UPC	<b>106724</b>
AD YEAR	<b>FY2016</b>	RATE OF INFLATION TO AD	<b>N/A</b>
ESTIMATE YEAR	<b>FY2016</b>	INFLATION RATE DURING CN	<b>N/A</b>
Date of previous estimate	01/28/16		
PROJECT MANAGER / DESIGNER	<b>Scott.Smizik</b>		
Preliminary Engineering Estimate:	<b>PCES</b>		
Construction Estimate:	<b>PCES</b>		
Right-of-Way Estimate:	<b>MANUAL</b>		
Utilities Estimate:	<b>MANUAL</b>		
DATE	<b>7/12/2016</b>		

THE FOLLOWING DATA WILL BE PROVIDED UPON COMPLETION OF THE REMAINDER OF THE WORKBOOK, WHICH IS ACCESSED BY SELECTING THE CONST, RW, & UTIL TABS BELOW



CONSTRUCTION ESTIMATE	<b>\$429,926,467</b>
PRELIMINARY ENGINEERING ESTIMATE	<b>\$31,742,267</b>
RIGHT-OF-WAY & UTILITIES ESTIMATE	<b>\$49,449,811</b>
TOTAL PROJECT ESTIMATE	<b>\$511,118,545</b>

© Virginia Department of Transportation 2005

Revised 01/21/16

Estimate Class: Blank

Version 6.00

	Project Cost Estimating System CONSTRUCTION / BRIDGE / PE	
---	--	---

Project No. **64965081**

Interstate Project ?

Route Number   **Interstate Highway**

	CONST-1	CONST-2	Bridges (0)	Total
Geometric Standard	GS-5			
Construction Base	\$242,849,544	\$0	\$140,727,000	\$383,576,544
Bridge Removal			\$0	\$0
CE	\$30,356,193		\$15,993,730	\$46,349,923
Construction Estimate (2016)	\$273,205,737		\$156,720,730	\$429,926,467
To AdYear Inflation				\$0
Mid-point construction Inflation				\$0
Total Construction Estimate			\$156,720,730	<b>\$429,926,467</b>
Preliminary Engineering Cost	\$25,134,928		\$6,607,339	\$31,742,267

### CONSTRUCTION & PE TOTALS

Total Construction Estimate <i>(Roadway plus Bridge)</i>	<b>\$429,926,467</b>	<b>PCES</b>
Total Preliminary Engineering Estimate <i>(Roadway plus Bridge)</i>	<b>\$31,742,267</b>	<b>PCES</b>

Project Cost Estimating System

CONSTRUCTION / BRIDGE / PE

Project No. **64965081**

Interstate Project ?	<input type="text" value="Yes"/>	*									
Maintenance Project ?	<input type="text" value="No"/>	*									
Route Number	<input type="text" value="664"/>	*	Interstate Highway								
Select INTERSTATE >	<input type="text" value="GS-5"/>	*	Principal Arterial - Freeway								
Ad Date	<input type="text" value="2016"/>		Design Year = 2038								
Design Year ADT	<input type="text" value="62,900"/>	*	Project Terrain <input type="text" value="Level"/>								
<i>Box Must Be Empty</i>	<input type="text"/>		Approx. DHV = 9,435								
Enter Design Speed (MPH) (Enter 60 or 70)	<input type="text" value="70"/>	*	Minimum Design Speed = 70 MPH								
<i>Box Must Be Empty</i>	<input type="text"/>										
<i>Box Must Be Empty</i>	<input type="text"/>										
Project Length (mi.)	<input type="text" value="5.10"/>	*									
Total Length - Adding or Building <u>Two Lanes</u> (mi.)	<input type="text" value="2.16"/>	*	<table border="0" style="width: 100%;"> <tr> <td style="text-align: center;"><i>Number of Additional Lanes:</i></td> <td style="text-align: center;"><i>Length of Add'l. Lanes (mi.):</i></td> </tr> <tr> <td style="text-align: center;"><input type="text" value="+ One Add'l. Lane"/></td> <td style="text-align: center;"><input type="text" value="0.67"/></td> </tr> <tr> <td style="text-align: center;"><input type="text" value="+ Two Add'l. Lanes"/></td> <td style="text-align: center;"><input type="text" value="0.30"/></td> </tr> <tr> <td style="text-align: center;"><input type="text" value="None"/></td> <td style="text-align: center;"><input type="text"/></td> </tr> </table>	<i>Number of Additional Lanes:</i>	<i>Length of Add'l. Lanes (mi.):</i>	<input type="text" value="+ One Add'l. Lane"/>	<input type="text" value="0.67"/>	<input type="text" value="+ Two Add'l. Lanes"/>	<input type="text" value="0.30"/>	<input type="text" value="None"/>	<input type="text"/>
<i>Number of Additional Lanes:</i>	<i>Length of Add'l. Lanes (mi.):</i>										
<input type="text" value="+ One Add'l. Lane"/>	<input type="text" value="0.67"/>										
<input type="text" value="+ Two Add'l. Lanes"/>	<input type="text" value="0.30"/>										
<input type="text" value="None"/>	<input type="text"/>										
Total Length - Adding or Building <u>Four Lanes</u> (mi.)	<input type="text" value="3.11"/>	*									
Total Length - Building <u>Ramps and Loops</u> (mi.)	<input type="text" value="0.71"/>	*									
Shoulder or Curb & Gutter ? (Select S or C&G)	<input type="text" value="S"/>	*	Enter Lane Width (ft) > <input type="text"/>								
Median Type - Graded, Raised, or None ?	<input type="text" value="N"/>	*	Normal Lane Width(ft) <input type="text" value="12"/>								
Number of Crossovers (Divided Highways ONLY)	<input type="text"/>	*									
Length - Curb & Gutter - Left PLUS Right Side (ft.)	<input type="text"/>										
Length - Sidewalk - Left PLUS Right Side (ft.)	<input type="text"/>										
Bike / Pedestrian Type	<input type="text" value="None"/>										
Total Length - Raised Median (ft.)	<input type="text"/>										
Number of <u>Right Turn Lanes</u> - Left PLUS Right Side	<input type="text"/>	*									
Number of Left Turn Lanes - (Undivided Only)	<input type="text"/>	*									

**HAMPTON ROADS**  
 110% Cost Factor used  
**Construction Costs**

Signals, ITS, Signs and Lighting Costs*	<input type="text" value="\$7,578,486"/>		Base #1 (PCES)	<input type="text" value="\$242,849,544"/>
Cost of Large Drainage Structures	<input type="text" value="\$0"/>		Base #2	<input type="text" value="\$0"/>
In-Plan Utility Costs*	<input type="text" value="\$0"/>		Enter Const CE Cost >	<input type="text" value="\$0"/>
Adjustment for Unusual Construction Costs	<input type="text" value="\$186,780,467"/>		CE (12.5%)	<input type="text" value="\$30,356,193"/>
<i>* Totals include district factor calculations</i>			Estimate (2016)	<input type="text" value="\$273,205,737"/>

Additional (or Unusual) P. E. Costs	<input type="text"/>	
Select % of PE to be performed by Consultants	<input type="text" value="30%"/>	PE Cost (PCES) <input type="text" value="\$25,134,928"/>



**Note: Do Not Include Bridge P. E. Costs Here**

Roadway P. E. / Roadway Const. = 9.2%

© Virginia Department of Transportation 2005  
Revised 01/21/16

**Today's Date: 07/12/16**

**Version 6.00**

<b>Project Cost Estimating System</b> Miscellaneous Cost Estimates		
<b>COST OF LARGE DRAINAGE STRUCTURES</b>		
Job#	Description	Cost ()
<input type="text"/>	<input type="text"/>	<input type="text"/>
<input type="text"/>	<input type="text"/>	<input type="text"/>
<input type="text"/>	<input type="text"/>	<input type="text"/>
<input type="text"/>	<input type="text"/>	<input type="text"/>
<input type="text"/>	<input type="text"/>	<input type="text"/>
		<b>\$0</b>
<b>ADJUSTMENT FOR UNUSUAL CONSTRUCTION COSTS</b>		
Type	Description	Cost ()
Maintenance of Traffic	20% of roadway costs for MOT	\$25,415,860
Other	5% of roadway and structures costs for landscaping	\$13,390,315
Other	Resurfacing existing roadways	\$9,089,117
Other	Excessive excavation	\$0
Other	Excessive borrow	\$0
Other	Concrete barrier	\$7,375,759
Other	Guardrail and end treatments	\$2,777,792
Other	Removal of existing guardrail	\$57,030
Other	Demolition of existing pavement	\$650,598
Other	Noise barriers	\$22,733,633
Other	Retaining walls	\$30,916,336
Other	Tunnel costs	\$0
Other	Major in-plan utility work (water and sanitary sewer)	\$488,945
Other	Wet ponds and bioretention facilities	\$3,800,000
Environmental	Wetland and stream impacts	\$199,500
Environmental	Historic and archaeological resources	\$500,000
		<input type="text"/>
		<input type="text"/>
Other	40% contingency added to base construction cost	\$69,385,584
		<b>\$186,780,467</b>

Version 6.00

**SIGNALS, ITS, SIGNS and LIGHTING COST WORKSHEET**

Stand Alone Traffic Project:  No

UPC: 106724

**SIGNALS**

Permanent Signals	New/Mod.	Intersection Type	Major				Cross				Poles	Detection	Pre-emption	Cost
			Direction	Lanes	Direction	Lanes	Direction	Lanes	Direction	Lanes				
Location/Description														
1														\$0
2														\$0
3														\$0
4														\$0
5														\$0
6														\$0
7														\$0
8														\$0
9														\$0
10														\$0

Temporary Signals - New Equipment	Quantity	Cost
Temporary Signals - Modified Equipment		\$0

MISCELLANEOUS SIGNAL WORK	Location/Description	Cost
1		
2		

Signals Construction Subtotal \$0

**ITS**

ITS WORK	Location/Description	Cost
1		
2		

ITS Construction Subtotal \$0

**MAJOR SIGN STRUCTURES**

Type of Sign	Comment	Quantity	Unit	Lighted Y/N	Included in Roadway Lighting? yes/no	Cost/Sign	Extended Cost
1 O/H Span (50-100)		2	Ea.	Yes	<input type="checkbox"/>	114,319	\$228,637
2 O/H Span (50-100)		1	Ea.	No	<input type="checkbox"/>	112,819	\$112,819
3 O/H Span (101-200)		5	Ea.	No	<input type="checkbox"/>	200,566	\$1,002,832
4 O/H Span (101-200)		2	Ea.	Yes	<input type="checkbox"/>	203,066	\$406,133
5 Cantilever		2	Ea.	No	<input type="checkbox"/>	56,409	\$112,819
6 Cantilever		1	Ea.	Yes	<input type="checkbox"/>	57,909	\$57,909
7			Ea.				

MISCELLANEOUS SIGN WORK	Location/Description	Cost
1	Add mile post markers at \$1,000/mile for 5.10 miles	\$5,100
2		

Signs Construction Subtotal \$1,926,249

**LIGHTING**

Continuous Roadway		Comments		No. Lanes	Number of Miles	Cost
1	Urban Type of Lighting			<input type="checkbox"/>	<input type="checkbox"/>	\$0
1	Freeway Type of Lighting			8	5.10	\$4,443,174
Interchange		Type of Lighting		Number of Interchanges		Cost
1	Trumpet	Conventional		1		\$520,109
2						\$0
3						\$0
Miscellaneous		Location/Description				Cost
1						
2						

Lighting Construction Subtotal \$4,963,283

**CONSTRUCTION TOTAL \$6,889,532**

*District factor will be applied when the total cost is passed to the const-1 worksheet*

**PROJECT COMMENTS**

Prepared by: CMS

Date Prepared/Modified: 05/05/16

Version 6.00

# BRIDGE CONSTRUCTION AND PRELIMINARY ENGINEERING COSTS

BRIDGE  
CONSTRUCTION

BRIDGE  
P. E.

Bridge Job #

Federal Structure ID

Manual CEI Cost Override :

Bridge # 1 CEI Cost :

16%

Manual PE Cost Adjustment :

Bridge #1 CN + CEI Cost :

P.E. Bridge # 1

BRIDGE #1 CN Cost : (input from Bridge PCES worksheet)

Comments - Constr. Engr. Br. #1:

Comments - Misc. P.E. Bridge #1:

Bridge Job #

Federal Structure ID

Manual CEI Cost Override :

Bridge # 2 CEI Cost :

13.0%

Manual PE Cost Adjustment :

Bridge #2 CN + CEI Cost :

P.E. Bridge # 2

BRIDGE #2 CN Cost : (input from Bridge PCES worksheet)

Comments - Constr. Engr. Br. #2:

Comments - Misc. P.E. Bridge #2:

Bridge Job #

Federal Structure ID

Manual CEI Cost Override :

Bridge # 3 CEI Cost :   
13.0%

Manual PE Cost Adjustment :

BRIDGE #3 CN Cost : (input from Bridge PCES worksheet)

Bridge #3 CN + CEI Cost :

P.E. Bridge # 3

Comments - Constr. Engr. Br. #3:

Comments - Misc. P.E. Bridge #3:

BRIDGE CONSTRUCTION AND PE COSTS (continued)

BRIDGE CONSTRUCTION

BRIDGE P. E.

Bridge Job #

[Yellow box]

Federal Structure ID

20736

Manual CEI Cost Override :

[Yellow box]

Bridge # 4 CEI Cost : \$318,080

14.0%

Manual PE Cost Adjustment :

[Yellow box]

Bridge #4 CN + CEI Cost :

\$2,590,080

P.E. Bridge # 4

\$192,647

BRIDGE #4 CN Cost : (input from Bridge PCES worksheet) \$2,272,000

Comments - Constr. Engr. Br. #4:

[White box]

Comments - Misc. P.E. Bridge #4:

[White box]

Bridge Job #

[Yellow box]

Federal Structure ID

20738

Manual CEI Cost Override :

[Yellow box]

Bridge # 5 CEI Cost : \$290,080

14.0%

Manual PE Cost Adjustment :

[Yellow box]

Bridge #5 CN + CEI Cost :

\$2,362,080

P.E. Bridge # 5

\$186,357

BRIDGE #5 CN Cost : (input from Bridge PCES worksheet) \$2,072,000

Comments - Constr. Engr. Br. #5:

[White box]

Comments - Misc. P.E. Bridge #5:

[White box]

Bridge Job #

[Yellow box]

Federal Structure ID

20740

Manual CEI Cost Override :

Bridge # 6 CEI Cost :

11.0%

Manual PE Cost Adjustment :

BRIDGE #6 CN Cost : (input from Bridge PCES worksheet)

Bridge #6 CN + CEI Cost :

P.E. Bridge # 6

Comments - Constr. Engr. Br. #6:

Comments - Misc. P.E. Bridge #6:

BRIDGE CONSTRUCTION AND PE COSTS (continued)

BRIDGE CONSTRUCTION

BRIDGE P. E.

Bridge Job #

[Yellow box]

Federal Structure ID

20742

Manual CEI Cost Override :

[Yellow box]

Bridge # 7 CEI Cost : \$546,610

11.8%

Manual PE Cost Adjustment :

[Yellow box]

Bridge #7 CN + CEI Cost :

\$5,198,610

P.E. Bridge # 7

\$267,498

BRIDGE #7 CN Cost : (input from Bridge PCES worksheet) \$4,652,000

Comments - Constr. Engr. Br. #7:

[White box]

Comments - Misc. P.E. Bridge #7:

[White box]

Bridge Job #

[Yellow box]

Federal Structure ID

20744

Manual CEI Cost Override :

[Yellow box]

Bridge # 8 CEI Cost : \$91,970

17.0%

Manual PE Cost Adjustment :

[Yellow box]

Bridge #8 CN + CEI Cost :

\$632,970

P.E. Bridge # 8

\$138,207

BRIDGE #8 CN Cost : (input from Bridge PCES worksheet) \$541,000

Comments - Constr. Engr. Br. #8:

[White box]

Comments - Misc. P.E. Bridge #8:

[White box]

Bridge Job #

[Yellow box]

Federal Structure ID

26

Manual CEI Cost Override :



Bridge # 9 CEI Cost :

11.0%

Manual PE Cost Adjustment :

BRIDGE #9 CN Cost : (input from Bridge PCES worksheet)

Bridge #9 CN + CEI Cost :

P.E. Bridge # 9

Comments - Constr. Engr. Br. #9:

Comments - Misc. P.E. Bridge #9:

BRIDGE CONSTRUCTION AND PE COSTS (continued)

BRIDGE  
CONSTRUCTION

BRIDGE  
P. E.

Bridge Job #

Federal Structure ID

Manual CEI Cost Override :

Bridge # 10 CEI Cost :

11.0%

Manual PE Cost Adjustment :

Bridge #10 CN + CEI Cost :

P.E. Bridge # 10

BRIDGE #10 CN Cost : (input from Bridge PCES worksheet)



Comments - Constr. Engr. Br. #10:

Comments - Misc. P.E. Bridge #10:

Bridge Job #

Federal Structure ID

Manual CEI Cost Override :

Bridge # 11 CEI Cost :

11.0%

Manual PE Cost Adjustment :

Bridge #11 CN + CEI Cost :

P.E. Bridge # 11

BRIDGE #11 CN Cost : (input from Bridge PCES worksheet)



Comments - Constr. Engr. Br. #11:

Comments - Misc. P.E. Bridge #11:

Bridge Job #

Federal Structure ID

Manual CEI Cost Override :

Bridge # 12 CEI Cost : \$1,594,010  
11.0%

Manual PE Cost Adjustment :

BRIDGE #12 CN Cost : (input from Bridge PCES worksheet) \$14,491,000

Bridge #12 CN + CEI Cost : \$16,085,010

P.E. Bridge # 12 \$576,935

Comments - Constr. Engr. Br. #12:

Comments - Misc. P.E. Bridge #12:

BRIDGE CONSTRUCTION AND PE COSTS (continued)

**BRIDGE  
CONSTRUCTION**

**BRIDGE  
P. E.**

Bridge Job #

Federal Structure ID

Manual CEI Cost Override :

Bridge # 13 CEI Cost :

12.0%

Manual PE Cost Adjustment :

Bridge #13 CN + CEI Cost :

P.E. Bridge # 13

BRIDGE #13 CN Cost : (input from Bridge PCES worksheet)



Comments - Constr. Engr. Br. #13:

Comments - Misc. P.E. Bridge #13:

Bridge Job #

Federal Structure ID

Manual CEI Cost Override :

Bridge # 14 CEI Cost :

11.0%

Manual PE Cost Adjustment :

Bridge #14 CN + CEI Cost :

P.E. Bridge # 14

BRIDGE #14 CN Cost : (input from Bridge PCES worksheet)



Comments - Constr. Engr. Br. #14:

Comments - Misc. P.E. Bridge #14:

Bridge Job #

Federal Structure ID

Manual CEI Cost Override :

Bridge # 15 CEI Cost : \$3,093,400  
\$3,093,400  
*11.0%*

Manual PE Cost Adjustment : \$363,580

BRIDGE #15 CN Cost : (input from Bridge PCES worksheet) \$27,391,000

Bridge #15 CN + CEI Cost : \$30,484,400



P.E. Bridge # 15 \$1,346,220

Comments - Constr. Engr. Br. #15:

Comments - Misc. P.E. Bridge #15:

Total for bridge #15 is a total of four separate bridges due to lack of space to input individually. The CEI cost and PE cost were computed for each

BRIDGE CONSTRUCTION AND PE COSTS (continued)			
		<i>Bridge Construction Base (PCES)</i>	\$140,727,000
<i>Bike / PED Construction Cost</i>	\$0		
<i>Bike / PED CE</i>	\$0	<i>Bridge Removal</i>	\$0
<i>Bike / PED PE</i>	\$0	<i>Bridge CE (PCES)</i>	\$15,993,730
<b>NOTE : Structure Complexity is based upon Height,</b>		<b>Bridge Estimate. (2016)</b>	<b>\$156,720,730</b>
<b>Difficulty of Construction, and other Factors</b>		<b>Total Bridge P. E. Costs (PCES)</b>	<b>\$6,607,339</b>
			<b>Version 6.00</b>

 Project Cost Estimating System <b>COMMENTS</b> 		
<b>General / Miscellaneous Comments from CONST, RW, &amp; UTILITY Worksheets</b>	<b>Team Member and Section</b>	<b>Date Entered</b>
<b>1</b> Project terrain changed from rolling to level based on comments from L&D on draft cost estimate	C. Sutkowski - HRCS Team	06/23/16
<b>2</b> Moved 10% of roadway and structures costs for general utility relocation from CONST-MISC sheet to MANUAL sheet	C. Sutkowski - HRCS Team	06/27/16
<b>3</b> Input revised bridge costs based on comments from S&B on draft cost estimate	C. Sutkowski - HRCS Team	06/28/16
<b>4</b> Included costs for noise barriers in segment estimate as provided by noise team	C. Sutkowski - HRCS Team	06/29/16
<b>5</b> Updated costs for right-of-way with contingency added in line item in MANUAL sheet	C. Sutkowski - HRCS Team	06/29/16
<b>6</b> Added costs for right-of-way for stormwater management in MANUAL sheet	C. Sutkowski - HRCS Team	06/29/16
<b>7</b>		
<b>8</b>		
<b>9</b>		
<b>10</b>		
<b>11</b>		
<b>12</b>		
<b>13</b>		
<b>14</b>		
<b>15</b>		

**VDOT Project Cost Estimating System  
MANUAL ESTIMATE**

	DATE	PE	RW	CN
<b>EXPENDITURES</b>	01/20/16	\$839,552		\$0
<b>RUMS</b>	01/28/16			\$0
<b>TRNS*PORT</b>				\$0
<b>AWARD</b>	01/28/16			\$0
<b>PROJECTION</b>	01/28/16			\$0

**ESTIMATE YEAR**

**AD YEAR**

FY2016		FY2016
\$0	PE	\$0
\$49,449,811	RW	\$49,449,811
\$0	CN	\$0
\$49,449,811	<b>TOTAL</b>	\$49,449,811

Job #	Phase	Comment	Estimate
	RW	10% of roadway and structures costs for general utility relocation	\$26,780,630
	RW	Cost for utility work under RW project. See file Utilities Cost Estimate All Segments(AWP).xls	\$2,347,956
	RW	Cost for Right-of-Way. See file HRCS ROW Costs.xlsx	\$19,376,490
	RW	Cost for Right-of-Way for Stormwater Management. See file HRCS ROW Costs.xlsx	\$944,735

Job #	Phase	Comment	Estimate
-------	-------	---------	----------





## Project Cost Estimating System SUMMARY PAGE

<b>DISTRICT</b>	<b>HAMPTON ROADS</b>		
<b>PROJECT NUMBER</b>	<b>64965081</b>		
<b>CONSTRUCTION END YEAR</b>	<b>FY2016</b>	<b>UPC</b>	<b>106724</b>
<b>AD YEAR</b>	<b>FY2016</b>	<small>RATE OF INFLATION TO AD</small>	<b>N/A</b>
<b>ESTIMATE YEAR</b>	<b>FY2016</b>	<small>INFLATION RATE DURING CN</small>	<b>N/A</b>
<small>Date of previous estimate</small>	01/28/16		
<b>PROJECT MANAGER / DESIGNER</b>	<b>Scott.Smizik</b>		
<b>Preliminary Engineering Estimate:</b>	<b>PCES</b>		
<b>Construction Estimate:</b>	<b>PCES</b>		
<b>Right-of-Way Estimate:</b>	<b>MANUAL</b>		
<b>Utilities Estimate:</b>	<b>MANUAL</b>		
<b>DATE</b>	<b>7/12/2016</b>		

THE FOLLOWING DATA WILL BE PROVIDED UPON COMPLETION OF THE REMAINDER OF THE WORKBOOK, WHICH IS ACCESSED BY SELECTING THE CONST, RW, & UTIL TABS BELOW

<b>CONSTRUCTION ESTIMATE</b>	<b>\$364,812,625</b>
<b>PRELIMINARY ENGINEERING ESTIMATE</b>	<b>\$26,492,455</b>
<b>RIGHT-OF-WAY &amp; UTILITIES ESTIMATE</b>	<b>\$41,484,492</b>
<b>TOTAL PROJECT ESTIMATE</b>	<b>\$432,789,572</b>

Project Cost Estimating System  
CONSTRUCTION / BRIDGE / PE

Project No. **64965081**

Interstate Project ?

Route Number   **Interstate Highway**

	CONST-1	CONST-2	Bridges (0)	Total
Geometric Standard	GS-5			
Construction Base	\$195,315,793	\$0	\$130,232,000	\$325,547,793
Bridge Removal			\$0	\$0
CE	\$24,414,474		\$14,850,358	\$39,264,832
Construction Estimate (2016)	\$219,730,267		\$145,082,358	\$364,812,625
To AdYear Inflation				\$0
Mid-point construction Inflation				\$0
Total Construction Estimate			\$145,082,358	<b>\$364,812,625</b>
Preliminary Engineering Cost	\$20,215,185		\$6,277,270	\$26,492,455

### CONSTRUCTION & PE TOTALS

**Total Construction Estimate** **\$364,812,625** **PCES**  
 (Roadway plus Bridge)

**Total Preliminary Engineering Estimate** **\$26,492,455** **PCES**  
 (Roadway plus Bridge)

Project Cost Estimating System

CONSTRUCTION / BRIDGE / PE

Project No. **64965081**

Interstate Project ?	<input type="text" value="Yes"/>	*									
Maintenance Project ?	<input type="text" value="No"/>	*									
Route Number	<input type="text" value="664"/>	*	Interstate Highway								
Select INTERSTATE >	<input type="text" value="GS-5"/>	*	Principal Arterial - Freeway								
Ad Date	<input type="text" value="2016"/>		Design Year = 2038								
Design Year ADT	<input type="text" value="56,700"/>	*	Project Terrain <input type="text" value="Level"/>								
<i>Box Must Be Empty</i>	<input type="text"/>		Approx. DHV = 8,505								
Enter Design Speed (MPH) (Enter 60 or 70)	<input type="text" value="70"/>	*	Minimum Design Speed = 70 MPH								
<i>Box Must Be Empty</i>	<input type="text"/>										
<i>Box Must Be Empty</i>	<input type="text"/>										
Project Length (mi.)	<input type="text" value="5.10"/>	*									
<b>Total Length - Adding or Building Two Lanes (mi.)</b>	<input type="text" value="3.28"/>	*	<table border="0" style="width: 100%;"> <tr> <td style="text-align: center;"><i>Number of Additional Lanes:</i></td> <td style="text-align: center;"><i>Length of Add'l. Lanes (mi.):</i></td> </tr> <tr> <td style="text-align: center;"><input type="text" value="+ One Add'l. Lane"/></td> <td style="text-align: center;"><input type="text" value="0.81"/></td> </tr> <tr> <td style="text-align: center;"><input type="text" value="+ Two Add'l. Lanes"/></td> <td style="text-align: center;"><input type="text" value="0.38"/></td> </tr> <tr> <td style="text-align: center;"><input type="text" value="None"/></td> <td style="text-align: center;"><input type="text"/></td> </tr> </table>	<i>Number of Additional Lanes:</i>	<i>Length of Add'l. Lanes (mi.):</i>	<input type="text" value="+ One Add'l. Lane"/>	<input type="text" value="0.81"/>	<input type="text" value="+ Two Add'l. Lanes"/>	<input type="text" value="0.38"/>	<input type="text" value="None"/>	<input type="text"/>
<i>Number of Additional Lanes:</i>	<i>Length of Add'l. Lanes (mi.):</i>										
<input type="text" value="+ One Add'l. Lane"/>	<input type="text" value="0.81"/>										
<input type="text" value="+ Two Add'l. Lanes"/>	<input type="text" value="0.38"/>										
<input type="text" value="None"/>	<input type="text"/>										
<b>Total Length - Adding or Building Four Lanes (mi.)</b>	<input type="text" value="0.92"/>	*									
<b>Total Length - Building Ramps and Loops (mi.)</b>	<input type="text" value="0.75"/>	*									
Shoulder or Curb & Gutter ? (Select S or C&G)	<input type="text" value="S"/>	*	Enter Lane Width (ft) > <input type="text"/>								
Median Type - Graded, Raised, or None ?	<input type="text" value="N"/>	*	Normal Lane Width(ft) <input type="text" value="12"/>								
Number of Crossovers (Divided Highways ONLY)	<input type="text"/>	*									
Length - Curb & Gutter - Left PLUS Right Side (ft.)	<input type="text"/>										
Length - Sidewalk - Left PLUS Right Side (ft.)	<input type="text"/>										
<b>Bike / Pedestrian Type</b>	<input type="text" value="None"/>										
Total Length - Raised Median (ft.)	<input type="text"/>										
Number of <u>Right Turn Lanes</u> - Left PLUS Right Side	<input type="text"/>	*									
Number of Left Turn Lanes - (Undivided Only)	<input type="text"/>	*									

**HAMPTON ROADS**  
 110% Cost Factor used  
**Construction Costs**

Signals, ITS, Signs and Lighting Costs*	<input type="text" value="\$7,578,486"/>		Base #1 (PCES)	<input type="text" value="\$195,315,793"/>
Cost of Large Drainage Structures	<input type="text" value="\$0"/>		Base #2	<input type="text" value="\$0"/>
In-Plan Utility Costs*	<input type="text" value="\$0"/>		Enter Const CE Cost >	<input type="text" value="\$0"/>
Adjustment for Unusual Construction Costs	<input type="text" value="\$152,987,624"/>		CE (12.5%)	<input type="text" value="\$24,414,474"/>
<i>* Totals include district factor calculations</i>			Estimate (2016)	<input type="text" value="\$219,730,267"/>

Additional (or Unusual) P. E. Costs	<input type="text"/>	
Select % of PE to be performed by Consultants	<input type="text" value="30%"/>	PE Cost (PCES) <input type="text" value="\$20,215,185"/>



**Note: Do Not Include Bridge P. E. Costs Here**

Roadway P. E. / Roadway Const. = 9.2%

© Virginia Department of Transportation 2005  
Revised 01/21/16

**Today's Date: 07/12/16**

**Version 6.00**

**Project Cost Estimating System**  
**Miscellaneous Cost Estimates**

**COST OF LARGE DRAINAGE STRUCTURES**

Job#	Description	Cost ()
<input type="text"/>	<input type="text"/>	<input type="text"/>
<input type="text"/>	<input type="text"/>	<input type="text"/>
<input type="text"/>	<input type="text"/>	<input type="text"/>
<input type="text"/>	<input type="text"/>	<input type="text"/>
<input type="text"/>	<input type="text"/>	<input type="text"/>
		<b>\$0</b>

**ADJUSTMENT FOR UNUSUAL CONSTRUCTION COSTS**

Type	Description	Cost ()
Maintenance of Traffic	20% of roadway costs for MOT	\$20,067,391
Other	5% of roadway and structures costs for landscaping	\$11,528,448
Other	Resurfacing existing roadways	\$9,089,117
Other	Excessive excavation	\$0
Other	Excessive borrow	\$0
Other	Concrete barrier	\$7,401,958
Other	Guardrail and end treatments	\$2,788,955
Other	Removal of existing guardrail	\$57,030
Other	Demolition of existing pavement	\$650,598
Other	Noise barriers	\$22,733,633
Other	Retaining walls	\$19,146,387
Other	Tunnel costs	\$0
Other	Major in-plan utility work (water and sanitary sewer)	\$210,145
Other	Wet ponds and bioretention facilities	\$2,825,000
Environmental	Wetland and stream impacts	\$184,450
Environmental	Historic and archaeological resources	\$500,000
		<input type="text"/>
		<input type="text"/>
Other	40% contingency added to base construction cost	\$55,804,512
		<b>\$152,987,624</b>

Version 6.00

**SIGNALS, ITS, SIGNS and LIGHTING COST WORKSHEET**

Stand Alone Traffic Project:  No

UPC: 106724

**SIGNALS**

Permanent Signals	New/Mod.	Intersection Type	Major				Cross				Poles	Detection	Pre-emption	Cost
			Direction	Lanes	Direction	Lanes	Direction	Lanes	Direction	Lanes				
Location/Description														
1														\$0
2														\$0
3														\$0
4														\$0
5														\$0
6														\$0
7														\$0
8														\$0
9														\$0
10														\$0

Temporary Signals - New Equipment	Quantity	Cost
Temporary Signals - Modified Equipment		\$0

MISCELLANEOUS SIGNAL WORK	Location/Description	Cost
1		
2		

Signals Construction Subtotal \$0

**ITS**

ITS WORK	Location/Description	Cost
1		
2		

ITS Construction Subtotal \$0

**MAJOR SIGN STRUCTURES**

Type of Sign	Comment	Quantity	Unit	Lighted Y/N	Included in Roadway Lighting? yes/no	Cost/Sign	Extended Cost
1	O/H Span (50-100)	2	Ea.	Yes		114,319	\$228,637
2	O/H Span (50-100)	1	Ea.	No		112,819	\$112,819
3	O/H Span (101-200)	5	Ea.	No		200,566	\$1,002,832
4	O/H Span (101-200)	2	Ea.	Yes		203,066	\$406,133
5	Cantilever	2	Ea.	No		56,409	\$112,819
6	Cantilever	1	Ea.	Yes		57,909	\$57,909
7			Ea.				

MISCELLANEOUS SIGN WORK	Location/Description	Cost
1	Add mile post markers at \$1,000/mile for 5.10 miles	\$5,100
2		

Signs Construction Subtotal \$1,926,249

**LIGHTING**

Continuous Roadway		Comments		No. Lanes	Number of Miles	Cost
1	Urban Type of Lighting					\$0
1	Freeway Type of Lighting			8	5.10	\$4,443,174
Interchange		Type of Lighting		Number of Interchanges		Cost
1	Trumpet	Conventional		1		\$520,109
2						\$0
3						\$0
Miscellaneous		Location/Description				Cost
1						
2						

Lighting Construction Subtotal \$4,963,283

**CONSTRUCTION TOTAL \$6,889,532**

*District factor will be applied when the total cost is passed to the const-1 worksheet*

**PROJECT COMMENTS**

Prepared by: CMS

Date Prepared/Modified: 05/05/16

Version 6.00

# BRIDGE CONSTRUCTION AND PRELIMINARY ENGINEERING COSTS

BRIDGE  
CONSTRUCTION

BRIDGE  
P. E.

Bridge Job #

Federal Structure ID

Manual CEI Cost Override :

Bridge # 1 CEI Cost :

16%

Manual PE Cost Adjustment :

Bridge #1 CN + CEI Cost :

P.E. Bridge # 1

BRIDGE #1 CN Cost : (input from Bridge PCES worksheet)

Comments - Constr. Engr. Br. #1:

Comments - Misc. P.E. Bridge #1:

Bridge Job #

Federal Structure ID

Manual CEI Cost Override :

Bridge # 2 CEI Cost :

14.0%

Manual PE Cost Adjustment :

Bridge #2 CN + CEI Cost :

P.E. Bridge # 2

BRIDGE #2 CN Cost : (input from Bridge PCES worksheet)

Comments - Constr. Engr. Br. #2:

Comments - Misc. P.E. Bridge #2:

Bridge Job #

Federal Structure ID

Manual CEI Cost Override :

Bridge # 3 CEI Cost :   
14.0%

Manual PE Cost Adjustment :

BRIDGE #3 CN Cost : (input from Bridge PCES worksheet)

Bridge #3 CN + CEI Cost :

P.E. Bridge # 3

Comments - Constr. Engr. Br. #3:

Comments - Misc. P.E. Bridge #3:



BRIDGE CONSTRUCTION AND PE COSTS (continued)

**BRIDGE  
CONSTRUCTION**

**BRIDGE  
P. E.**

Bridge Job #

Federal Structure ID

Manual CEI Cost Override :

Bridge # 4 CEI Cost :

15.0%

Manual PE Cost Adjustment :

BRIDGE #4 CN Cost : (input from Bridge PCES worksheet)

Bridge #4 CN + CEI Cost :

P.E. Bridge # 4

Comments - Constr. Engr. Br. #4:

Comments - Misc. P.E. Bridge #4:

Bridge Job #

Federal Structure ID

Manual CEI Cost Override :

Bridge # 5 CEI Cost :

16.0%

Manual PE Cost Adjustment :

BRIDGE #5 CN Cost : (input from Bridge PCES worksheet)

Bridge #5 CN + CEI Cost :

P.E. Bridge # 5

Comments - Constr. Engr. Br. #5:

Comments - Misc. P.E. Bridge #5:

Bridge Job #

Federal Structure ID

Manual CEI Cost Override :

Bridge # 6 CEI Cost :

**\$1,936,440**

11.0%

Manual PE Cost Adjustment :

**\$674,839**

BRIDGE #6 CN Cost : (input from Bridge PCES worksheet)

**\$17,604,000**

Bridge #6 CN + CEI Cost :

**\$19,540,440**

P.E. Bridge # 6

**\$674,839**

Comments - Constr. Engr. Br. #6:

Comments - Misc. P.E. Bridge #6:

BRIDGE CONSTRUCTION AND PE COSTS (continued)

BRIDGE CONSTRUCTION

BRIDGE P. E.

Bridge Job #

[Yellow box]

Federal Structure ID

20742

Manual CEI Cost Override :

[Yellow box]

Bridge # 7 CEI Cost : \$454,750

12.5%

Manual PE Cost Adjustment :

[Yellow box]

Bridge #7 CN + CEI Cost :

\$4,092,750

P.E. Bridge # 7

BRIDGE #7 CN Cost : (input from Bridge PCES worksheet) \$3,638,000

\$235,608

Comments - Constr. Engr. Br. #7:

[White box]

Comments - Misc. P.E. Bridge #7:

[White box]

Bridge Job #

[Yellow box]

Federal Structure ID

20744

Manual CEI Cost Override :

[Yellow box]

Bridge # 8 CEI Cost : \$91,970

17.0%

Manual PE Cost Adjustment :

[Yellow box]

Bridge #8 CN + CEI Cost :

\$632,970

P.E. Bridge # 8

BRIDGE #8 CN Cost : (input from Bridge PCES worksheet) \$541,000

\$138,207

Comments - Constr. Engr. Br. #8:

[White box]

Comments - Misc. P.E. Bridge #8:

[White box]

Bridge Job #

[Yellow box]

Federal Structure ID

26

Manual CEI Cost Override :

Bridge # 9 CEI Cost :

*11.0%*

Manual PE Cost Adjustment :

BRIDGE #9 CN Cost : (input from Bridge PCES worksheet)

Bridge #9 CN + CEI Cost :

P.E. Bridge # 9

Comments - Constr. Engr. Br. #9:

Comments - Misc. P.E. Bridge #9:

BRIDGE CONSTRUCTION AND PE COSTS (continued)

BRIDGE CONSTRUCTION

BRIDGE P. E.

Bridge Job #

[Yellow box]

Federal Structure ID

20647

Manual CEI Cost Override :

[Yellow box]

Bridge # 10 CEI Cost :

\$1,871,870

11.0%

Manual PE Cost Adjustment :

[Yellow box]

Bridge #10 CN + CEI Cost :

\$18,888,870

P.E. Bridge # 10

\$656,378

BRIDGE #10 CN Cost : (input from Bridge PCES worksheet)

\$17,017,000

Comments - Constr. Engr. Br. #10:

[White box]

Comments - Misc. P.E. Bridge #10:

[White box]

Bridge Job #

[Yellow box]

Federal Structure ID

20649

Manual CEI Cost Override :

[Yellow box]

Bridge # 11 CEI Cost :

\$1,196,030

11.0%

Manual PE Cost Adjustment :

[Yellow box]

Bridge #11 CN + CEI Cost :

\$12,069,030

P.E. Bridge # 11

\$463,149

BRIDGE #11 CN Cost : (input from Bridge PCES worksheet)

\$10,873,000

Comments - Constr. Engr. Br. #11:

[White box]

Comments - Misc. P.E. Bridge #11:

[White box]

Bridge Job #

[Yellow box]

Federal Structure ID

20663

Manual CEI Cost Override :

[Yellow box]

Bridge # 12 CEI Cost : \$1,561,450  
11.0%

Manual PE Cost Adjustment :

BRIDGE #12 CN Cost : (input from Bridge PCES worksheet) \$14,195,000

Bridge #12 CN + CEI Cost : \$15,756,450

P.E. Bridge # 12 \$567,626

Comments - Constr. Engr. Br. #12:

Comments - Misc. P.E. Bridge #12:

BRIDGE CONSTRUCTION AND PE COSTS (continued)

BRIDGE CONSTRUCTION

BRIDGE P. E.

Bridge Job #

[Yellow box]

Federal Structure ID

29306

Manual CEI Cost Override :

[Yellow box]

Bridge # 13 CEI Cost :

\$496,800

12.0%

Manual PE Cost Adjustment :

[Yellow box]

Bridge #13 CN + CEI Cost :

\$4,636,800

P.E. Bridge # 13

BRIDGE #13 CN Cost : (input from Bridge PCES worksheet)

\$4,140,000

\$251,396

Comments - Constr. Engr. Br. #13:

[White box]

Comments - Misc. P.E. Bridge #13:

[White box]

Bridge Job #

[Yellow box]

Federal Structure ID

20651

Manual CEI Cost Override :

[Yellow box]

Bridge # 14 CEI Cost :

\$1,260,270

11.0%

Manual PE Cost Adjustment :

[Yellow box]

Bridge #14 CN + CEI Cost :

\$12,717,270

P.E. Bridge # 14

BRIDGE #14 CN Cost : (input from Bridge PCES worksheet)

\$11,457,000

\$481,516

Comments - Constr. Engr. Br. #14:

[White box]

Comments - Misc. P.E. Bridge #14:

[White box]

Bridge Job #

[Yellow box]

Federal Structure ID

29307, 29405, 20653, 20296

Manual CEI Cost Override :

[Yellow box]

Bridge # 15 CEI Cost : \$3,105,428  
\$3,105,428  
*11.0%*

Manual PE Cost Adjustment : \$363,579

BRIDGE #15 CN Cost : (input from Bridge PCES worksheet) \$27,617,000 Bridge #15 CN + CEI Cost : \$30,722,428 P.E. Bridge # 15 \$1,353,327



Comments - Constr. Engr. Br. #15:

Comments - Misc. P.E. Bridge #15:



BRIDGE CONSTRUCTION AND PE COSTS (continued)			
		<i>Bridge Construction Base (PCES)</i>	\$130,232,000
<i>Bike / PED Construction Cost</i>	\$0		
<i>Bike / PED CE</i>	\$0	<i>Bridge Removal</i>	\$0
<i>Bike / PED PE</i>	\$0	<i>Bridge CE (PCES)</i>	\$14,850,358
<b>NOTE : Structure Complexity is based upon Height,</b>		<b>Bridge Estimate. (2016)</b>	<b>\$145,082,358</b>
<b>Difficulty of Construction, and other Factors</b>		<b>Total Bridge P. E. Costs (PCES)</b>	<b>\$6,277,270</b>

Version 6.00

 <b>Project Cost Estimating System</b>  <b>COMMENTS</b>		
<b>General / Miscellaneous Comments from CONST, RW, &amp; UTILITY Worksheets</b>	<b>Team Member and Section</b>	<b>Date Entered</b>
<b>1</b> Project terrain changed from rolling to level based on comments from L&D on draft cost estimate	C. Sutkowski - HRCS Team	06/23/16
<b>2</b> Moved 10% of roadway and structures costs for general utility relocation from CONST-MISC sheet to MANUAL sheet	C. Sutkowski - HRCS Team	06/27/16
<b>3</b> Input revised bridge costs based on comments from S&B on draft cost estimate	C. Sutkowski - HRCS Team	06/28/16
<b>4</b> Included costs for noise barriers in segment estimate as provided by noise team	C. Sutkowski - HRCS Team	06/29/16
<b>5</b> Updated costs for right-of-way with contingency added in line item in MANUAL sheet	C. Sutkowski - HRCS Team	06/29/16
<b>6</b> Added costs for right-of-way for stormwater management in MANUAL sheet	C. Sutkowski - HRCS Team	06/29/16
<b>7</b>		
<b>8</b>		
<b>9</b>		
<b>10</b>		
<b>11</b>		
<b>12</b>		
<b>13</b>		
<b>14</b>		
<b>15</b>		

**VDOT Project Cost Estimating System  
MANUAL ESTIMATE**

	DATE	PE	RW	CN
<b>EXPENDITURES</b>	01/20/16	\$839,552		\$0
<b>RUMS</b>	01/28/16			\$0
<b>TRNS*PORT</b>				\$0
<b>AWARD</b>	01/28/16			\$0
<b>PROJECTION</b>	01/28/16			\$0

**ESTIMATE YEAR**

**AD YEAR**

FY2016		FY2016
\$0	PE	\$0
\$41,484,492	RW	\$41,484,492
\$0	CN	\$0
\$41,484,492	<b>TOTAL</b>	\$41,484,492

Job #	Phase	Comment	Estimate
	RW	10% of roadway and structures costs for general utility relocation	\$23,056,896
	RW	Cost for utility work under RW project. See file Utilities Cost Estimate All Segments(AWP).xls	\$2,347,956
	RW	Cost for Right-of-Way. See file HRCS ROW Costs.xlsx	\$15,374,668
	RW	Cost for Right-of-Way for Stormwater Management. See file HRCS ROW Costs.xlsx	\$704,973

Job #	Phase	Comment	Estimate
-------	-------	---------	----------



## Project Cost Estimating System SUMMARY PAGE

<b>DISTRICT</b>	<b>HAMPTON ROADS</b>		
<b>PROJECT NUMBER</b>	<b>64965081</b>		
<b>CONSTRUCTION END YEAR</b>	<b>FY2016</b>	<b>UPC</b>	<b>106724</b>
<b>AD YEAR</b>	<b>FY2016</b>	<small>RATE OF INFLATION TO AD</small>	<b>N/A</b>
<b>ESTIMATE YEAR</b>	<b>FY2016</b>	<small>INFLATION RATE DURING CN</small>	<b>N/A</b>
<small>Date of previous estimate</small>	01/28/16		
<b>PROJECT MANAGER / DESIGNER</b>	<b>Scott.Smizik</b>		
<b>Preliminary Engineering Estimate:</b>	<b>PCES</b>		
<b>Construction Estimate:</b>	<b>PCES</b>		
<b>Right-of-Way Estimate:</b>	<b>MANUAL</b>		
<b>Utilities Estimate:</b>	<b>MANUAL</b>		
<b>DATE</b>	<b>6/30/2016</b>		

THE FOLLOWING DATA WILL BE PROVIDED UPON COMPLETION OF THE REMAINDER OF THE WORKBOOK, WHICH IS ACCESSED BY SELECTING THE CONST, RW, & UTIL TABS BELOW



<b>CONSTRUCTION ESTIMATE</b>	<b>\$54,629,062</b>
<b>PRELIMINARY ENGINEERING ESTIMATE</b>	<b>\$4,958,083</b>
<b>RIGHT-OF-WAY &amp; UTILITIES ESTIMATE</b>	<b>\$4,426,957</b>
<b>TOTAL PROJECT ESTIMATE</b>	<b>\$64,014,102</b>

© Virginia Department of Transportation 2005

Revised 01/21/16

Estimate Class: Blank

Version 6.00

Project Cost Estimating System
  
**CONSTRUCTION / BRIDGE / PE**

Project No. **64965081**

Interstate Project ?

Route Number   **Interstate Highway**

	CONST-1	CONST-2	Bridges (0)	Total
Geometric Standard	GS-5			
Construction Base	\$44,263,872	\$0	\$4,273,000	\$48,536,872
Bridge Removal			\$0	\$0
CE	\$5,532,984		\$559,205	\$6,092,189
Construction Estimate (2016)	\$49,796,857		\$4,832,205	\$54,629,062
To AdYear Inflation				\$0
Mid-point construction Inflation				\$0
Total Construction Estimate			\$4,832,205	<b>\$54,629,062</b>
Preliminary Engineering Cost	\$4,581,311		\$376,772	\$4,958,083

### CONSTRUCTION & PE TOTALS

**Total Construction Estimate** **\$54,629,062** PCES  
 (Roadway plus Bridge)

**Total Preliminary Engineering Estimate** **\$4,958,083** PCES  
 (Roadway plus Bridge)

Project Cost Estimating System

CONSTRUCTION / BRIDGE / PE

Project No. **64965081**

Interstate Project ?	<input type="text" value="Yes"/>	*									
Maintenance Project ?	<input type="text" value="No"/>	*									
Route Number	<input type="text" value="64"/>	*	Interstate Highway								
Select INTERSTATE >	<input type="text" value="GS-5"/>	*	Principal Arterial - Freeway								
Ad Date	<input type="text" value="2016"/>		Design Year = 2038								
Design Year ADT	<input type="text" value="72,100"/>	*	Project Terrain <input type="text" value="Level"/>								
<i>Box Must Be Empty</i>	<input type="text"/>		Approx. DHV = 10,815								
Enter Design Speed (MPH) (Enter 60 or 70)	<input type="text" value="70"/>	*	Minimum Design Speed = 70 MPH								
<i>Box Must Be Empty</i>	<input type="text"/>										
<i>Box Must Be Empty</i>	<input type="text"/>										
Project Length (mi.)	<input type="text" value="1.02"/>	*									
Total Length - Adding or Building <u>Two Lanes</u> (mi.)	<input type="text" value="0.45"/>	*	<table border="0" style="width: 100%; font-size: small;"> <tr> <td style="text-align: center;"><i>Number of Additional Lanes:</i></td> <td style="text-align: center;"><i>Length of Add'l. Lanes (mi.):</i></td> </tr> <tr> <td style="text-align: center;"><b>+ One Add'l. Lane</b></td> <td style="text-align: center;"><input type="text" value="0.86"/></td> </tr> <tr> <td style="text-align: center;">None</td> <td style="text-align: center;"><input type="text"/></td> </tr> <tr> <td style="text-align: center;">None</td> <td style="text-align: center;"><input type="text"/></td> </tr> </table>	<i>Number of Additional Lanes:</i>	<i>Length of Add'l. Lanes (mi.):</i>	<b>+ One Add'l. Lane</b>	<input type="text" value="0.86"/>	None	<input type="text"/>	None	<input type="text"/>
<i>Number of Additional Lanes:</i>	<i>Length of Add'l. Lanes (mi.):</i>										
<b>+ One Add'l. Lane</b>	<input type="text" value="0.86"/>										
None	<input type="text"/>										
None	<input type="text"/>										
Total Length - Adding or Building <u>Four Lanes</u> (mi.)	<input type="text"/>	*	None								
Total Length - Building <u>Ramps and Loops</u> (mi.)	<input type="text"/>	*	None								
Shoulder or Curb & Gutter ? (Select S or C&G)	<input type="text" value="S"/>	*	Enter Lane Width (ft) > <input type="text"/>								
Median Type - Graded, Raised, or None ?	<input type="text" value="N"/>	*	Normal Lane Width(ft) <input type="text" value="12"/>								
Number of Crossovers (Divided Highways ONLY)	<input type="text"/>	*									
Length - Curb & Gutter - Left PLUS Right Side (ft.)	<input type="text"/>										
Length - Sidewalk - Left PLUS Right Side (ft.)	<input type="text"/>										
Bike / Pedestrian Type	<input type="text" value="None"/>										
Total Length - Raised Median (ft.)	<input type="text"/>										
Number of <u>Right Turn Lanes</u> - Left PLUS Right Side	<input type="text"/>	*									
Number of Left Turn Lanes - (Undivided Only)	<input type="text"/>	*									

**HAMPTON ROADS**  
 110% Cost Factor used  
**Construction Costs**

Signals, ITS, Signs and Lighting Costs*	<input type="text" value="\$3,673,598"/>	
Cost of Large Drainage Structures	<input type="text" value="\$0"/>	Base #1 (PCES) <input type="text" value="\$44,263,872"/>
In-Plan Utility Costs*	<input type="text" value="\$0"/>	Base #2 <input type="text" value="\$0"/>
Adjustment for Unusual Construction Costs	<input type="text" value="\$36,244,529"/>	Enter Const CE Cost > <input type="text" value="\$0"/>
		CE (12.5%) <input type="text" value="\$5,532,984"/>
		Estimate (2016) <input type="text" value="\$49,796,857"/>

\* Totals include district factor calculations

Additional (or Unusual) P. E. Costs	<input type="text"/>	
Select % of PE to be performed by Consultants	<input type="text" value="30%"/>	PE Cost (PCES) <input type="text" value="\$4,581,311"/>



**Note: Do Not Include Bridge P. E. Costs Here**

Roadway P. E. / Roadway Const. = 9.2%

© Virginia Department of Transportation 2005  
Revised 01/21/16

**Today's Date: 06/30/16**

**Version 6.00**

	<b>Project Cost Estimating System</b> <b>Miscellaneous Cost Estimates</b>	
---	--	---

**COST OF LARGE DRAINAGE STRUCTURES**

Job#	Description	Cost ()
		<b>\$0</b>

**ADJUSTMENT FOR UNUSUAL CONSTRUCTION COSTS**

Type	Description	Cost ()
Maintenance of Traffic	20% of roadway costs for MOT	\$4,436,769
Other	5% of roadway and structures costs for landscaping	\$1,322,842
Other	Resurfacing existing roadways	\$1,054,522
Other	Excessive excavation	\$0
Other	Excessive borrow	\$0
Other	Concrete barrier	\$666,883
Other	Guardrail and end treatments	\$293,816
Other	Removal of existing guardrail	\$11,032
Other	Demolition of existing pavement	\$122,820
Other	Noise barriers	\$9,908,178
Other	Retaining walls	\$789,950
Other	Tunnel costs	\$0
Other	Major in-plan utility work (water and sanitary sewer)	\$20,245
Other	Wet ponds and bioretention facilities	\$1,450,000
Environmental	Wetland and stream impacts	\$20,650
Environmental	Historic and archaeological resources	\$3,500,000
Other	40% contingency added to base construction cost	\$12,646,821
		<b>\$36,244,529</b>

Version 6.00



**SIGNALS, ITS, SIGNS and LIGHTING COST WORKSHEET**

Stand Alone Traffic Project:  No

UPC: 106724

**SIGNALS**

Permanent Signals	New/Mod.	Intersection Type	Major				Cross				Poles	Detection	Pre-emption	Cost
			Direction	Lanes	Direction	Lanes	Direction	Lanes	Direction	Lanes				
Location/Description														
1														\$0
2														\$0
3														\$0
4														\$0
5														\$0
6														\$0
7														\$0
8														\$0
9														\$0
10														\$0

Temporary Signals - New Equipment	Quantity	Cost
Temporary Signals - Modified Equipment		\$0

MISCELLANEOUS SIGNAL WORK	Location/Description	Cost
1		
2		

Signals Construction Subtotal \$0

**ITS**

ITS WORK	Location/Description	Cost
1		
2		

ITS Construction Subtotal \$0

**MAJOR SIGN STRUCTURES**

Type of Sign	Comment	Quantity	Unit	Lighted Y/N	Included in Roadway Lighting? yes/no	Cost/Sign	Extended Cost
1	O/H Span (50-100)	5	Ea.	Yes	<input type="checkbox"/>	114,319	\$571,593
2	O/H Span (50-100)	2	Ea.	No	<input type="checkbox"/>	112,819	\$225,637
3	O/H Span (101-200)	5	Ea.	Yes	<input type="checkbox"/>	203,066	\$1,015,332
4	O/H Span (101-200)	4	Ea.	No	<input type="checkbox"/>	200,566	\$802,266
5	Cantilever	2	Ea.	Yes	<input type="checkbox"/>	57,909	\$115,819
6	Cantilever	1	Ea.	No	<input type="checkbox"/>	56,409	\$56,409
7			Ea.				

MISCELLANEOUS SIGN WORK	Location/Description	Cost
1	Add mile post markers at \$1,000/mile for 1.02 miles	\$1,020
2		

Signs Construction Subtotal \$2,788,077

**LIGHTING**

Continuous Roadway		Urban Type of Lighting	Comments	No. Lanes	Number of Miles	Cost
1				<input type="checkbox"/>	<input type="checkbox"/>	\$0
Freeway		Freeway Type of Lighting	Comments	No. Lanes	Number of Miles	Cost
1		Conventional		6	1.00	\$551,558
Interchange		Interchange Type	Type of Lighting		Number of Interchanges	Cost
1						\$0
2						\$0
3						\$0
Miscellaneous		Location/Description				Cost
1						
2						

Lighting Construction Subtotal \$551,558

**CONSTRUCTION TOTAL \$3,339,635**

*District factor will be applied when the total cost is passed to the const-1 worksheet*

**PROJECT COMMENTS**

Prepared by: CMS

Date Prepared/Modified: 05/05/16

Version 6.00

# BRIDGE CONSTRUCTION AND PRELIMINARY ENGINEERING COSTS

BRIDGE  
CONSTRUCTION

BRIDGE  
P. E.

Bridge Job #

Federal Structure ID

Manual CEI Cost Override :

Bridge # 1 CEI Cost :

18%

Manual PE Cost Adjustment :

Bridge #1 CN + CEI Cost :

P.E. Bridge # 1

BRIDGE #1 CN Cost : (input from Bridge PCES worksheet)

Comments - Constr. Engr. Br. #1:

Comments - Misc. P.E. Bridge #1:

Bridge Job #

Federal Structure ID

Manual CEI Cost Override :

Bridge # 2 CEI Cost :

12.5%

Manual PE Cost Adjustment :

Bridge #2 CN + CEI Cost :

P.E. Bridge # 2

BRIDGE #2 CN Cost : (input from Bridge PCES worksheet)

Comments - Constr. Engr. Br. #2:



Comments - Misc. P.E. Bridge #2:

Bridge Job #

Federal Structure ID

BRIDGE CONSTRUCTION AND PE COSTS (continued)			
		<i>Bridge Construction Base (PCES)</i>	\$4,273,000
<i>Bike / PED Construction Cost</i>	\$0		
<i>Bike / PED CE</i>	\$0	<i>Bridge Removal</i>	\$0
<i>Bike / PED PE</i>	\$0	<i>Bridge CE (PCES)</i>	\$559,205
<b>NOTE : Structure Complexity is based upon Height,</b>		<b>Bridge Estimate. (2016)</b>	<b>\$4,832,205</b>
<b>Difficulty of Construction, and other Factors</b>		<b>Total Bridge P. E. Costs (PCES)</b>	<b>\$376,772</b>

Version 6.00

 Project Cost Estimating System <b>COMMENTS</b> 		
<b>General / Miscellaneous Comments from CONST, RW, &amp; UTILITY Worksheets</b>	<b>Team Member and Section</b>	<b>Date Entered</b>
<b>1</b> Project terrain changed from rolling to level based on comments from L&D on draft cost estimate	C. Sutkowski - HRCS Team	06/23/16
<b>2</b> Moved 10% of roadway and structures costs for general utility relocation from CONST-MISC sheet to MANUAL sheet	C. Sutkowski - HRCS Team	06/27/16
<b>3</b> Input revised bridge costs based on comments from S&B on draft cost estimate	C. Sutkowski - HRCS Team	06/28/16
<b>4</b> Included costs for noise barriers in segment estimate as provided by noise team	C. Sutkowski - HRCS Team	06/29/16
<b>5</b> Updated costs for right-of-way with contingency added in line item in MANUAL sheet	C. Sutkowski - HRCS Team	06/29/16
<b>6</b> Added costs for right-of-way for stormwater management in MANUAL sheet	C. Sutkowski - HRCS Team	06/29/16
<b>7</b>		
<b>8</b>		
<b>9</b>		
<b>10</b>		
<b>11</b>		
<b>12</b>		
<b>13</b>		
<b>14</b>		
<b>15</b>		

**VDOT Project Cost Estimating System  
MANUAL ESTIMATE**

	DATE	PE	RW	CN
<b>EXPENDITURES</b>	01/20/16	\$839,552		\$0
<b>RUMS</b>	01/28/16			\$0
<b>TRNS*PORT</b>				\$0
<b>AWARD</b>	01/28/16			\$0
<b>PROJECTION</b>	01/28/16			\$0

**ESTIMATE YEAR**

**AD YEAR**

FY2016		FY2016
\$0	PE	\$0
\$4,426,957	RW	\$4,426,957
\$0	CN	\$0
\$4,426,957	<b>TOTAL</b>	\$4,426,957

Job #	Phase	Comment	Estimate
	RW	10% of roadway and structures costs for general utility relocation	\$2,645,684
	RW	Cost for utility work under RW project. See file Utilities Cost Estimate All Segments(AWP).xls	\$201,250
	RW	Cost for Right-of-Way. See file HRCS ROW Costs.xlsx	\$1,254,673
	RW	Cost for Right-of-Way for Stormwater Management. See file HRCS ROW Costs.xlsx	\$325,350

Job #	Phase	Comment	Estimate
-------	-------	---------	----------



## Project Cost Estimating System SUMMARY PAGE

<b>DISTRICT</b>	<b>HAMPTON ROADS</b>		
<b>PROJECT NUMBER</b>	<b>64965081</b>		
<b>CONSTRUCTION END YEAR</b>	<b>FY2016</b>	<b>UPC</b>	<b>106724</b>
<b>AD YEAR</b>	<b>FY2016</b>	<small>RATE OF INFLATION TO AD</small>	<b>N/A</b>
<b>ESTIMATE YEAR</b>	<b>FY2016</b>	<small>INFLATION RATE DURING CN</small>	<b>N/A</b>

Date of previous estimate 01/28/16



**PROJECT MANAGER / DESIGNER** **Scott.Smizik**

Preliminary Engineering Estimate:	<b>PCES</b>
Construction Estimate:	<b>PCES</b>
Right-of-Way Estimate:	<b>MANUAL</b>
Utilities Estimate:	<b>MANUAL</b>

**DATE** 6/30/2016

THE FOLLOWING DATA WILL BE PROVIDED UPON COMPLETION OF THE REMAINDER OF THE WORKBOOK, WHICH IS ACCESSED BY SELECTING THE CONST, RW, & UTIL TABS BELOW

<b>CONSTRUCTION ESTIMATE</b>	<b>\$2,870,535,564</b>
<b>PRELIMINARY ENGINEERING ESTIMATE</b>	<b>\$232,640,704</b>
<b>RIGHT-OF-WAY &amp; UTILITIES ESTIMATE</b>	<b>\$64,352,205</b>
<b>TOTAL PROJECT ESTIMATE</b>	<b>\$3,167,528,473</b>

	Project Cost Estimating System CONSTRUCTION / BRIDGE / PE	
---	--	---

Project No. **64965081**

Interstate Project ?

Route Number   **Interstate Highway**

	CONST-1	CONST-2	Bridges (0)	Total
Geometric Standard	GS-5			
Construction Base	\$2,068,848,848	\$0	\$488,516,000	\$2,557,364,848
Bridge Removal			\$0	\$0
CE	\$258,606,106		\$54,564,610	\$313,170,716
Construction Estimate (2016)	\$2,327,454,954		\$543,080,610	\$2,870,535,564
To AdYear Inflation				\$0
Mid-point construction Inflation				\$0
Total Construction Estimate			\$543,080,610	<b>\$2,870,535,564</b>
Preliminary Engineering Cost	\$214,125,856		\$18,514,848	\$232,640,704

### CONSTRUCTION & PE TOTALS

<p><b>Total Construction Estimate</b> (Roadway plus Bridge)</p>	<p><b>\$2,870,535,564</b></p>	<p><b>PCES</b></p>
<p><b>Total Preliminary Engineering Estimate</b> (Roadway plus Bridge)</p>	<p><b>\$232,640,704</b></p>	<p><b>PCES</b></p>

Project Cost Estimating System

CONSTRUCTION / BRIDGE / PE

Project No. **64965081**

Interstate Project ?	<input type="text" value="Yes"/>	*									
Maintenance Project ?	<input type="text" value="No"/>	*									
Route Number	<input type="text" value="64"/>	*	Interstate Highway								
Select INTERSTATE >	<input type="text" value="GS-5"/>	*	Principal Arterial - Freeway								
Ad Date	<input type="text" value="2016"/>		Design Year = 2038								
Design Year ADT	<input type="text" value="68,900"/>	*	Project Terrain <input type="text" value="Level"/>								
<i>Box Must Be Empty</i>	<input type="text"/>		Approx. DHV = 10,335								
Enter Design Speed (MPH) (Enter 60 or 70)	<input type="text" value="70"/>	*	Minimum Design Speed = 70 MPH								
<i>Box Must Be Empty</i>	<input type="text"/>										
<i>Box Must Be Empty</i>	<input type="text"/>										
Project Length (mi.)	<input type="text" value="8.25"/>	*	<table border="0" style="width: 100%; font-size: small;"> <tr> <td style="text-align: center;"><i>Number of Additional Lanes:</i></td> <td style="text-align: center;"><i>Length of Add'l. Lanes (mi.):</i></td> </tr> <tr> <td style="text-align: center;"><input type="text" value="+ One Add'l. Lane"/></td> <td style="text-align: center;"><input type="text" value="0.20"/></td> </tr> <tr> <td style="text-align: center;"><input type="text" value="None"/></td> <td style="text-align: center;"><input type="text"/></td> </tr> <tr> <td style="text-align: center;"><input type="text" value="None"/></td> <td style="text-align: center;"><input type="text"/></td> </tr> </table>	<i>Number of Additional Lanes:</i>	<i>Length of Add'l. Lanes (mi.):</i>	<input type="text" value="+ One Add'l. Lane"/>	<input type="text" value="0.20"/>	<input type="text" value="None"/>	<input type="text"/>	<input type="text" value="None"/>	<input type="text"/>
<i>Number of Additional Lanes:</i>	<i>Length of Add'l. Lanes (mi.):</i>										
<input type="text" value="+ One Add'l. Lane"/>	<input type="text" value="0.20"/>										
<input type="text" value="None"/>	<input type="text"/>										
<input type="text" value="None"/>	<input type="text"/>										
Total Length - Adding or Building <u>Two Lanes</u> (mi.)	<input type="text" value="3.12"/>	*									
Total Length - Adding or Building <u>Four Lanes</u> (mi.)	<input type="text" value="0.22"/>	*									
Total Length - Building <u>Ramps and Loops</u> (mi.)	<input type="text" value="0.78"/>	*									
Shoulder or Curb & Gutter ? (Select S or C&G)	<input type="text" value="S"/>	*	Enter Lane Width (ft) > <input type="text"/>								
Median Type - Graded, Raised, or None ?	<input type="text" value="G"/>	*	Normal Lane Width(ft) <input type="text" value="12"/>								
Number of Crossovers (Divided Highways ONLY)	<input type="text"/>	*									
Length - Curb & Gutter - Left PLUS Right Side (ft.)	<input type="text"/>										
Length - Sidewalk - Left PLUS Right Side (ft.)	<input type="text"/>										
Bike / Pedestrian Type	<input type="text" value="None"/>										
Total Length - Raised Median (ft.)	<input type="text"/>										
Number of <u>Right Turn Lanes</u> - Left PLUS Right Side	<input type="text"/>	*									
Number of Left Turn Lanes - (Undivided Only)	<input type="text"/>	*									

**HAMPTON ROADS**  
 110% Cost Factor used

<b>Construction Costs</b>	
Base #1 (PCES)	<input type="text" value="\$2,068,848,848"/>
Base #2	<input type="text" value="\$0"/>
Enter Const CE Cost >	<input type="text" value="\$0"/>
CE (12.5%)	<input type="text" value="\$258,606,106"/>
Estimate (2016)	<input type="text" value="\$2,327,454,954"/>

Signals, ITS, Signs and Lighting Costs*	<input type="text" value="\$7,688,427"/>
Cost of Large Drainage Structures	<input type="text" value="\$275,900"/>
In-Plan Utility Costs*	<input type="text" value="\$0"/>
Adjustment for Unusual Construction Costs	<input type="text" value="\$2,035,199,376"/>

\* Totals include district factor calculations

Additional (or Unusual) P. E. Costs	<input type="text"/>	
Select % of PE to be performed by Consultants	<input type="text" value="30%"/>	PE Cost (PCES) <input type="text" value="\$214,125,856"/>





**Note: Do Not Include Bridge P. E. Costs Here**

Roadway P. E. / Roadway Const. = 9.2%

© Virginia Department of Transportation 2005  
Revised 01/21/16

**Today's Date: 06/30/16**

**Version 6.00**

	<b>Project Cost Estimating System</b> <b>Miscellaneous Cost Estimates</b>	
---	--	---

**COST OF LARGE DRAINAGE STRUCTURES**

Job#	Description	Cost ()
XXXXXX	Culvert extension under I-64, 0.2 mi west of 4th View St	\$275,900
		<b>\$275,900</b>

**ADJUSTMENT FOR UNUSUAL CONSTRUCTION COSTS**

Type	Description	Cost ()
Maintenance of Traffic	20% of roadway costs for MOT	\$14,341,592
Other	5% of roadway and structures costs for landscaping	\$28,011,198
Other	Resurfacing existing roadways	\$10,429,873
Other	Excessive excavation	\$0
Other	Excessive borrow	\$0
Other	Concrete barrier	\$4,770,981
Other	Guardrail and end treatments	\$2,058,567
Other	Removal of existing guardrail	\$89,226
Other	Demolition of existing pavement	\$285,205
Other	Noise barriers	\$19,159,888
Other	Retaining walls	\$1,892,366
Other	Tunnel costs	\$1,356,000,000
Other	Major in-plan utility work (water and sanitary sewer)	\$1,958,110
Other	Wet ponds and bioretention facilities	\$2,350,000
Environmental	Wetland and stream impacts	\$252,700
Environmental	Historic and archaeological resources	\$2,500,000
Other	40% contingency added to base construction cost	\$591,099,671
		<b>\$2,035,199,376</b>

Version 6.00

**SIGNALS, ITS, SIGNS and LIGHTING COST WORKSHEET**

Stand Alone Traffic Project:  No

UPC: 106724

Permanent Signals	New/Mod.	Intersection Type	Major				Cross				Poles	Detection	Pre-emption	Cost
			Direction	Lanes	Direction	Lanes	Direction	Lanes	Direction	Lanes				
Location/Description														
1														\$0
2														\$0
3														\$0
4														\$0
5														\$0
6														\$0
7														\$0
8														\$0
9														\$0
10														\$0

Temporary Signals - New Equipment	Quantity	Cost
Temporary Signals - Modified Equipment		\$0

MISCELLANEOUS SIGNAL WORK	Location/Description	Cost
1		
2		

Signals Construction Subtotal \$0

ITS WORK	Location/Description	Cost
1		
2		

ITS Construction Subtotal \$0

MAJOR SIGN STRUCTURES	Type of Sign	Comment	Quantity	Unit	Lighted Y/N	Included in Roadway Lighting? yes/no	Cost/Sign	Extended Cost
1	O/H Span (50-100)		17	Ea.	Yes		114,319	\$1,943,417
2	O/H Span (50-100)		4	Ea.	No		112,819	\$451,275
3	O/H Span (101-200)		1	Ea.	No		200,566	\$200,566
4	O/H Span (101-200)		1	Ea.	Yes		203,066	\$203,066
5	O/H Span (101-200)	Signs at ends of tunnel	2	Ea.	Yes		203,066	\$406,133
6				Ea.				
7				Ea.				

MISCELLANEOUS SIGN WORK	Location/Description	Cost
1	Add mile post markers at \$1,000/mile for 6.85 miles	\$6,850
2		

Signs Construction Subtotal \$3,211,308

Continuous Roadway				No. Lanes	Number of Miles	Cost
1	Urban Type of Lighting	Comments				\$0
1	Freeway Type of Lighting	Comments		6	6.85	\$3,778,171
Interchange				No. Lanes	Number of Interchanges	Cost
1	Interchange Type	Type of Lighting				\$0
2						\$0
3						\$0
Miscellaneous						Cost
1	Location/Description					
2						

Lighting Construction Subtotal \$3,778,171

**CONSTRUCTION TOTAL \$6,989,479**

*District factor will be applied when the total cost is passed to the const-1 worksheet*

PROJECT COMMENTS

Prepared by: CMS

Date Prepared/Modified: 05/05/16

Version 6.00

# BRIDGE CONSTRUCTION AND PRELIMINARY ENGINEERING COSTS

BRIDGE  
CONSTRUCTION

BRIDGE  
P. E.

Bridge Job #

Federal Structure ID

Manual CEI Cost Override :

Bridge # 1 CEI Cost :

17%

Manual PE Cost Adjustment :

Bridge #1 CN + CEI Cost :

P.E. Bridge # 1

BRIDGE #1 CN Cost : (input from Bridge PCES worksheet)

Comments - Constr. Engr. Br. #1:

Comments - Misc. P.E. Bridge #1:

Bridge Job #

Federal Structure ID

Manual CEI Cost Override :

Bridge # 2 CEI Cost :

17.0%

Manual PE Cost Adjustment :

Bridge #2 CN + CEI Cost :

P.E. Bridge # 2

BRIDGE #2 CN Cost : (input from Bridge PCES worksheet)

Comments - Constr. Engr. Br. #2:

Comments - Misc. P.E. Bridge #2:

Bridge Job #

Federal Structure ID

Manual CEI Cost Override :

Bridge # 3 CEI Cost :   
16.0%

Manual PE Cost Adjustment :

BRIDGE #3 CN Cost : (input from Bridge PCES worksheet)

Bridge #3 CN + CEI Cost :

P.E. Bridge # 3

Comments - Constr. Engr. Br. #3:

Comments - Misc. P.E. Bridge #3:

BRIDGE CONSTRUCTION AND PE COSTS (continued)

**BRIDGE  
CONSTRUCTION**

**BRIDGE  
P. E.**

Bridge Job #

Federal Structure ID

Manual CEI Cost Override :

Bridge # 4 CEI Cost :

16.0%

Manual PE Cost Adjustment :

Bridge #4 CN + CEI Cost :

P.E. Bridge # 4

BRIDGE #4 CN Cost : (input from Bridge PCES worksheet)

Comments - Constr. Engr. Br. #4:

Comments - Misc. P.E. Bridge #4:

Bridge Job #

Federal Structure ID

Manual CEI Cost Override :

Bridge # 5 CEI Cost :

16.0%

Manual PE Cost Adjustment :

Bridge #5 CN + CEI Cost :

P.E. Bridge # 5

BRIDGE #5 CN Cost : (input from Bridge PCES worksheet)

Comments - Constr. Engr. Br. #5:

Comments - Misc. P.E. Bridge #5:

Bridge Job #

Federal Structure ID

Manual CEI Cost Override :

Bridge # 6 CEI Cost :

16.0%

Manual PE Cost Adjustment :

BRIDGE #6 CN Cost : (input from Bridge PCES worksheet)

Bridge #6 CN + CEI Cost :

P.E. Bridge # 6

Comments - Constr. Engr. Br. #6:

Comments - Misc. P.E. Bridge #6:

BRIDGE CONSTRUCTION AND PE COSTS (continued)

BRIDGE  
CONSTRUCTION

BRIDGE  
P. E.

Bridge Job #

Federal Structure ID

Manual CEI Cost Override :

Bridge # 7 CEI Cost :

16.0%

Manual PE Cost Adjustment :

Bridge #7 CN + CEI Cost :

P.E. Bridge # 7

BRIDGE #7 CN Cost : (input from Bridge PCES worksheet)

Comments - Constr. Engr. Br. #7:

Comments - Misc. P.E. Bridge #7:

Bridge Job #

Federal Structure ID

Manual CEI Cost Override :

Bridge # 8 CEI Cost :

16.0%

Manual PE Cost Adjustment :

Bridge #8 CN + CEI Cost :

P.E. Bridge # 8

BRIDGE #8 CN Cost : (input from Bridge PCES worksheet)

Comments - Constr. Engr. Br. #8:

Comments - Misc. P.E. Bridge #8:

Bridge Job #

Federal Structure ID

Manual CEI Cost Override :



Bridge # 9 CEI Cost :

**\$1,415,150**

11.0%

Manual PE Cost Adjustment :

BRIDGE #9 CN Cost : (input from Bridge PCES worksheet)

**\$12,865,000**

Bridge #9 CN + CEI Cost :

**\$14,280,150**

P.E. Bridge # 9

**\$525,797**

Comments - Constr. Engr. Br. #9:

Comments - Misc. P.E. Bridge #9:

BRIDGE CONSTRUCTION AND PE COSTS (continued)

BRIDGE CONSTRUCTION

BRIDGE P. E.

Bridge Job #

[Yellow box]

Federal Structure ID

20873

Manual CEI Cost Override :

[Yellow box]

Bridge # 10 CEI Cost :

\$1,469,820

11.0%

Manual PE Cost Adjustment :

[Yellow box]

Bridge #10 CN + CEI Cost :

\$14,831,820

P.E. Bridge # 10

\$541,428

BRIDGE #10 CN Cost : (input from Bridge PCES worksheet)

\$13,362,000

Comments - Constr. Engr. Br. #10:

[White box]

Comments - Misc. P.E. Bridge #10:

[White box]

Bridge Job #

[Yellow box]

Federal Structure ID

20923

Manual CEI Cost Override :

[Yellow box]

Bridge # 11 CEI Cost :

\$165,920

16.0%

Manual PE Cost Adjustment :

[Yellow box]

Bridge #11 CN + CEI Cost :

\$1,202,920

P.E. Bridge # 11

\$153,807

BRIDGE #11 CN Cost : (input from Bridge PCES worksheet)

\$1,037,000

Comments - Constr. Engr. Br. #11:

[White box]

Comments - Misc. P.E. Bridge #11:

[White box]

Bridge Job #

[Yellow box]

Federal Structure ID

20925, 20919, 20921, 20915

Manual CEI Cost Override :

\$705,440

Bridge # 12 CEI Cost : **\$705,440**  
12.0%

Manual PE Cost Adjustment : **\$363,580**

BRIDGE #12 CN Cost : (input from Bridge PCES worksheet) **\$4,409,000**

Bridge #12 CN + CEI Cost : **\$5,114,440**

P.E. Bridge # 12 **\$623,436**

Comments - Constr. Engr. Br. #12:

Comments - Misc. P.E. Bridge #12:

Total for bridge #12 is a total of four separate bridges due to lack of space to input individually. The CEI cost and PE cost were computed for each

BRIDGE CONSTRUCTION AND PE COSTS (continued)

**BRIDGE  
CONSTRUCTION**

**BRIDGE  
P. E.**

Bridge Job #

[Yellow Box]

Federal Structure ID

20917, 20927, 20928

**Manual CEI Cost Override :**

\$2,256,090

Bridge # 13 CEI Cost : \$2,256,090

11.0%

**Manual PE Cost Adjustment :**

\$242,386

Bridge #13 CN + CEI Cost :

P.E. Bridge # 13

BRIDGE #13 CN Cost : (input from Bridge PCES worksheet) \$19,984,000

\$22,240,090

\$992,076

Comments - Constr. Engr. Br. #13:

[Empty Box]

Comments - Misc. P.E. Bridge #13:

Total for bridge #13 is a total of three separate bridges due to lack of space to input individually. The CEI cost and PE cost were computed for each

Bridge Job #

[Yellow Box]

Federal Structure ID

100, 101, 20913, 20914

**Manual CEI Cost Override :**

[Yellow Box]

Bridge # 14 CEI Cost : \$31,062,460

11.0%

**Manual PE Cost Adjustment :**

\$363,580

Bridge #14 CN + CEI Cost :

P.E. Bridge # 14

BRIDGE #14 CN Cost : (input from Bridge PCES worksheet) \$282,386,000

\$313,448,460

\$9,365,813

Comments - Constr. Engr. Br. #14:

[Empty Box]

Comments - Misc. P.E. Bridge #14:

Total for bridge #14 is a total of four separate bridges due to lack of space to input individually. The CEI cost and PE cost were computed for each

Bridge Job #

[Yellow Box]

Federal Structure ID

20353, 20352, 20339, 20355

**Manual CEI Cost Override :**

Bridge # 15 CEI Cost :

**\$15,939,330**  
*11.0%*

Manual PE Cost Adjustment :

**\$363,579**

BRIDGE #15 CN Cost : (input from Bridge PCES worksheet)

**\$144,903,000**

Bridge #15 CN + CEI Cost :

**\$160,842,330**

P.E. Bridge # 15

**\$5,041,971**



Comments - Constr. Engr. Br. #15:

Comments - Misc. P.E. Bridge #15:

Total for bridge #15 is a total of four separate bridges due to lack of space to input individually. The CEI cost and PE cost were computed for each

BRIDGE CONSTRUCTION AND PE COSTS (continued)			
		<i>Bridge Construction Base (PCES)</i>	\$488,516,000
<i>Bike / PED Construction Cost</i>	\$0		
<i>Bike / PED CE</i>	\$0	<i>Bridge Removal</i>	\$0
<i>Bike / PED PE</i>	\$0	<i>Bridge CE (PCES)</i>	\$54,564,610
<b>NOTE : Structure Complexity is based upon Height,</b>		<b>Bridge Estimate. (2016)</b>	<b>\$543,080,610</b>
<b>Difficulty of Construction, and other Factors</b>		<b>Total Bridge P. E. Costs (PCES)</b>	<b>\$18,514,848</b>

Version 6.00

 <b>Project Cost Estimating System</b> <b>COMMENTS</b> 		
<b>General / Miscellaneous Comments from CONST, RW, &amp; UTILITY Worksheets</b>	<b>Team Member and Section</b>	<b>Date Entered</b>
<b>1</b> Project terrain changed from rolling to level based on comments from L&D on draft cost estimate	C. Sutkowski - HRCS Team	06/23/16
<b>2</b> Moved 10% of roadway and structures costs for general utility relocation from CONST-MISC sheet to MANUAL sheet	C. Sutkowski - HRCS Team	06/27/16
<b>3</b> Input revised bridge costs based on comments from S&B on draft cost estimate	C. Sutkowski - HRCS Team	06/28/16
<b>4</b> Included costs for noise barriers in segment estimate as provided by noise team	C. Sutkowski - HRCS Team	06/29/16
<b>5</b> Updated costs for right-of-way with contingency added in line item in MANUAL sheet	C. Sutkowski - HRCS Team	06/29/16
<b>6</b> Added costs for right-of-way for stormwater management in MANUAL sheet	C. Sutkowski - HRCS Team	06/29/16
<b>7</b>		
<b>8</b>		
<b>9</b>		
<b>10</b>		
<b>11</b>		
<b>12</b>		
<b>13</b>		
<b>14</b>		
<b>15</b>		

**VDOT Project Cost Estimating System  
MANUAL ESTIMATE**

	DATE	PE	RW	CN
<b>EXPENDITURES</b>	01/20/16	\$839,552		\$0
<b>RUMS</b>	01/28/16			\$0
<b>TRNS*PORT</b>				\$0
<b>AWARD</b>	01/28/16			\$0
<b>PROJECTION</b>	01/28/16			\$0

**ESTIMATE YEAR**

**AD YEAR**

FY2016		FY2016
\$0	PE	\$0
\$64,352,205	RW	\$64,352,205
\$0	CN	\$0
\$64,352,205	<b>TOTAL</b>	\$64,352,205

Job #	Phase	Comment	Estimate
	RW	10% of roadway and structures costs for general utility relocation	\$56,022,396
	RW	Cost for utility work under RW project. See file Utilities Cost Estimate All Segments(AWP).xls	\$391,030
	RW	Cost for Right-of-Way. See file HRCS ROW Costs.xlsx	\$6,907,607
	RW	Cost for Right-of-Way for Stormwater Management. See file HRCS ROW Costs.xlsx	\$1,031,172

Job #	Phase	Comment	Estimate
-------	-------	---------	----------





## Project Cost Estimating System SUMMARY PAGE

<b>DISTRICT</b>	<b>HAMPTON ROADS</b>		
<b>PROJECT NUMBER</b>	<b>64965081</b>		
<b>CONSTRUCTION END YEAR</b>	<b>FY2016</b>	<b>UPC</b>	<b>106724</b>
<b>AD YEAR</b>	<b>FY2016</b>	<small>RATE OF INFLATION TO AD</small>	<b>N/A</b>
<b>ESTIMATE YEAR</b>	<b>FY2016</b>	<small>INFLATION RATE DURING CN</small>	<b>N/A</b>
<small>Date of previous estimate</small>	01/28/16		
<b>PROJECT MANAGER / DESIGNER</b>	<b>Scott.Smizik</b>		
<b>Preliminary Engineering Estimate:</b>	<b>PCES</b>		
<b>Construction Estimate:</b>	<b>PCES</b>		
<b>Right-of-Way Estimate:</b>	<b>MANUAL</b>		
<b>Utilities Estimate:</b>	<b>MANUAL</b>		
<b>DATE</b>	<b>6/30/2016</b>		

THE FOLLOWING DATA WILL BE PROVIDED UPON COMPLETION OF THE REMAINDER OF THE WORKBOOK, WHICH IS ACCESSED BY SELECTING THE CONST, RW, & UTIL TABS BELOW

<b>CONSTRUCTION ESTIMATE</b>	<b>\$2,317,457,349</b>
<b>PRELIMINARY ENGINEERING ESTIMATE</b>	<b>\$212,732,318</b>
<b>RIGHT-OF-WAY &amp; UTILITIES ESTIMATE</b>	<b>\$29,974,800</b>
<b>TOTAL PROJECT ESTIMATE</b>	<b>\$2,560,164,467</b>

Project Cost Estimating System  
CONSTRUCTION / BRIDGE / PE

Project No. **64965081**

Interstate Project ?

Route Number   **Interstate Highway**

	CONST-1	CONST-2	Bridges (0)	Total
Geometric Standard	GS-5			
Construction Base	\$2,048,326,079	\$0	\$11,669,000	\$2,059,995,079
Bridge Removal			\$0	\$0
CE	\$256,040,760		\$1,421,510	\$257,462,270
Construction Estimate (2016)	\$2,304,366,839		\$13,090,510	\$2,317,457,349
To AdYear Inflation				\$0
Mid-point construction Inflation				\$0
Total Construction Estimate			\$13,090,510	<b>\$2,317,457,349</b>
Preliminary Engineering Cost	\$212,001,749		\$730,569	\$212,732,318

### CONSTRUCTION & PE TOTALS

**Total Construction Estimate** **\$2,317,457,349** PCES  
 (Roadway plus Bridge)

**Total Preliminary Engineering Estimate** **\$212,732,318** PCES  
 (Roadway plus Bridge)

Project Cost Estimating System

CONSTRUCTION / BRIDGE / PE

Project No. **64965081**

Interstate Project ?	<input type="text" value="Yes"/>	*									
Maintenance Project ?	<input type="text" value="No"/>	*									
Route Number	<input type="text" value="564C"/>	*	Interstate Highway								
Select INTERSTATE >	<input type="text" value="GS-5"/>	*	Principal Arterial - Freeway								
Ad Date	<input type="text" value="2016"/>		Design Year = 2038								
Design Year ADT	<input type="text" value="43,200"/>	*	Project Terrain <input type="text" value="Level"/>								
<i>Box Must Be Empty</i>	<input type="text"/>		Approx. DHV = 6,480								
Enter Design Speed (MPH) (Enter 60 or 70)	<input type="text" value="70"/>	*	Minimum Design Speed = 70 MPH								
<i>Box Must Be Empty</i>	<input type="text"/>										
<i>Box Must Be Empty</i>	<input type="text"/>										
Project Length (mi.)	<input type="text" value="2.43"/>	*	<table border="0" style="width: 100%; font-size: small;"> <tr> <td style="text-align: center;"><i>Number of Additional Lanes:</i></td> <td style="text-align: center;"><i>Length of Add'l. Lanes (mi.):</i></td> </tr> <tr> <td style="text-align: center;"><input type="text" value="+ One Add'l. Lane"/></td> <td style="text-align: center;"><input type="text" value="0.61"/></td> </tr> <tr> <td style="text-align: center;"><input type="text" value="None"/></td> <td style="text-align: center;"><input type="text"/></td> </tr> <tr> <td style="text-align: center;"><input type="text" value="+ One Add'l. Lane"/></td> <td style="text-align: center;"><input type="text" value="0.27"/></td> </tr> </table>	<i>Number of Additional Lanes:</i>	<i>Length of Add'l. Lanes (mi.):</i>	<input type="text" value="+ One Add'l. Lane"/>	<input type="text" value="0.61"/>	<input type="text" value="None"/>	<input type="text"/>	<input type="text" value="+ One Add'l. Lane"/>	<input type="text" value="0.27"/>
<i>Number of Additional Lanes:</i>	<i>Length of Add'l. Lanes (mi.):</i>										
<input type="text" value="+ One Add'l. Lane"/>	<input type="text" value="0.61"/>										
<input type="text" value="None"/>	<input type="text"/>										
<input type="text" value="+ One Add'l. Lane"/>	<input type="text" value="0.27"/>										
Total Length - Adding or Building <u>Two Lanes</u> (mi.)	<input type="text"/>	*									
Total Length - Adding or Building <u>Four Lanes</u> (mi.)	<input type="text" value="0.72"/>	*									
Total Length - Building <u>Ramps and Loops</u> (mi.)	<input type="text" value="0.73"/>	*									
Shoulder or Curb & Gutter ? (Select S or C&G)	<input type="text" value="S"/>	*	Enter Lane Width (ft) > <input type="text"/>								
Median Type - Graded, Raised, or None ?	<input type="text" value="G"/>	*	Normal Lane Width(ft) <input type="text" value="12"/>								
Number of Crossovers (Divided Highways ONLY)	<input type="text"/>	*									
Length - Curb & Gutter - Left PLUS Right Side (ft.)	<input type="text"/>										
Length - Sidewalk - Left PLUS Right Side (ft.)	<input type="text"/>										
Bike / Pedestrian Type	<input type="text" value="None"/>										
Total Length - Raised Median (ft.)	<input type="text"/>										
Number of <u>Right Turn Lanes</u> - Left PLUS Right Side	<input type="text"/>	*									
Number of Left Turn Lanes - (Undivided Only)	<input type="text"/>	*									

**HAMPTON ROADS**  
 110% Cost Factor used

<b>Construction Costs</b>	
Base #1 (PCES)	<input type="text" value="\$2,048,326,079"/>
Base #2	<input type="text" value="\$0"/>
Enter Const CE Cost >	<input type="text" value="\$0"/>
CE (12.5%)	<input type="text" value="\$256,040,760"/>
Estimate (2016)	<input type="text" value="\$2,304,366,839"/>

Signals, ITS, Signs and Lighting Costs*	<input type="text" value="\$6,673,955"/>
Cost of Large Drainage Structures	<input type="text" value="\$0"/>
In-Plan Utility Costs*	<input type="text" value="\$0"/>
Adjustment for Unusual Construction Costs	<input type="text" value="\$2,026,868,926"/>

\* Totals include district factor calculations

Additional (or Unusual) P. E. Costs	<input type="text"/>	
Select % of PE to be performed by Consultants	<input type="text" value="30%"/>	PE Cost (PCES) <input type="text" value="\$212,001,749"/>

**Note: Do Not Include Bridge P. E. Costs Here**

Roadway P. E. / Roadway Const. = 9.2%

© Virginia Department of Transportation 2005  
Revised 01/21/16

**Today's Date: 06/30/16**

**Version 6.00**

<b>Project Cost Estimating System</b> Miscellaneous Cost Estimates		
<b>COST OF LARGE DRAINAGE STRUCTURES</b>		
Job#	Description	Cost ()
<input type="text"/>	<input type="text"/>	<input type="text"/>
<input type="text"/>	<input type="text"/>	<input type="text"/>
<input type="text"/>	<input type="text"/>	<input type="text"/>
<input type="text"/>	<input type="text"/>	<input type="text"/>
<input type="text"/>	<input type="text"/>	<input type="text"/>
		<b>\$0</b>
<b>ADJUSTMENT FOR UNUSUAL CONSTRUCTION COSTS</b>		
Type	Description	Cost ()
Maintenance of Traffic	20% of roadway costs for MOT	\$4,501,224
Other	5% of roadway and structures costs for landscaping	\$1,708,756
Other	Resurfacing existing roadways	\$571,167
Other	Excessive excavation	\$0
Other	Excessive borrow	\$0
Other	Concrete barrier	\$798,648
Other	Guardrail and end treatments	\$821,140
Other	Removal of existing guardrail	\$16,274
Other	Demolition of existing pavement	\$48,849
Other	Noise barriers	\$2,759,496
Other	Retaining walls	\$0
Other	Tunnel costs	\$1,427,700,000
Other	Major in-plan utility work (water and sanitary sewer)	\$0
Other	Wet ponds and bioretention facilities	\$1,700,000
Environmental	Wetland and stream impacts	\$7,350
Environmental	Historic and archaeological resources	\$1,000,000
		<input type="text"/>
		<input type="text"/>
Other	40% contingency added to base construction cost	\$585,236,023
		<b>\$2,026,868,926</b>

Version 6.00

**SIGNALS, ITS, SIGNS and LIGHTING COST WORKSHEET**

Stand Alone Traffic Project:  No

UPC: 106724

SIGNALS		New/Mod.	Intersection Type	Major				Cross				Poles	Detection	Pre-emption	Cost
Permanent Signals				Direction	Lanes	Direction	Lanes	Direction	Lanes	Direction	Lanes				
Location/Description															
1	SPUI at Naval Gate	New	Special	North	3	South	3	West	2	East	2	Comb. M.A. Lighting	Loop	No	\$208,270
2															\$0
3															\$0
4															\$0
5															\$0
6															\$0
7															\$0
8															\$0
9															\$0
10															\$0

	Quantity	Cost
Temporary Signals - New Equipment		\$0
Temporary Signals - Modified Equipment		\$0

MISCELLANEOUS SIGNAL WORK	Location/Description	Cost
1		
2		

Signals Construction Subtotal \$208,270

ITS	Location/Description	Cost
ITS WORK	1	
	2	

ITS Construction Subtotal \$0

MAJOR SIGN STRUCTURES		Quantity	Unit	Lighted Y/N	Included in Roadway Lighting? yes/no	Cost/Sign	Extended Cost
1	O/H Span (101-200)	2	Ea.	Yes		203,066	\$406,133
2	O/H Span (50-100)	12	Ea.	Yes		114,319	\$1,371,824
3			Ea.				
4			Ea.				
5			Ea.				
6			Ea.				
7			Ea.				

MISCELLANEOUS SIGN WORK	Location/Description	Cost
1	Add mile post markers at \$1,000/mile for 1.45 miles	\$1,450
2	Guide signs at SPUI interchange	\$2,688,125

Signs Construction Subtotal \$4,467,532

LIGHTING		No. Lanes	Number of Miles	Cost
<b>Continuous Roadway</b>				
1	Urban Type of Lighting			\$0
1	Freeway Type of Lighting	4	1.45	\$727,054
<b>Interchange</b>				
1	Diamond		1	\$664,376
2				\$0
3				\$0
<b>Miscellaneous</b>				
1	Location/Description			
2				

Lighting Construction Subtotal \$1,391,430

**CONSTRUCTION TOTAL \$6,067,232**

*District factor will be applied when the total cost is passed to the const-1 worksheet*

PROJECT COMMENTS

Prepared by: CMS

Date Prepared/Modified: 05/05/16

Version 6.00

# BRIDGE CONSTRUCTION AND PRELIMINARY ENGINEERING COSTS

BRIDGE  
CONSTRUCTION

BRIDGE  
P. E.

Bridge Job #

Federal Structure ID

Manual CEI Cost Override :

Bridge # 1 CEI Cost :

11%

Manual PE Cost Adjustment :

Bridge #1 CN + CEI Cost :

P.E. Bridge # 1

BRIDGE #1 CN Cost : (input from Bridge PCES worksheet)

Comments - Constr. Engr. Br. #1:

Comments - Misc. P.E. Bridge #1:

Bridge Job #

Federal Structure ID

Manual CEI Cost Override :

Bridge # 2 CEI Cost :

15.0%

Manual PE Cost Adjustment :

Bridge #2 CN + CEI Cost :

P.E. Bridge # 2

BRIDGE #2 CN Cost : (input from Bridge PCES worksheet)

Comments - Constr. Engr. Br. #2:

Comments - Misc. P.E. Bridge #2:

Bridge Job #

Federal Structure ID

Manual CEI Cost Override :

Bridge # 3 CEI Cost :   
15.0%

Manual PE Cost Adjustment :

BRIDGE #3 CN Cost : (input from Bridge PCES worksheet)

Bridge #3 CN + CEI Cost :

P.E. Bridge # 3



Comments - Constr. Engr. Br. #3:

Comments - Misc. P.E. Bridge #3:



BRIDGE CONSTRUCTION AND PE COSTS (continued)			
		<i>Bridge Construction Base (PCES)</i>	\$11,669,000
<i>Bike / PED Construction Cost</i>	\$0		
<i>Bike / PED CE</i>	\$0	<i>Bridge Removal</i>	\$0
<i>Bike / PED PE</i>	\$0	<i>Bridge CE (PCES)</i>	\$1,421,510
<b>NOTE : Structure Complexity is based upon Height,</b>		<b>Bridge Estimate. (2016)</b>	<b>\$13,090,510</b>
<b>Difficulty of Construction, and other Factors</b>		<b>Total Bridge P. E. Costs (PCES)</b>	<b>\$730,569</b>

Version 6.00

 Project Cost Estimating System <b>COMMENTS</b> 		
<b>General / Miscellaneous Comments from CONST, RW, &amp; UTILITY Worksheets</b>	<b>Team Member and Section</b>	<b>Date Entered</b>
<b>1</b> Project terrain changed from rolling to level based on comments from L&D on draft cost estimate	C. Sutkowski - HRCS Team	06/23/16
<b>2</b> Moved 10% of roadway and structures costs for general utility relocation from CONST-MISC sheet to MANUAL sheet	C. Sutkowski - HRCS Team	06/27/16
<b>3</b> Input revised bridge costs based on comments from S&B on draft cost estimate	C. Sutkowski - HRCS Team	06/28/16
<b>4</b> Included costs for noise barriers in segment estimate as provided by noise team	C. Sutkowski - HRCS Team	06/29/16
<b>5</b> Updated costs for right-of-way with contingency added in line item in MANUAL sheet	C. Sutkowski - HRCS Team	06/29/16
<b>6</b> Added costs for right-of-way for stormwater management in MANUAL sheet	C. Sutkowski - HRCS Team	06/29/16
<b>7</b>		
<b>8</b>		
<b>9</b>		
<b>10</b>		
<b>11</b>		
<b>12</b>		
<b>13</b>		
<b>14</b>		
<b>15</b>		

**VDOT Project Cost Estimating System  
MANUAL ESTIMATE**

	DATE	PE	RW	CN
<b>EXPENDITURES</b>	01/20/16	\$839,552		\$0
<b>RUMS</b>	01/28/16			\$0
<b>TRNS*PORT</b>				\$0
<b>AWARD</b>	01/28/16			\$0
<b>PROJECTION</b>	01/28/16			\$0

**ESTIMATE YEAR**

**AD YEAR**

FY2016		FY2016
\$0	<b>PE</b>	\$0
\$29,974,800	<b>RW</b>	\$29,974,800
\$0	<b>CN</b>	\$0
\$29,974,800	<b>TOTAL</b>	\$29,974,800

Job #	Phase	Comment	Estimate
	RW	10% of roadway and structures costs for general utility relocation	\$3,417,512
	RW	Cost for utility work under RW project. See file Utilities Cost Estimate All Segments(AWP).xls	\$242,100
	RW	Cost for Right-of-Way. See file HRCS ROW Costs.xlsx	\$25,860,747
	RW	Cost for Right-of-Way for Stormwater Management. See file HRCS ROW Costs.xlsx	\$454,441

Job #	Phase	Comment	Estimate
-------	-------	---------	----------



# Project Cost Estimating System

## SUMMARY PAGE

DISTRICT	<b>HAMPTON ROADS</b>		
PROJECT NUMBER	<b>64965081</b>		
CONSTRUCTION END YEAR	<b>FY2016</b>	UPC	<b>106724</b>
AD YEAR	<b>FY2016</b>	RATE OF INFLATION TO AD	<b>N/A</b>
ESTIMATE YEAR	<b>FY2016</b>	INFLATION RATE DURING CN	<b>N/A</b>
Date of previous estimate	01/28/16		
PROJECT MANAGER / DESIGNER	<b>Scott.Smizik</b>		
Preliminary Engineering Estimate:	<b>PCES</b>		
Construction Estimate:	<b>PCES</b>		
Right-of-Way Estimate:	<b>MANUAL</b>		
Utilities Estimate:	<b>MANUAL</b>		
DATE	<b>6/30/2016</b>		

THE FOLLOWING DATA WILL BE PROVIDED UPON COMPLETION OF THE REMAINDER OF THE WORKBOOK, WHICH IS ACCESSED BY SELECTING THE CONST, RW, & UTIL TABS BELOW

CONSTRUCTION ESTIMATE	<b>\$4,015,591,421</b>
PRELIMINARY ENGINEERING ESTIMATE	<b>\$367,398,736</b>
RIGHT-OF-WAY & UTILITIES ESTIMATE	<b>\$49,979,087</b>
TOTAL PROJECT ESTIMATE	<b>\$4,432,969,244</b>

© Virginia Department of Transportation 2005

Revised 01/21/16

Estimate Class: Blank

Version 6.00

Project Cost Estimating System  
CONSTRUCTION / BRIDGE / PE

Project No. **64965081**

Interstate Project ?

Route Number   **Interstate Highway**

	CONST-1	CONST-2	Bridges (0)	Total
Geometric Standard	GS-5			
Construction Base	\$3,532,575,281	\$0	\$37,241,000	\$3,569,816,281
Bridge Removal			\$0	\$0
CE	\$441,571,910		\$4,203,230	\$445,775,140
Construction Estimate (2016)	\$3,974,147,191		\$41,444,230	\$4,015,591,421
To AdYear Inflation				\$0
Mid-point construction Inflation				\$0
Total Construction Estimate			\$41,444,230	\$4,015,591,421
Preliminary Engineering Cost	\$365,621,542		\$1,777,194	\$367,398,736

### CONSTRUCTION & PE TOTALS

**Total Construction Estimate** **\$4,015,591,421** **PCES**  
 (Roadway plus Bridge)

**Total Preliminary Engineering Estimate** **\$367,398,736** **PCES**  
 (Roadway plus Bridge)



Project Cost Estimating System  
CONSTRUCTION / BRIDGE / PE



Project No. **64965081**

Interstate Project ?  \*

Maintenance Project ?  \*

Route Number  \*

Interstate Highway

Select INTERSTATE >  \*

Principal Arterial - Freeway

Ad Date

Design Year = 2038

Design Year ADT  \*

Project Terrain

*Box Must Be Empty*

Approx. DHV = 6,720  
Minimum

Enter Design Speed (MPH) (Enter 60 or 70)  \*

Design Speed = 70 MPH

*Box Must Be Empty*

*Box Must Be Empty*

Project Length (mi.)  \*

*Number of Additional Lanes:*      *Length of Add'l. Lanes (mi.):*

Total Length - Adding or Building Two Lanes (mi.)  \*

Total Length - Adding or Building Four Lanes (mi.)  \*

Total Length - Building Ramps and Loops (mi.)  \*

Shoulder or Curb & Gutter ? (Select S or C&G)  \*

Enter Lane Width (ft) >

Median Type - Graded, Raised, or None ?  \*

Normal Lane Width(ft)

Number of Crossovers (Divided Highways ONLY)

Length - Curb & Gutter - Left PLUS Right Side (ft.)

Length - Sidewalk - Left PLUS Right Side (ft.)

Bike / Pedestrian Type

Total Length - Raised Median (ft.)

Number of Right Turn Lanes - Left PLUS Right Side  \*

Number of Left Turn Lanes - (Undivided Only)  \*

HAMPTON ROADS

110% Cost Factor used

Construction Costs

Signals, ITS, Signs and Lighting Costs\*

Base #1 (PCES)

Cost of Large Drainage Structures

Base #2

In-Plan Utility Costs\*

Enter Const CE Cost >

Adjustment for Unusual Construction Costs

CE (12.5%)

\* Totals include district factor calculations

Estimate (2016)

Additional (or Unusual) P. E. Costs

Select % of PE to be performed by Consultants

PE Cost (PCES)



**Note: Do Not Include Bridge P. E. Costs Here**

Roadway P. E. / Roadway Const. = 9.2%

© Virginia Department of Transportation 2005  
Revised 01/21/16

**Today's Date: 06/30/16**

**Version 6.00**

**Project Cost Estimating System**  
**Miscellaneous Cost Estimates**

**COST OF LARGE DRAINAGE STRUCTURES**

Job#	Description	Cost ()
<input type="text"/>	<input type="text"/>	<input type="text"/>
<input type="text"/>	<input type="text"/>	<input type="text"/>
<input type="text"/>	<input type="text"/>	<input type="text"/>
<input type="text"/>	<input type="text"/>	<input type="text"/>
<input type="text"/>	<input type="text"/>	<input type="text"/>
		<b>\$0</b>

**ADJUSTMENT FOR UNUSUAL CONSTRUCTION COSTS**

Type	Description	Cost ()
Maintenance of Traffic	20% of roadway costs for MOT	\$12,038,134
Other	5% of roadway and structures costs for landscaping	\$4,871,584
Other	Resurfacing existing roadways	\$1,940,082
Other	Excessive excavation	\$0
Other	Excessive borrow	\$0
Other	Concrete barrier	\$2,650,097
Other	Guardrail and end treatments	\$2,008,119
Other	Removal of existing guardrail	\$63,754
Other	Demolition of existing pavement	\$445,636
Other	Noise barriers	\$3,100,155
Other	Retaining walls	\$12,187,407
Other	Tunnel costs	\$2,437,000,000
Other	Major in-plan utility work (water and sanitary sewer)	\$0
Other	Wet ponds and bioretention facilities	\$5,200,000
Environmental	Wetland and stream impacts	\$67,550
Environmental	Historic and archaeological resources	\$1,000,000
		<input type="text"/>
		<input type="text"/>
Other	40% contingency added to base construction cost	\$1,009,307,223
		<b>\$3,491,879,742</b>

Version 6.00



**SIGNALS, ITS, SIGNS and LIGHTING COST WORKSHEET**

Stand Alone Traffic Project:  No

UPC: 106724

**SIGNALS**

Permanent Signals	New/Mod.	Intersection Type	Major				Cross				Poles	Detection	Pre-emption	Cost	
			Direction	Lanes	Direction	Lanes	Direction	Lanes	Direction	Lanes					
Location/Description															
1	SPIU at Naval Gate	New	Special	North	3	South	3	West	2	East	2	Comb. M.A. Lighting	Loop	No	\$208,270
2															\$0
3															\$0
4															\$0
5															\$0
6															\$0
7															\$0
8															\$0
9															\$0
10															\$0

	Quantity	Cost
Temporary Signals - New Equipment		\$0
Temporary Signals - Modified Equipment		\$0

MISCELLANEOUS SIGNAL WORK	Location/Description	Cost
1		
2		

Signals Construction Subtotal \$208,270

**ITS**

ITS WORK	Location/Description	Cost
1		
2		

ITS Construction Subtotal \$0

**MAJOR SIGN STRUCTURES**

Type of Sign	Comment	Quantity	Unit	Lighted Y/N	Included in Roadway Lighting? yes/no	Cost/Sign	Extended Cost
1 O/H Span (101-200)	Signs at ends of tunnel	2	Ea.	Yes		203,066	\$406,133
2 O/H Span (50-100)	Every 1,300 feet both sides	16	Ea.	Yes		114,319	\$1,829,098
3 O/H Span (50-100)	Existing I-564	4	Ea.	No		112,819	\$451,275
4 O/H Span (50-100)	Existing I-564	1	Ea.	Yes		114,319	\$114,319
5 O/H Span (101-200)	Existing I-564	1	Ea.	Yes		203,066	\$203,066
6 Cantilever	Existing I-564	6	Ea.	No		56,409	\$338,456
7							

MISCELLANEOUS SIGN WORK	Location/Description	Cost
1	Add mile post markers at \$1,000/mile for 2.59 miles	\$2,590
2	Guide signs at SPIU interchange	\$2,688,125

Signs Construction Subtotal \$6,033,062

**LIGHTING**

Continuous Roadway		No. Lanes	Number of Miles	Cost
Urban Type of Lighting	Comments			\$0
1				
Freeway Type of Lighting	Comments			
1	Conventional	6	2.59	\$1,428,535
Interchange		Type of Lighting	Number of Interchanges	Cost
1	Diamond	Conventional	1	\$664,376
2				\$0
3				\$0
Miscellaneous		Location/Description	Cost	
1				
2				

Lighting Construction Subtotal \$2,092,911

**CONSTRUCTION TOTAL \$8,334,244**

*District factor will be applied when the total cost is passed to the const-1 worksheet*

**PROJECT COMMENTS**

Prepared by: CMS

Date Prepared/Modified: 05/05/16

Version 6.00

# BRIDGE CONSTRUCTION AND PRELIMINARY ENGINEERING COSTS

BRIDGE  
CONSTRUCTION

BRIDGE  
P. E.

Bridge Job #

Federal Structure ID

Manual CEI Cost Override :

Bridge # 1 CEI Cost :

11%

Manual PE Cost Adjustment :

Bridge #1 CN + CEI Cost :

P.E. Bridge # 1

BRIDGE #1 CN Cost : (input from Bridge PCES worksheet)

Comments - Constr. Engr. Br. #1:

Comments - Misc. P.E. Bridge #1:

Bridge Job #

Federal Structure ID

Manual CEI Cost Override :

Bridge # 2 CEI Cost :

11.0%

Manual PE Cost Adjustment :

Bridge #2 CN + CEI Cost :

P.E. Bridge # 2

BRIDGE #2 CN Cost : (input from Bridge PCES worksheet)

Comments - Constr. Engr. Br. #2:

Comments - Misc. P.E. Bridge #2:

Bridge Job #

Federal Structure ID

Manual CEI Cost Override :

Bridge # 3 CEI Cost :   
16.0%

Manual PE Cost Adjustment :

BRIDGE #3 CN Cost : (input from Bridge PCES worksheet)

Bridge #3 CN + CEI Cost :

P.E. Bridge # 3

Comments - Constr. Engr. Br. #3:

Comments - Misc. P.E. Bridge #3:

BRIDGE CONSTRUCTION AND PE COSTS (continued)

BRIDGE CONSTRUCTION

BRIDGE P. E.

Bridge Job #

[Yellow input field]

Federal Structure ID

[Yellow input field with value 13]

Manual CEI Cost Override :

[Yellow input field]

Bridge # 4 CEI Cost : \$143,140  
17.0%

Manual PE Cost Adjustment :

[Yellow input field]

BRIDGE #4 CN Cost : (input from Bridge PCES worksheet) \$842,000

Bridge #4 CN + CEI Cost :

[Blue input field with value \$985,140]

P.E. Bridge # 4

[Blue input field with value \$147,674]

Comments - Constr. Engr. Br. #4:

[White input field]

Comments - Misc. P.E. Bridge #4:

[White input field]

Bridge Job #

[Yellow input field]

Federal Structure ID

[Yellow input field with value 14]

Manual CEI Cost Override :

[Yellow input field]

Bridge # 5 CEI Cost : \$1,421,310  
11.0%

Manual PE Cost Adjustment :

[Yellow input field]

BRIDGE #5 CN Cost : (input from Bridge PCES worksheet) \$12,921,000

Bridge #5 CN + CEI Cost :

[Blue input field with value \$14,342,310]

P.E. Bridge # 5

[Blue input field with value \$527,558]

Comments - Constr. Engr. Br. #5:

[White input field]

Comments - Misc. P.E. Bridge #5:

[White input field]

Bridge Job #



[Yellow input field]

Federal Structure ID

[Yellow input field]

Manual CEI Cost Override :

BRIDGE CONSTRUCTION AND PE COSTS (continued)			
		<i>Bridge Construction Base (PCES)</i>	\$37,241,000
<i>Bike / PED Construction Cost</i>	\$0		
<i>Bike / PED CE</i>	\$0	<i>Bridge Removal</i>	\$0
<i>Bike / PED PE</i>	\$0	<i>Bridge CE (PCES)</i>	\$4,203,230
<b>NOTE : Structure Complexity is based upon Height,</b>		<b>Bridge Estimate. (2016)</b>	<b>\$41,444,230</b>
<b>Difficulty of Construction, and other Factors</b>		<b>Total Bridge P. E. Costs (PCES)</b>	<b>\$1,777,194</b>
			<b>Version 6.00</b>

 Project Cost Estimating System <b>COMMENTS</b> 		
<b>General / Miscellaneous Comments from CONST, RW, &amp; UTILITY Worksheets</b>	<b>Team Member and Section</b>	<b>Date Entered</b>
<b>1</b> Project terrain changed from rolling to level based on comments from L&D on draft cost estimate	C. Sutkowski - HRCS Team	06/23/16
<b>2</b> Moved 10% of roadway and structures costs for general utility relocation from CONST-MISC sheet to MANUAL sheet	C. Sutkowski - HRCS Team	06/27/16
<b>3</b> Input revised bridge costs based on comments from S&B on draft cost estimate	C. Sutkowski - HRCS Team	06/28/16
<b>4</b> Included costs for noise barriers in segment estimate as provided by noise team	C. Sutkowski - HRCS Team	06/29/16
<b>5</b> Updated costs for right-of-way with contingency added in line item in MANUAL sheet	C. Sutkowski - HRCS Team	06/29/16
<b>6</b> Added costs for right-of-way for stormwater management in MANUAL sheet	C. Sutkowski - HRCS Team	06/29/16
<b>7</b>		
<b>8</b>		
<b>9</b>		
<b>10</b>		
<b>11</b>		
<b>12</b>		
<b>13</b>		
<b>14</b>		
<b>15</b>		

**VDOT Project Cost Estimating System  
MANUAL ESTIMATE**

	DATE	PE	RW	CN
<b>EXPENDITURES</b>	01/20/16	\$839,552		\$0
<b>RUMS</b>	01/28/16			\$0
<b>TRNS*PORT</b>				\$0
<b>AWARD</b>	01/28/16			\$0
<b>PROJECTION</b>	01/28/16			\$0

**ESTIMATE YEAR**

**AD YEAR**

FY2016		FY2016
\$0	PE	\$0
\$49,979,087	RW	\$49,979,087
\$0	CN	\$0
\$49,979,087	<b>TOTAL</b>	\$49,979,087

Job #	Phase	Comment	Estimate
	RW	10% of roadway and structures costs for general utility relocation	\$9,743,167
	RW	Cost for utility work under RW project. See file Utilities Cost Estimate All Segments(AWP).xls	\$242,100
	RW	Cost for Right-of-Way. See file HRCS ROW Costs.xlsx	\$38,390,416
	RW	Cost for Right-of-Way for Stormwater Management. See file HRCS ROW Costs.xlsx	\$1,603,404

Job #	Phase	Comment	Estimate
-------	-------	---------	----------



# Project Cost Estimating System

## SUMMARY PAGE

DISTRICT	<b>HAMPTON ROADS</b>		
PROJECT NUMBER	<b>64965081</b>		
CONSTRUCTION END YEAR	<b>FY2016</b>	UPC	<b>106724</b>
AD YEAR	<b>FY2016</b>	RATE OF INFLATION TO AD	<b>N/A</b>
ESTIMATE YEAR	<b>FY2016</b>	INFLATION RATE DURING CN	<b>N/A</b>
Date of previous estimate	01/28/16		
PROJECT MANAGER / DESIGNER	<b>Scott.Smizik</b>		
Preliminary Engineering Estimate:	<b>PCES</b>		
Construction Estimate:	<b>PCES</b>		
Right-of-Way Estimate:	<b>MANUAL</b>		
Utilities Estimate:	<b>MANUAL</b>		
DATE	<b>6/30/2016</b>		

THE FOLLOWING DATA WILL BE PROVIDED UPON COMPLETION OF THE REMAINDER OF THE WORKBOOK, WHICH IS ACCESSED BY SELECTING THE CONST, RW, & UTIL TABS BELOW

CONSTRUCTION ESTIMATE	<b>\$1,339,225,237</b>
PRELIMINARY ENGINEERING ESTIMATE	<b>\$40,244,145</b>
RIGHT-OF-WAY & UTILITIES ESTIMATE	<b>\$119,761,800</b>
TOTAL PROJECT ESTIMATE	<b>\$1,499,231,182</b>

© Virginia Department of Transportation 2005

Revised 01/21/16

Estimate Class: Blank

Version 6.00



Project Cost Estimating System  
CONSTRUCTION / BRIDGE / PE

Project No. **64965081**

Interstate Project ?

Route Number   **Interstate Highway**

	CONST-1	CONST-2	Bridges (0)	Total
Geometric Standard	GS-5			
Construction Base	\$9,297,580	\$0	\$1,197,086,000	\$1,206,383,580
Bridge Removal			\$0	\$0
CE	\$1,162,197		\$131,679,460	\$132,841,657
Construction Estimate (2016)	\$10,459,777		\$1,328,765,460	\$1,339,225,237
To AdYear Inflation				\$0
Mid-point construction Inflation				\$0
Total Construction Estimate			\$1,328,765,460	<b>\$1,339,225,237</b>
Preliminary Engineering Cost	\$1,141,475		\$39,102,671	\$40,244,145

### CONSTRUCTION & PE TOTALS

**Total Construction Estimate** **\$1,339,225,237** **PCES**  
 (Roadway plus Bridge)

**Total Preliminary Engineering Estimate** **\$40,244,145** **PCES**  
 (Roadway plus Bridge)

Project Cost Estimating System

CONSTRUCTION / BRIDGE / PE

Project No. **64965081**

Interstate Project ?	<input type="text" value="Yes"/>	*	
Maintenance Project ?	<input type="text" value="No"/>	*	
Route Number	<input type="text" value="664C"/>	*	Interstate Highway
Select INTERSTATE >	<input type="text" value="GS-5"/>	*	Principal Arterial - Freeway
Ad Date	<input type="text" value="2016"/>		Design Year = 2038
Design Year ADT	<input type="text" value="64,400"/>	*	Project Terrain <input type="text" value="Level"/>
<i>Box Must Be Empty</i>	<input type="text"/>		Approx. DHV = 9,660
Enter Design Speed (MPH) (Enter 60 or 70)	<input type="text" value="70"/>	*	Minimum Design Speed = 70 MPH
<i>Box Must Be Empty</i>	<input type="text"/>		
<i>Box Must Be Empty</i>	<input type="text"/>		
Project Length (mi.)	<input type="text" value="4.22"/>	*	
<b>Total Length - Adding or Building Two Lanes (mi.)</b>	<input type="text"/>	*	<b>Number of Additional Lanes:</b> <input type="text"/>
<b>Total Length - Adding or Building Four Lanes (mi.)</b>	<input type="text"/>	*	<b>Length of Add'l. Lanes (mi.):</b> <input type="text"/>
<b>Total Length - Building Ramps and Loops (mi.)</b>	<input type="text"/>	*	<input type="text" value="None"/>
Shoulder or Curb & Gutter ? (Select S or C&G)	<input type="text"/>	*	Enter Lane Width (ft) > <input type="text"/>
Median Type - Graded, Raised, or None ?	<input type="text"/>	*	Normal Lane Width(ft) <input type="text" value="12"/>
Number of Crossovers (Divided Highways ONLY)	<input type="text"/>	*	
Length - Curb & Gutter - Left PLUS Right Side (ft.)	<input type="text"/>		
Length - Sidewalk - Left PLUS Right Side (ft.)	<input type="text"/>		
<b>Bike / Pedestrian Type</b>	<input type="text" value="None"/>		
Total Length - Raised Median (ft.)	<input type="text"/>		
Number of <u>Right Turn Lanes</u> - Left PLUS Right Side	<input type="text"/>	*	
Number of Left Turn Lanes - (Undivided Only)	<input type="text"/>	*	

HAMPTON ROADS

110% Cost Factor used

Construction Costs	
Base #1 (PCES)	\$9,297,580
Base #2	\$0
Enter Const CE Cost >	\$0
CE (12.5%)	\$1,162,197
Estimate (2016)	\$10,459,777

Signals, ITS, Signs and Lighting Costs*	\$6,082,528
Cost of Large Drainage Structures	\$0
In-Plan Utility Costs*	\$0
Adjustment for Unusual Construction Costs	\$3,215,051

*\* Totals include district factor calculations*

Additional (or Unusual) P. E. Costs	<input type="text"/>	
Select % of PE to be performed by Consultants	<input type="text" value="30%"/>	PE Cost (PCES) <input style="background-color: blue; color: white;" type="text" value="\$1,141,475"/>



**Note: Do Not Include Bridge P. E. Costs Here**

Roadway P. E. / Roadway Const. = 10.9%

© Virginia Department of Transportation 2005  
Revised 01/21/16

**Today's Date: 06/30/16**

**Version 6.00**

	<b>Project Cost Estimating System</b> Miscellaneous Cost Estimates	
---	---	---

**COST OF LARGE DRAINAGE STRUCTURES**

Job#	Description	Cost ()
		<b>\$0</b>

**ADJUSTMENT FOR UNUSUAL CONSTRUCTION COSTS**

Type	Description	Cost ()
Maintenance of Traffic	5% of roadway costs for MOT	\$26,600
Other	Eliminated costs for landscaping	\$0
Other	Resurfacing existing roadways	\$0
Other	Excessive excavation	\$0
Other	Excessive borrow	\$0
Other	Concrete barrier	\$32,000
Other	Guardrail and end treatments	\$0
Other	Removal of existing guardrail	\$0
Other	Demolition of existing pavement	\$0
Other	Noise barriers	\$0
Other	Retaining walls	\$0
Other	Tunnel costs	\$0
Other	Major in-plan utility work (water and sanitary sewer)	\$0
Other	Wet ponds and bioretention facilities	\$0
Environmental	Wetland and stream impacts	\$0
Environmental	Historic and archaeological resources	\$500,000
Other	40% contingency added to base construction cost	\$2,656,451
		<b>\$3,215,051</b>

Version 6.00

**SIGNALS, ITS, SIGNS and LIGHTING COST WORKSHEET**

Stand Alone Traffic Project:  No

UPC: 106724

**SIGNALS**

Permanent Signals	New/Mod.	Intersection Type	Major				Cross				Poles	Detection	Pre-emption	Cost
			Direction	Lanes	Direction	Lanes	Direction	Lanes	Direction	Lanes				
Location/Description														
1														\$0
2														\$0
3														\$0
4														\$0
5														\$0
6														\$0
7														\$0
8														\$0
9														\$0
10														\$0

Temporary Signals - New Equipment	Quantity	Cost
Temporary Signals - Modified Equipment		\$0

MISCELLANEOUS SIGNAL WORK	Location/Description	Cost
1		
2		

Signals Construction Subtotal \$0

**ITS**

ITS WORK	Location/Description	Cost
1		
2		

ITS Construction Subtotal \$0

**MAJOR SIGN STRUCTURES**

Type of Sign	Comment	Quantity	Unit	Lighted Y/N	Included in Roadway Lighting? yes/no	Cost/Sign	Extended Cost
1 O/H Span (101-200)	Every 1,300 feet both sides	8	Ea.	Yes		203,066	\$1,624,532
2			Ea.				
3			Ea.				
4			Ea.				
5			Ea.				
6			Ea.				
7			Ea.				

MISCELLANEOUS SIGN WORK	Location/Description	Cost
1	Add mile post markers at \$1,000/mile for 0.98 miles	\$980
2	Guide signs at 4-leg interchange	\$2,688,125

Signs Construction Subtotal \$4,313,637

**LIGHTING**

Continuous Roadway		Urban Type of Lighting	Comments	No. Lanes	Number of Miles	Cost
1						\$0
Freeway		Freeway Type of Lighting	Comments	No. Lanes	Number of Miles	Cost
1		Conventional		6	1.00	\$551,558
Interchange		Interchange Type	Type of Lighting		Number of Interchanges	Cost
1		Diamond	Conventional		1	\$664,376
2						\$0
3						\$0
Miscellaneous		Location/Description				Cost
1						
2						

Lighting Construction Subtotal \$1,215,934

**CONSTRUCTION TOTAL \$5,529,571**

*District factor will be applied when the total cost is passed to the const-1 worksheet*

**PROJECT COMMENTS**

Prepared by: CMS

Date Prepared/Modified: 05/05/16

Version 6.00

# BRIDGE CONSTRUCTION AND PRELIMINARY ENGINEERING COSTS

BRIDGE  
CONSTRUCTION

BRIDGE  
P. E.

Bridge Job #

Federal Structure ID

Manual CEI Cost Override :

Bridge # 1 CEI Cost :

11%

Manual PE Cost Adjustment :

Bridge #1 CN + CEI Cost :

P.E. Bridge # 1

BRIDGE #1 CN Cost : (input from Bridge PCES worksheet)

Comments - Constr. Engr. Br. #1:

Comments - Misc. P.E. Bridge #1:

Bridge Job #

Federal Structure ID

Manual CEI Cost Override :

Bridge # 2 CEI Cost :

11.0%

Manual PE Cost Adjustment :

Bridge #2 CN + CEI Cost :

P.E. Bridge # 2

BRIDGE #2 CN Cost : (input from Bridge PCES worksheet)

Comments - Constr. Engr. Br. #2:

Comments - Misc. P.E. Bridge #2:

Bridge Job #

Federal Structure ID

Manual CEI Cost Override :

Bridge # 3 CEI Cost : \$3,640,010  
*11.0%*

Manual PE Cost Adjustment :

BRIDGE #3 CN Cost : (input from Bridge PCES worksheet) \$33,091,000

Bridge #3 CN + CEI Cost : \$36,731,010

P.E. Bridge # 3  
\$1,161,905

Comments - Constr. Engr. Br. #3:

Comments - Misc. P.E. Bridge #3:

BRIDGE CONSTRUCTION AND PE COSTS (continued)

**BRIDGE  
CONSTRUCTION**

**BRIDGE  
P. E.**

Bridge Job #

Federal Structure ID

Manual CEI Cost Override :

Bridge # 4 CEI Cost : **\$10,395,330**

11.0%

Manual PE Cost Adjustment :

Bridge #4 CN + CEI Cost :

P.E. Bridge # 4

BRIDGE #4 CN Cost : (input from Bridge PCES worksheet) **\$94,503,000**

Comments - Constr. Engr. Br. #4:

Comments - Misc. P.E. Bridge #4:

Bridge Job #

Federal Structure ID

Manual CEI Cost Override :

Bridge # 5 CEI Cost : **\$5,183,200**

11.0%

Manual PE Cost Adjustment :

Bridge #5 CN + CEI Cost :

P.E. Bridge # 5

BRIDGE #5 CN Cost : (input from Bridge PCES worksheet) **\$47,120,000**

Comments - Constr. Engr. Br. #5:

Comments - Misc. P.E. Bridge #5:

Bridge Job #

Federal Structure ID

Manual CEI Cost Override :



Bridge # 6 CEI Cost :

\$7,974,780  
11.0%

Manual PE Cost Adjustment :

BRIDGE #6 CN Cost : (input from Bridge PCES worksheet)

\$72,498,000

Bridge #6 CN + CEI Cost :

\$80,472,780

P.E. Bridge # 6

\$2,401,255

Comments - Constr. Engr. Br. #6:

Comments - Misc. P.E. Bridge #6:

BRIDGE CONSTRUCTION AND PE COSTS (continued)

BRIDGE CONSTRUCTION

BRIDGE P. E.

Bridge Job #

[Yellow box]

Federal Structure ID

119

Manual CEI Cost Override :

[Yellow box]

Bridge # 7 CEI Cost : \$6,137,780

11.0%

Manual PE Cost Adjustment :

[Yellow box]

Bridge #7 CN + CEI Cost :

\$61,935,780

P.E. Bridge # 7

\$1,876,040

BRIDGE #7 CN Cost : (input from Bridge PCES worksheet) \$55,798,000

Comments - Constr. Engr. Br. #7:

[White box]

Comments - Misc. P.E. Bridge #7:

[White box]

Bridge Job #

[Yellow box]

Federal Structure ID

120

Manual CEI Cost Override :

[Yellow box]

Bridge # 8 CEI Cost : \$5,611,870

11.0%

Manual PE Cost Adjustment :

[Yellow box]

Bridge #8 CN + CEI Cost :

\$56,628,870

P.E. Bridge # 8

\$1,725,678

BRIDGE #8 CN Cost : (input from Bridge PCES worksheet) \$51,017,000

Comments - Constr. Engr. Br. #8:

[White box]

Comments - Misc. P.E. Bridge #8:

[White box]

Bridge Job #

[Yellow box]

Federal Structure ID

121

Manual CEI Cost Override :

Bridge # 9 CEI Cost :

11.0%

Manual PE Cost Adjustment :

BRIDGE #9 CN Cost : (input from Bridge PCES worksheet)

Bridge #9 CN + CEI Cost :

P.E. Bridge # 9

Comments - Constr. Engr. Br. #9:

Comments - Misc. P.E. Bridge #9:

BRIDGE CONSTRUCTION AND PE COSTS (continued)

BRIDGE CONSTRUCTION

BRIDGE P. E.

Bridge Job #

[Yellow box]

Federal Structure ID

122

Manual CEI Cost Override :

[Yellow box]

Bridge # 10 CEI Cost :

\$6,127,880

11.0%

Manual PE Cost Adjustment :

[Yellow box]

Bridge #10 CN + CEI Cost :

P.E. Bridge # 10

BRIDGE #10 CN Cost : (input from Bridge PCES worksheet)

\$55,708,000

\$61,835,880

\$1,873,210

Comments - Constr. Engr. Br. #10:

[White box]

Comments - Misc. P.E. Bridge #10:

[White box]

Bridge Job #

[Yellow box]

Federal Structure ID

123

Manual CEI Cost Override :

[Yellow box]

Bridge # 11 CEI Cost :

\$6,912,070

11.0%

Manual PE Cost Adjustment :

[Yellow box]

Bridge #11 CN + CEI Cost :

P.E. Bridge # 11

BRIDGE #11 CN Cost : (input from Bridge PCES worksheet)

\$62,837,000

\$69,749,070

\$2,097,417

Comments - Constr. Engr. Br. #11:

[White box]

Comments - Misc. P.E. Bridge #11:

[White box]

Bridge Job #

[Yellow box]

Federal Structure ID

132

Manual CEI Cost Override :

[Yellow box]

Bridge # 12 CEI Cost : \$48,152,720  
11.0%

Manual PE Cost Adjustment :

BRIDGE #12 CN Cost : (input from Bridge PCES worksheet) \$437,752,000



Bridge #12 CN + CEI Cost : \$485,904,720

P.E. Bridge # 12 \$13,888,493

Comments - Constr. Engr. Br. #12:

Comments - Misc. P.E. Bridge #12:

BRIDGE CONSTRUCTION AND PE COSTS (continued)			
		<i>Bridge Construction Base (PCES)</i>	\$1,197,086,000
<i>Bike / PED Construction Cost</i>	\$0		
<i>Bike / PED CE</i>	\$0	<i>Bridge Removal</i>	\$0
<i>Bike / PED PE</i>	\$0	<i>Bridge CE (PCES)</i>	\$131,679,460
<b>NOTE : Structure Complexity is based upon Height,</b>		<b>Bridge Estimate. (2016)</b>	<b>\$1,328,765,460</b>
<b>Difficulty of Construction, and other Factors</b>		<b>Total Bridge P. E. Costs (PCES)</b>	<b>\$39,102,671</b>
			<b>Version 6.00</b>

 Project Cost Estimating System <b>COMMENTS</b> 		
<b>General / Miscellaneous Comments from CONST, RW, &amp; UTILITY Worksheets</b>	<b>Team Member and Section</b>	<b>Date Entered</b>
<b>1</b> Project terrain changed from rolling to level based on comments from L&D on draft cost estimate	C. Sutkowski - HRCS Team	06/23/16
<b>2</b> Moved 10% of roadway and structures costs for general utility relocation from CONST-MISC sheet to MANUAL sheet	C. Sutkowski - HRCS Team	06/27/16
<b>3</b> Input revised bridge costs based on comments from S&B on draft cost estimate	C. Sutkowski - HRCS Team	06/28/16
<b>4</b> Included costs for noise barriers in segment estimate as provided by noise team	C. Sutkowski - HRCS Team	06/29/16
<b>5</b>		
<b>6</b>		
<b>7</b>		
<b>8</b>		
<b>9</b>		
<b>10</b>		
<b>11</b>		
<b>12</b>		
<b>13</b>		
<b>14</b>		
<b>15</b>		

UPC: 106724

**VDOT Project Cost Estimating System  
MANUAL ESTIMATE**

	DATE	PE	RW	CN
EXPENDITURES	01/20/16	\$839,552		\$0
RUMS	01/28/16			\$0
TRNS*PORT				\$0
AWARD	01/28/16			\$0
PROJECTION	01/28/16			\$0

**ESTIMATE YEAR**

**AD YEAR**

FY2016		FY2016
\$0	PE	\$0
\$119,761,800	RW	\$119,761,800
\$0	CN	\$0
\$119,761,800	<b>TOTAL</b>	\$119,761,800

Job #	Phase	Comment	Estimate
	RW	10% of roadway and structures costs for general utility relocation	\$119,761,800
	RW	Cost for utility work under RW project. See file Utilities Cost Estimate All Segments(AWP).xls	\$0
	RW	Cost for Right-of-Way. See file HRCS ROW Costs.xlsx	\$0
	RW	Cost for Right-of-Way for Stormwater Management. See file HRCS ROW Costs.xlsx	\$0

Job #	Phase	Comment	Estimate
-------	-------	---------	----------





# Project Cost Estimating System

## SUMMARY PAGE

DISTRICT	<b>HAMPTON ROADS</b>		
PROJECT NUMBER	<b>64965081</b>		
CONSTRUCTION END YEAR	<b>FY2016</b>	UPC	<b>106724</b>
AD YEAR	<b>FY2016</b>	RATE OF INFLATION TO AD	<b>N/A</b>
ESTIMATE YEAR	<b>FY2016</b>	INFLATION RATE DURING CN	<b>N/A</b>
Date of previous estimate	01/28/16		
PROJECT MANAGER / DESIGNER	<b>Scott.Smizik</b>		
Preliminary Engineering Estimate:	<b>PCES</b>		
Construction Estimate:	<b>PCES</b>		
Right-of-Way Estimate:	<b>MANUAL</b>		
Utilities Estimate:	<b>MANUAL</b>		
DATE	<b>6/30/2016</b>		

THE FOLLOWING DATA WILL BE PROVIDED UPON COMPLETION OF THE REMAINDER OF THE WORKBOOK, WHICH IS ACCESSED BY SELECTING THE CONST, RW, & UTIL TABS BELOW



CONSTRUCTION ESTIMATE	<b>\$930,848,401</b>
PRELIMINARY ENGINEERING ESTIMATE	<b>\$28,324,098</b>
RIGHT-OF-WAY & UTILITIES ESTIMATE	<b>\$83,183,700</b>
TOTAL PROJECT ESTIMATE	<b>\$1,042,356,199</b>

© Virginia Department of Transportation 2005

Revised 01/21/16

Estimate Class: Blank

Version 6.00

	Project Cost Estimating System CONSTRUCTION / BRIDGE / PE	
---	--	---

Project No. **64965081**

Interstate Project ?

Route Number   **Interstate Highway**

	CONST-1	CONST-2	Bridges (0)	Total
Geometric Standard	GS-5			
Construction Base	\$7,051,494	\$0	\$831,321,000	\$838,372,494
Bridge Removal			\$0	\$0
CE	\$881,437		\$91,594,470	\$92,475,907
Construction Estimate (2016)	\$7,932,931		\$922,915,470	\$930,848,401
To AdYear Inflation				\$0
Mid-point construction Inflation				\$0
<b>Total Construction Estimate</b>			<b>\$922,915,470</b>	<b>\$930,848,401</b>
Preliminary Engineering Cost	\$967,122		\$27,356,975	\$28,324,098

### CONSTRUCTION & PE TOTALS

<b>Total Construction Estimate</b> (Roadway plus Bridge)	<div style="border: 2px solid black; padding: 5px; display: inline-block;"> <b>\$930,848,401</b> </div>	<b>PCES</b>
<b>Total Preliminary Engineering Estimate</b> (Roadway plus Bridge)	<div style="border: 2px solid black; padding: 5px; display: inline-block;"> <b>\$28,324,098</b> </div>	<b>PCES</b>

Project Cost Estimating System

CONSTRUCTION / BRIDGE / PE

Project No. **64965081**

Interstate Project ?  \*

Maintenance Project ?  \*

Route Number  \*

**Interstate Highway**

Select INTERSTATE >  \*

**Principal Arterial - Freeway**

Ad Date

Design Year =

Design Year ADT  \*

Project Terrain

*Box Must Be Empty*

Approx. DHV =   
Minimum

Enter Design Speed (MPH) (Enter 60 or 70)  \*

Design Speed =

*Box Must Be Empty*

*Box Must Be Empty*

Project Length (mi.)  \*

**Number of Additional Lanes:**  **Length of Add'l. Lanes (mi.):**

Total Length - Adding or Building **Two Lanes** (mi.)  \*

Total Length - Adding or Building **Four Lanes** (mi.)  \*

Total Length - Building **Ramps and Loops** (mi.)  \*

Shoulder or Curb & Gutter ? (Select S or C&G)  \*

Enter Lane Width (ft) >

Median Type - Graded, Raised, or None ?  \*

Normal Lane Width(ft)

Number of Crossovers (Divided Highways ONLY)  \*

Length - Curb & Gutter - Left PLUS Right Side (ft.)

Length - Sidewalk - Left PLUS Right Side (ft.)

Bike / Pedestrian Type

Total Length - Raised Median (ft.)

Number of **Right Turn Lanes** - Left PLUS Right Side  \*

Number of **Left Turn Lanes** - (Undivided Only)  \*

**HAMPTON ROADS**

**110%** Cost Factor used

**Construction Costs**

Signals, ITS, Signs and Lighting Costs\*

Base #1 (PCES)

Cost of Large Drainage Structures

Base #2

In-Plan Utility Costs\*

Enter Const CE Cost >

Adjustment for Unusual Construction Costs

CE (12.5%)

*\* Totals include district factor calculations*

Estimate (2016)

Additional (or Unusual) P. E. Costs

Select % of PE to be performed by Consultants

PE Cost (PCES)

**Note: Do Not Include Bridge P. E. Costs Here**

Roadway P. E. / Roadway Const. = 12.2%

© Virginia Department of Transportation 2005  
Revised 01/21/16

**Today's Date: 06/30/16**

**Version 6.00**

<b>Project Cost Estimating System</b> Miscellaneous Cost Estimates		
<b>COST OF LARGE DRAINAGE STRUCTURES</b>		
Job#	Description	Cost ()
<input type="text"/>	<input type="text"/>	<input type="text"/>
<input type="text"/>	<input type="text"/>	<input type="text"/>
<input type="text"/>	<input type="text"/>	<input type="text"/>
<input type="text"/>	<input type="text"/>	<input type="text"/>
<input type="text"/>	<input type="text"/>	<input type="text"/>
		<b>\$0</b>
<b>ADJUSTMENT FOR UNUSUAL CONSTRUCTION COSTS</b>		
Type	Description	Cost ()
Maintenance of Traffic	5% of roadway costs for MOT	\$25,800
Other	Eliminated costs for landscaping	\$0
Other	Resurfacing existing roadways	\$0
Other	Excessive excavation	\$0
Other	Excessive borrow	\$0
Other	Concrete barrier	\$16,000
Other	Guardrail and end treatments	\$0
Other	Removal of existing guardrail	\$0
Other	Demolition of existing pavement	\$0
Other	Noise barriers	\$0
Other	Retaining walls	\$0
Other	Tunnel costs	\$0
Other	Major in-plan utility work (water and sanitary sewer)	\$0
Other	Wet ponds and bioretention facilities	\$0
Environmental	Wetland and stream impacts	\$0
Environmental	Historic and archaeological resources	\$500,000
		<input type="text"/>
		<input type="text"/>
Other	40% contingency added to base construction cost	\$2,014,713
		<b>\$2,556,513</b>

Version 6.00

**SIGNALS, ITS, SIGNS and LIGHTING COST WORKSHEET**

Stand Alone Traffic Project:  No

UPC: 106724

**SIGNALS**

Permanent Signals	New/Mod.	Intersection Type	Major				Cross				Poles	Detection	Pre-emption	Cost
			Direction	Lanes	Direction	Lanes	Direction	Lanes	Direction	Lanes				
Location/Description														
1														\$0
2														\$0
3														\$0
4														\$0
5														\$0
6														\$0
7														\$0
8														\$0
9														\$0
10														\$0

Temporary Signals - New Equipment	Quantity	Cost
Temporary Signals - Modified Equipment		\$0

MISCELLANEOUS SIGNAL WORK	Location/Description	Cost
1		
2		
<b>Signals Construction Subtotal</b>		<b>\$0</b>

ITS	Location/Description	Cost
ITS WORK 1		
2		
<b>ITS Construction Subtotal</b>		<b>\$0</b>

MAJOR SIGN STRUCTURES	Type of Sign	Comment	Quantity	Unit	Lighted Y/N	Included in Roadway Lighting? yes/no	Cost/Sign	Extended Cost
1	O/H Span (50-100)	Every 1,300 feet both sides	8	Ea.	Yes		114,319	\$914,549
2				Ea.				
3				Ea.				
4				Ea.				
5				Ea.				
6				Ea.				
7				Ea.				
Location/Description								
MISCELLANEOUS 1	Add mile post markers at \$1,000/mile for 0.98 miles							\$980
SIGN WORK 2	Guide signs at 3-leg interchange							\$2,005,025
<b>Signs Construction Subtotal</b>								<b>\$2,920,554</b>

LIGHTING	Continuous Roadway	Interchange	Miscellaneous	Cost
Urban Type of Lighting	Comments	No. Lanes	Number of Miles	
	1			\$0
Freeway Type of Lighting	Comments	No. Lanes	Number of Miles	
	1	Conventional	4	\$501,416
Interchange	Interchange Type	Type of Lighting	Number of Interchanges	
	1	Diamond	Conventional	1
	2			\$0
3				\$0
Location/Description				Cost
1				
2				
<b>Lighting Construction Subtotal</b>				<b>\$1,165,793</b>
<b>CONSTRUCTION TOTAL</b>				<b>\$4,086,347</b>

*District factor will be applied when the total cost is passed to the const-1 worksheet*

PROJECT COMMENTS

Prepared by: CMS

Date Prepared/Modified: 05/05/16

Version 6.00

# BRIDGE CONSTRUCTION AND PRELIMINARY ENGINEERING COSTS

BRIDGE  
CONSTRUCTION

BRIDGE  
P. E.

Bridge Job #

Federal Structure ID

Manual CEI Cost Override :

Bridge # 1 CEI Cost :

14%

Manual PE Cost Adjustment :

Bridge #1 CN + CEI Cost :

P.E. Bridge # 1

BRIDGE #1 CN Cost : (input from Bridge PCES worksheet)

Comments - Constr. Engr. Br. #1:

Comments - Misc. P.E. Bridge #1:

Bridge Job #

Federal Structure ID

Manual CEI Cost Override :

Bridge # 2 CEI Cost :

14.0%

Manual PE Cost Adjustment :

Bridge #2 CN + CEI Cost :

P.E. Bridge # 2

BRIDGE #2 CN Cost : (input from Bridge PCES worksheet)

Comments - Constr. Engr. Br. #2:

Comments - Misc. P.E. Bridge #2:

Bridge Job #

Federal Structure ID

Manual CEI Cost Override :

Bridge # 3 CEI Cost : \$22,919,050  
*11.0%*

Manual PE Cost Adjustment :

BRIDGE #3 CN Cost : (input from Bridge PCES worksheet) \$208,355,000

Bridge #3 CN + CEI Cost : \$231,274,050

P.E. Bridge # 3  
\$6,673,958

Comments - Constr. Engr. Br. #3:

Comments - Misc. P.E. Bridge #3:



BRIDGE CONSTRUCTION AND PE COSTS (continued)

**BRIDGE  
CONSTRUCTION**

**BRIDGE  
P. E.**

Bridge Job #

Federal Structure ID

Manual CEI Cost Override :

Bridge # 4 CEI Cost :

11.0%

Manual PE Cost Adjustment :

Bridge #4 CN + CEI Cost :

P.E. Bridge # 4

BRIDGE #4 CN Cost : (input from Bridge PCES worksheet)

Comments - Constr. Engr. Br. #4:

Comments - Misc. P.E. Bridge #4:

Bridge Job #

Federal Structure ID

Manual CEI Cost Override :

Bridge # 5 CEI Cost :

11.0%

Manual PE Cost Adjustment :

Bridge #5 CN + CEI Cost :

P.E. Bridge # 5

BRIDGE #5 CN Cost : (input from Bridge PCES worksheet)

Comments - Constr. Engr. Br. #5:

Comments - Misc. P.E. Bridge #5:

Bridge Job #

Federal Structure ID

Manual CEI Cost Override :

Bridge # 6 CEI Cost :

\$5,637,720

11.0%

Manual PE Cost Adjustment :

BRIDGE #6 CN Cost : (input from Bridge PCES worksheet)

Bridge #6 CN + CEI Cost :

P.E. Bridge # 6

Comments - Constr. Engr. Br. #6:

Comments - Misc. P.E. Bridge #6:

BRIDGE CONSTRUCTION AND PE COSTS (continued)

BRIDGE CONSTRUCTION

BRIDGE P. E.

Bridge Job #

[Yellow box]

Federal Structure ID

128

Manual CEI Cost Override :

[Yellow box]

Bridge # 7 CEI Cost : \$5,611,870

11.0%

Manual PE Cost Adjustment :

[Yellow box]

Bridge #7 CN + CEI Cost :

\$56,628,870

P.E. Bridge # 7

\$1,725,678

BRIDGE #7 CN Cost : (input from Bridge PCES worksheet) \$51,017,000

Comments - Constr. Engr. Br. #7:

[White box]

Comments - Misc. P.E. Bridge #7:

[White box]

Bridge Job #

[Yellow box]

Federal Structure ID

129

Manual CEI Cost Override :

[Yellow box]

Bridge # 8 CEI Cost : \$3,186,370

11.0%

Manual PE Cost Adjustment :

[Yellow box]

Bridge #8 CN + CEI Cost :

\$32,153,370

P.E. Bridge # 8

\$1,032,205

BRIDGE #8 CN Cost : (input from Bridge PCES worksheet) \$28,967,000

Comments - Constr. Engr. Br. #8:

[White box]

Comments - Misc. P.E. Bridge #8:

[White box]

Bridge Job #

[Yellow box]

Federal Structure ID

130

Manual CEI Cost Override :

Bridge # 9 CEI Cost :

\$7,646,760  
11.0%

Manual PE Cost Adjustment :

BRIDGE #9 CN Cost : (input from Bridge PCES worksheet)

\$69,516,000

Bridge #9 CN + CEI Cost :

\$77,162,760

P.E. Bridge # 9

\$2,307,471

Comments - Constr. Engr. Br. #9:

Comments - Misc. P.E. Bridge #9:

BRIDGE CONSTRUCTION AND PE COSTS (continued)

BRIDGE CONSTRUCTION

BRIDGE P. E.

Bridge Job #

[Yellow input field]

Federal Structure ID

[Yellow input field with value 133]

Manual CEI Cost Override :

[Yellow input field]

Bridge # 10 CEI Cost :

[Blue input field with value \$32,101,850]

11.0%

Manual PE Cost Adjustment :

[Yellow input field]

Bridge #10 CN + CEI Cost :

[Blue input field with value \$323,936,850]

P.E. Bridge # 10

[Blue input field with value \$9,299,404]

BRIDGE #10 CN Cost : (input from Bridge PCES worksheet)

[Green input field with value \$291,835,000]

Comments - Constr. Engr. Br. #10:

[White text input field]

Comments - Misc. P.E. Bridge #10:

[White text input field]

Bridge Job #

[Yellow input field]

Federal Structure ID

[Yellow input field]

Manual CEI Cost Override :

[Yellow input field]

Bridge # 11 CEI Cost :

[Blue input field with value \$0]

18.0%

Manual PE Cost Adjustment :

[Yellow input field]

Bridge #11 CN + CEI Cost :

[Blue input field with value \$0]

P.E. Bridge # 11

[Blue input field with value \$0]

BRIDGE #11 CN Cost : (input from Bridge PCES worksheet)

[Green input field]

Comments - Constr. Engr. Br. #11:

[White text input field]

Comments - Misc. P.E. Bridge #11:

[White text input field]

Bridge Job #

[Yellow input field]

Federal Structure ID



[Yellow input field]

Manual CEI Cost Override :

[Yellow input field]

BRIDGE CONSTRUCTION AND PE COSTS (continued)			
		<i>Bridge Construction Base (PCES)</i>	\$831,321,000
<i>Bike / PED Construction Cost</i>	\$0		
<i>Bike / PED CE</i>	\$0	<i>Bridge Removal</i>	\$0
<i>Bike / PED PE</i>	\$0	<i>Bridge CE (PCES)</i>	\$91,594,470
<b>NOTE : Structure Complexity is based upon Height,</b>		<b>Bridge Estimate. (2016)</b>	<b>\$922,915,470</b>
<b>Difficulty of Construction, and other Factors</b>		<b>Total Bridge P. E. Costs (PCES)</b>	<b>\$27,356,975</b>

Version 6.00

 <b>Project Cost Estimating System</b> <b>COMMENTS</b> 		
<b>General / Miscellaneous Comments from CONST, RW, &amp; UTILITY Worksheets</b>	<b>Team Member and Section</b>	<b>Date Entered</b>
<b>1</b> Project terrain changed from rolling to level based on comments from L&D on draft cost estimate	C. Sutkowski - HRCS Team	06/23/16
<b>2</b> Moved 10% of roadway and structures costs for general utility relocation from CONST-MISC sheet to MANUAL sheet	C. Sutkowski - HRCS Team	06/27/16
<b>3</b> Input revised bridge costs based on comments from S&B on draft cost estimate	C. Sutkowski - HRCS Team	06/28/16
<b>4</b> Included costs for noise barriers in segment estimate as provided by noise team	C. Sutkowski - HRCS Team	06/29/16
<b>5</b>		
<b>6</b>		
<b>7</b>		
<b>8</b>		
<b>9</b>		
<b>10</b>		
<b>11</b>		
<b>12</b>		
<b>13</b>		
<b>14</b>		
<b>15</b>		

**VDOT Project Cost Estimating System  
MANUAL ESTIMATE**

	DATE	PE	RW	CN
<b>EXPENDITURES</b>	01/20/16	\$839,552		\$0
<b>RUMS</b>	01/28/16			\$0
<b>TRNS*PORT</b>				\$0
<b>AWARD</b>	01/28/16			\$0
<b>PROJECTION</b>	01/28/16			\$0

**ESTIMATE YEAR**

**AD YEAR**

FY2016		FY2016
\$0	PE	\$0
\$83,183,700	RW	\$83,183,700
\$0	CN	\$0
\$83,183,700	<b>TOTAL</b>	\$83,183,700

Job #	Phase	Comment	Estimate
	RW	10% of roadway and structures costs for general utility relocation	\$83,183,700
	RW	Cost for utility work under RW project. See file Utilities Cost Estimate All Segments(AWP).xls	\$0
	RW	Cost for Right-of-Way. See file HRCS ROW Costs.xlsx	\$0
	RW	Cost for Right-of-Way for Stormwater Management. See file HRCS ROW Costs.xlsx	\$0

Job #	Phase	Comment	Estimate
-------	-------	---------	----------





## Project Cost Estimating System SUMMARY PAGE

<b>DISTRICT</b>	<b>HAMPTON ROADS</b>		
<b>PROJECT NUMBER</b>	<b>64965081</b>		
<b>CONSTRUCTION END YEAR</b>	<b>FY2016</b>	<b>UPC</b>	<b>106724</b>
<b>AD YEAR</b>	<b>FY2016</b>	<small>RATE OF INFLATION TO AD</small>	<b>N/A</b>
<b>ESTIMATE YEAR</b>	<b>FY2016</b>	<small>INFLATION RATE DURING CN</small>	<b>N/A</b>

Date of previous estimate 01/28/16

**PROJECT MANAGER / DESIGNER** **Scott.Smizik**

Preliminary Engineering Estimate:	<b>PCES</b>
Construction Estimate:	<b>PCES</b>
Right-of-Way Estimate:	<b>MANUAL</b>
Utilities Estimate:	<b>MANUAL</b>

**DATE** 6/30/2016

THE FOLLOWING DATA WILL BE PROVIDED UPON COMPLETION OF THE REMAINDER OF THE WORKBOOK, WHICH IS ACCESSED BY SELECTING THE CONST, RW, & UTIL TABS BELOW

<b>CONSTRUCTION ESTIMATE</b>	<b>\$201,721,357</b>
<b>PRELIMINARY ENGINEERING ESTIMATE</b>	<b>\$6,609,239</b>
<b>RIGHT-OF-WAY &amp; UTILITIES ESTIMATE</b>	<b>\$21,101,197</b>
<b>TOTAL PROJECT ESTIMATE</b>	<b>\$229,431,793</b>

Project Cost Estimating System  
CONSTRUCTION / BRIDGE / PE

Project No. **64965081**

Interstate Project ?

Route Number   **Interstate Highway**

	CONST-1	CONST-2	Bridges (0)	Total
Geometric Standard	GS-5			
Construction Base	\$7,712,727	\$0	\$173,914,000	\$181,626,727
Bridge Removal			\$0	\$0
CE	\$964,091		\$19,130,540	\$20,094,631
Construction Estimate (2016)	\$8,676,817		\$193,044,540	\$201,721,357
To AdYear Inflation				\$0
Mid-point construction Inflation				\$0
Total Construction Estimate			\$193,044,540	<b>\$201,721,357</b>
Preliminary Engineering Cost	\$1,018,450		\$5,590,788	\$6,609,239

### CONSTRUCTION & PE TOTALS

<b>Total Construction Estimate</b>	<b>\$201,721,357</b>	<b>PCES</b>
(Roadway plus Bridge)		
<b>Total Preliminary Engineering Estimate</b>	<b>\$6,609,239</b>	<b>PCES</b>
(Roadway plus Bridge)		

Project Cost Estimating System

CONSTRUCTION / BRIDGE / PE

Project No. **64965081**

Interstate Project ?	<input type="text" value="Yes"/>	*									
Maintenance Project ?	<input type="text" value="No"/>	*									
Route Number	<input type="text" value="564C"/>	*	Interstate Highway								
Select INTERSTATE >	<input type="text" value="GS-5"/>	*	Principal Arterial - Freeway								
Ad Date	<input type="text" value="2016"/>		Design Year = 2038								
Design Year ADT	<input type="text" value="26,900"/>	*	Project Terrain <input type="text" value="Level"/>								
<i>Box Must Be Empty</i>	<input type="text"/>		Approx. DHV = 4,035								
Enter Design Speed (MPH) (Enter 60 or 70)	<input type="text" value="70"/>	*	Minimum Design Speed = 70 MPH								
<i>Box Must Be Empty</i>	<input type="text"/>										
<i>Box Must Be Empty</i>	<input type="text"/>										
Project Length (mi.)	<input type="text" value="0.94"/>	*	<table border="0" style="width: 100%; font-size: small;"> <tr> <td style="text-align: center;"><i>Number of Additional Lanes:</i></td> <td style="text-align: center;"><i>Length of Add'l. Lanes (mi.):</i></td> </tr> <tr> <td><input type="text"/></td> <td><input type="text"/></td> </tr> <tr> <td><input type="text" value="None"/></td> <td><input type="text"/></td> </tr> <tr> <td><input type="text" value="None"/></td> <td><input type="text"/></td> </tr> </table>	<i>Number of Additional Lanes:</i>	<i>Length of Add'l. Lanes (mi.):</i>	<input type="text"/>	<input type="text"/>	<input type="text" value="None"/>	<input type="text"/>	<input type="text" value="None"/>	<input type="text"/>
<i>Number of Additional Lanes:</i>	<i>Length of Add'l. Lanes (mi.):</i>										
<input type="text"/>	<input type="text"/>										
<input type="text" value="None"/>	<input type="text"/>										
<input type="text" value="None"/>	<input type="text"/>										
Total Length - Adding or Building <b>Two Lanes</b> (mi.)	<input type="text"/>	*									
Total Length - Adding or Building <b>Four Lanes</b> (mi.)	<input type="text" value="0.25"/>	*									
Total Length - Building <b>Ramps and Loops</b> (mi.)	<input type="text"/>	*									
Shoulder or Curb & Gutter ? (Select S or C&G)	<input type="text" value="S"/>	*	Enter Lane Width (ft) > <input type="text"/>								
Median Type - Graded, Raised, or None ?	<input type="text" value="N"/>	*	Normal Lane Width(ft) <input type="text" value="12"/>								
Number of Crossovers (Divided Highways ONLY)	<input type="text"/>	*									
Length - Curb & Gutter - Left PLUS Right Side (ft.)	<input type="text"/>										
Length - Sidewalk - Left PLUS Right Side (ft.)	<input type="text"/>										
Bike / Pedestrian Type	<input type="text" value="None"/>										
Total Length - Raised Median (ft.)	<input type="text"/>										
Number of <b>Right Turn Lanes</b> - Left PLUS Right Side	<input type="text"/>	*									
Number of <b>Left Turn Lanes</b> - (Undivided Only)	<input type="text"/>	*									

**HAMPTON ROADS**  
 110% Cost Factor used

<b>Construction Costs</b>	
Base #1 (PCES)	<input type="text" value="\$7,712,727"/>
Base #2	<input type="text" value="\$0"/>
Enter Const CE Cost >	<input type="text" value="\$0"/>
CE (12.5%)	<input type="text" value="\$964,091"/>
Estimate (2016)	<input type="text" value="\$8,676,817"/>

Signals, ITS, Signs and Lighting Costs*	<input type="text" value="\$1,446,084"/>
Cost of Large Drainage Structures	<input type="text" value="\$0"/>
In-Plan Utility Costs*	<input type="text" value="\$0"/>
Adjustment for Unusual Construction Costs	<input type="text" value="\$3,249,350"/>

\* Totals include district factor calculations

Additional (or Unusual) P. E. Costs	<input type="text"/>	
Select % of PE to be performed by Consultants	<input type="text" value="30%"/>	PE Cost (PCES) <input type="text" value="\$1,018,450"/>

**Note: Do Not Include Bridge P. E. Costs Here**

Roadway P. E. / Roadway Const. = 11.7%

© Virginia Department of Transportation 2005  
Revised 01/21/16

**Today's Date: 06/30/16**

**Version 6.00**

<b>Project Cost Estimating System</b> Miscellaneous Cost Estimates		
<b>COST OF LARGE DRAINAGE STRUCTURES</b>		
Job#	Description	Cost ()
<input type="text"/>	<input type="text"/>	<input type="text"/>
<input type="text"/>	<input type="text"/>	<input type="text"/>
<input type="text"/>	<input type="text"/>	<input type="text"/>
<input type="text"/>	<input type="text"/>	<input type="text"/>
<input type="text"/>	<input type="text"/>	<input type="text"/>
		<b>\$0</b>
<b>ADJUSTMENT FOR UNUSUAL CONSTRUCTION COSTS</b>		
Type	Description	Cost ()
Maintenance of Traffic	5% of roadway costs for MOT	\$193,477
Other	Eliminated costs for landscaping	\$0
Other	Resurfacing existing roadways	\$0
Other	Excessive excavation	\$0
Other	Excessive borrow	\$0
Other	Concrete barrier	\$346,010
Other	Guardrail and end treatments	\$6,227
Other	Removal of existing guardrail	\$0
Other	Demolition of existing pavement	\$0
Other	Noise barriers	\$0
Other	Retaining walls	\$0
Other	Tunnel costs	\$0
Other	Major in-plan utility work (water and sanitary sewer)	\$0
Other	Wet ponds and bioretention facilities	\$0
Environmental	Wetland and stream impacts	\$0
Environmental	Historic and archaeological resources	\$500,000
<input type="text"/>	<input type="text"/>	<input type="text"/>
<input type="text"/>	<input type="text"/>	<input type="text"/>
Other	40% contingency added to base construction cost	\$2,203,636
		<b>\$3,249,350</b>

Version 6.00

**SIGNALS, ITS, SIGNS and LIGHTING COST WORKSHEET**

Stand Alone Traffic Project:  No

UPC: 106724

**SIGNALS**

Permanent Signals	New/Mod.	Intersection Type	Major				Cross				Poles	Detection	Pre-emption	Cost
			Direction	Lanes	Direction	Lanes	Direction	Lanes	Direction	Lanes				
Location/Description														
1														\$0
2														\$0
3														\$0
4														\$0
5														\$0
6														\$0
7														\$0
8														\$0
9														\$0
10														\$0

Temporary Signals - New Equipment	Quantity	Cost
Temporary Signals - Modified Equipment		\$0

MISCELLANEOUS SIGNAL WORK	Location/Description	Cost
1		
2		
<b>Signals Construction Subtotal</b>		<b>\$0</b>

ITS	Location/Description	Cost
ITS WORK 1		
2		
<b>ITS Construction Subtotal</b>		<b>\$0</b>

MAJOR SIGN STRUCTURES	Type of Sign	Comment	Quantity	Unit	Lighted Y/N	Included in Roadway Lighting? yes/no	Cost/Sign	Extended Cost
1	O/H Span (101-200)	Every 1,300 feet	4	Ea.	Yes		203,066	\$812,266
2				Ea.				
3				Ea.				
4				Ea.				
5				Ea.				
6				Ea.				
7				Ea.				
MISCELLANEOUS 1	Location/Description							Cost
SIGN WORK 2	Add mile post markers at \$1,000/mile for 0.94 miles							\$940
<b>Signs Construction Subtotal</b>								<b>\$813,206</b>

LIGHTING	Continuous Roadway	Urban Type of Lighting	Comments	No. Lanes	Number of Miles	Cost
1						\$0
1	Freeway Type of Lighting	Conventional		4	1.00	\$501,416
1	Interchange	Interchange Type	Type of Lighting		Number of Interchanges	Cost
2						\$0
3						\$0
Miscellaneous	Location/Description					Cost
1						
2						
<b>Lighting Construction Subtotal</b>						<b>\$501,416</b>
<b>CONSTRUCTION TOTAL</b>						<b>\$1,314,622</b>

*District factor will be applied when the total cost is passed to the const-1 worksheet*

**PROJECT COMMENTS**

Prepared by: CMS

Date Prepared/Modified: 05/05/16

Version 6.00

# BRIDGE CONSTRUCTION AND PRELIMINARY ENGINEERING COSTS

BRIDGE  
CONSTRUCTION

BRIDGE  
P. E.

Bridge Job #

Federal Structure ID

Manual CEI Cost Override :

Bridge # 1 CEI Cost :

11%

Manual PE Cost Adjustment :

Bridge #1 CN + CEI Cost :

P.E. Bridge # 1

BRIDGE #1 CN Cost : (input from Bridge PCES worksheet)

Comments - Constr. Engr. Br. #1:

Comments - Misc. P.E. Bridge #1:

Bridge Job #

Federal Structure ID

Manual CEI Cost Override :

Bridge # 2 CEI Cost :

18.0%

Manual PE Cost Adjustment :

Bridge #2 CN + CEI Cost :

P.E. Bridge # 2

BRIDGE #2 CN Cost : (input from Bridge PCES worksheet)

Comments - Constr. Engr. Br. #2:



Comments - Misc. P.E. Bridge #2:

Bridge Job #

Federal Structure ID

BRIDGE CONSTRUCTION AND PE COSTS (continued)			
		<i>Bridge Construction Base (PCES)</i>	\$173,914,000
<i>Bike / PED Construction Cost</i>	\$0		
<i>Bike / PED CE</i>	\$0	<i>Bridge Removal</i>	\$0
<i>Bike / PED PE</i>	\$0	<i>Bridge CE (PCES)</i>	\$19,130,540
<b>NOTE : Structure Complexity is based upon Height,</b>		<b>Bridge Estimate. (2016)</b>	<b>\$193,044,540</b>
<b>Difficulty of Construction, and other Factors</b>		<b>Total Bridge P. E. Costs (PCES)</b>	<b>\$5,590,788</b>
			<b>Version 6.00</b>



 <b>Project Cost Estimating System</b> <b>COMMENTS</b> 		
<b>General / Miscellaneous Comments from CONST, RW, &amp; UTILITY Worksheets</b>	<b>Team Member and Section</b>	<b>Date Entered</b>
<b>1</b> Project terrain changed from rolling to level based on comments from L&D on draft cost estimate	C. Sutkowski - HRCS Team	06/23/16
<b>2</b> Moved 10% of roadway and structures costs for general utility relocation from CONST-MISC sheet to MANUAL sheet	C. Sutkowski - HRCS Team	06/27/16
<b>3</b> Input revised bridge costs based on comments from S&B on draft cost estimate	C. Sutkowski - HRCS Team	06/28/16
<b>4</b> Included costs for noise barriers in segment estimate as provided by noise team	C. Sutkowski - HRCS Team	06/29/16
<b>5</b> Updated costs for right-of-way with contingency added in line item in MANUAL sheet	C. Sutkowski - HRCS Team	06/29/16
<b>6</b>		
<b>7</b>		
<b>8</b>		
<b>9</b>		
<b>10</b>		
<b>11</b>		
<b>12</b>		
<b>13</b>		
<b>14</b>		
<b>15</b>		

UPC: 106724

**VDOT Project Cost Estimating System  
MANUAL ESTIMATE**

	DATE	PE	RW	CN
<b>EXPENDITURES</b>	01/20/16	\$839,552		\$0
<b>RUMS</b>	01/28/16			\$0
<b>TRNS*PORT</b>				\$0
<b>AWARD</b>	01/28/16			\$0
<b>PROJECTION</b>	01/28/16			\$0

**ESTIMATE YEAR**

**AD YEAR**

FY2016		FY2016
\$0	PE	\$0
\$21,101,197	RW	\$21,101,197
\$0	CN	\$0
\$21,101,197	<b>TOTAL</b>	\$21,101,197

Job #	Phase	Comment	Estimate
	RW	10% of roadway and structures costs for general utility relocation	\$17,778,353
	RW	Cost for utility work under RW project. See file Utilities Cost Estimate All Segments(AWP).xls	\$1,089,000
	RW	Cost for Right-of-Way. See file HRCS ROW Costs.xlsx	\$2,233,844
	RW	Cost for Right-of-Way for Stormwater Management. See file HRCS ROW Costs.xlsx	\$0

Job #	Phase	Comment	Estimate
-------	-------	---------	----------



## Project Cost Estimating System SUMMARY PAGE

DISTRICT	<b>HAMPTON ROADS</b>		
PROJECT NUMBER	<b>64965081</b>		
CONSTRUCTION END YEAR	<b>FY2016</b>	UPC	<b>106724</b>
AD YEAR	<b>FY2016</b>	RATE OF INFLATION TO AD	<b>N/A</b>
ESTIMATE YEAR	<b>FY2016</b>	INFLATION RATE DURING CN	<b>N/A</b>

Date of previous estimate 01/28/16

PROJECT MANAGER / DESIGNER **Scott.Smizik**

Preliminary Engineering Estimate:	<b>PCES</b>
Construction Estimate:	<b>PCES</b>
Right-of-Way Estimate:	<b>MANUAL</b>
Utilities Estimate:	<b>MANUAL</b>

DATE **6/30/2016**

THE FOLLOWING DATA WILL BE PROVIDED UPON COMPLETION OF THE REMAINDER OF THE WORKBOOK, WHICH IS ACCESSED BY SELECTING THE CONST, RW, & UTIL TABS BELOW

CONSTRUCTION ESTIMATE	<b>\$511,972,714</b>
PRELIMINARY ENGINEERING ESTIMATE	<b>\$16,210,040</b>
RIGHT-OF-WAY & UTILITIES ESTIMATE	<b>\$48,847,700</b>
TOTAL PROJECT ESTIMATE	<b>\$577,030,454</b>

Project Cost Estimating System

CONSTRUCTION / BRIDGE / PE

Project No. **64965081**

Interstate Project ?

Route Number   **Interstate Highway**

	CONST-1	CONST-2	Bridges (0)	Total
Geometric Standard	GS-5			
Construction Base	\$12,180,084	\$0	\$448,892,000	\$461,072,084
Bridge Removal			\$0	\$0
CE	\$1,522,510		\$49,378,120	\$50,900,630
Construction Estimate (2016)	\$13,702,594		\$498,270,120	\$511,972,714
To AdYear Inflation				\$0
Mid-point construction Inflation				\$0
Total Construction Estimate			\$498,270,120	<b>\$511,972,714</b>
Preliminary Engineering Cost	\$1,365,229		\$14,844,811	\$16,210,040

### CONSTRUCTION & PE TOTALS

**Total Construction Estimate** **\$511,972,714** **PCES**  
 (Roadway plus Bridge)

**Total Preliminary Engineering Estimate** **\$16,210,040** **PCES**  
 (Roadway plus Bridge)

Project Cost Estimating System

CONSTRUCTION / BRIDGE / PE

Project No. **64965081**

Interstate Project ?	<input type="text" value="Yes"/>	*									
Maintenance Project ?	<input type="text" value="No"/>	*									
Route Number	<input type="text" value="564C"/>	*	Interstate Highway								
Select INTERSTATE >	<input type="text" value="GS-5"/>	*	Principal Arterial - Freeway								
Ad Date	<input type="text" value="2016"/>		Design Year = 2038								
Design Year ADT	<input type="text" value="44,800"/>	*	Project Terrain <input type="text" value="Level"/>								
<i>Box Must Be Empty</i>	<input type="text"/>		Approx. DHV = 6,720								
Enter Design Speed (MPH) (Enter 60 or 70)	<input type="text"/>	*	Design Speed = 30 MPH								
<i>Box Must Be Empty</i>	<input type="text"/>										
<i>Box Must Be Empty</i>	<input type="text"/>										
Project Length (mi.)	<input type="text" value="1.89"/>	*	<table border="0" style="width: 100%; font-size: small;"> <tr> <td style="text-align: center;"><i>Number of Additional Lanes:</i></td> <td style="text-align: center;"><i>Length of Add'l. Lanes (mi.):</i></td> </tr> <tr> <td><input type="text"/></td> <td><input type="text"/></td> </tr> <tr> <td><input type="text" value="+ Two Add'l. Lanes"/></td> <td><input type="text" value="0.20"/></td> </tr> <tr> <td><input type="text" value="None"/></td> <td><input type="text"/></td> </tr> </table>	<i>Number of Additional Lanes:</i>	<i>Length of Add'l. Lanes (mi.):</i>	<input type="text"/>	<input type="text"/>	<input type="text" value="+ Two Add'l. Lanes"/>	<input type="text" value="0.20"/>	<input type="text" value="None"/>	<input type="text"/>
<i>Number of Additional Lanes:</i>	<i>Length of Add'l. Lanes (mi.):</i>										
<input type="text"/>	<input type="text"/>										
<input type="text" value="+ Two Add'l. Lanes"/>	<input type="text" value="0.20"/>										
<input type="text" value="None"/>	<input type="text"/>										
Total Length - Adding or Building <b>Two Lanes</b> (mi.)	<input type="text"/>	*									
Total Length - Adding or Building <b>Four Lanes</b> (mi.)	<input type="text" value="0.25"/>	*									
Total Length - Building <b>Ramps and Loops</b> (mi.)	<input type="text"/>	*									
Shoulder or Curb & Gutter ? (Select S or C&G)	<input type="text" value="S"/>	*	Enter Lane Width (ft) > <input type="text"/>								
Median Type - Graded, Raised, or None ?	<input type="text" value="N"/>	*	Normal Lane Width(ft) <input type="text" value="12"/>								
Number of Crossovers (Divided Highways ONLY)	<input type="text"/>	*									
Length - Curb & Gutter - Left PLUS Right Side (ft.)	<input type="text"/>										
Length - Sidewalk - Left PLUS Right Side (ft.)	<input type="text"/>										
Bike / Pedestrian Type	<input type="text" value="None"/>										
Total Length - Raised Median (ft.)	<input type="text"/>										
Number of <b>Right Turn Lanes</b> - Left PLUS Right Side	<input type="text"/>	*									
Number of Left Turn Lanes - (Undivided Only)	<input type="text"/>	*									

**HAMPTON ROADS**  
 110% Cost Factor used  
**Construction Costs**

Signals, ITS, Signs and Lighting Costs*	<input type="text" value="\$4,984,004"/>		Base #1 (PCES)	<input type="text" value="\$12,180,084"/>
Cost of Large Drainage Structures	<input type="text" value="\$0"/>		Base #2	<input type="text" value="\$0"/>
In-Plan Utility Costs*	<input type="text" value="\$0"/>		Enter Const CE Cost >	<input type="text" value="\$0"/>
Adjustment for Unusual Construction Costs	<input type="text" value="\$4,806,742"/>		CE (12.5%)	<input type="text" value="\$1,522,510"/>
* Totals include district factor calculations			Estimate (2016)	<input type="text" value="\$13,702,594"/>

Additional (or Unusual) P. E. Costs	<input type="text"/>	
Select % of PE to be performed by Consultants	<input type="text" value="30%"/>	PE Cost (PCES) <input type="text" value="\$1,365,229"/>



**Note: Do Not Include Bridge P. E. Costs Here**

Roadway P. E. / Roadway Const. = 10.0%

© Virginia Department of Transportation 2005  
Revised 01/21/16

**Today's Date: 06/30/16**

**Version 6.00**

**Project Cost Estimating System**  
**Miscellaneous Cost Estimates**

**COST OF LARGE DRAINAGE STRUCTURES**

Job#	Description	Cost ()
		<b>\$0</b>

**ADJUSTMENT FOR UNUSUAL CONSTRUCTION COSTS**

Type	Description	Cost ()
Maintenance of Traffic	5% of roadway costs for MOT	\$176,955
Other	Eliminated costs for landscaping	\$0
Other	Resurfacing existing roadways	\$0
Other	Excessive excavation	\$0
Other	Excessive borrow	\$0
Other	Concrete barrier	\$637,309
Other	Guardrail and end treatments	\$12,453
Other	Removal of existing guardrail	\$0
Other	Demolition of existing pavement	\$0
Other	Noise barriers	\$0
Other	Retaining walls	\$0
Other	Tunnel costs	\$0
Other	Major in-plan utility work (water and sanitary sewer)	\$0
Other	Wet ponds and bioretention facilities	\$0
Environmental	Wetland and stream impacts	\$0
Environmental	Historic and archaeological resources	\$500,000
Other	40% contingency added to base construction cost	\$3,480,024
		<b>\$4,806,742</b>

Version 6.00

**SIGNALS, ITS, SIGNS and LIGHTING COST WORKSHEET**

Stand Alone Traffic Project:  No

UPC: 106724

**SIGNALS**

Permanent Signals	New/Mod.	Intersection Type	Major				Cross				Poles	Detection	Pre-emption	Cost
			Direction	Lanes	Direction	Lanes	Direction	Lanes	Direction	Lanes				
Location/Description														
1														\$0
2														\$0
3														\$0
4														\$0
5														\$0
6														\$0
7														\$0
8														\$0
9														\$0
10														\$0

Temporary Signals - New Equipment	Quantity	Cost
Temporary Signals - Modified Equipment		\$0

MISCELLANEOUS SIGNAL WORK	Location/Description	Cost
1		
2		

Signals Construction Subtotal \$0

**ITS**

ITS WORK	Location/Description	Cost
1		
2		

ITS Construction Subtotal \$0

**MAJOR SIGN STRUCTURES**

Type of Sign	Comment	Quantity	Unit	Lighted Y/N	Included in Roadway Lighting? yes/no	Cost/Sign	Extended Cost
1 O/H Span (50-100)	Every 1,300 feet both sides	10	Ea.	Yes		114,319	\$1,143,186
2			Ea.				
3			Ea.				
4			Ea.				
5			Ea.				
6			Ea.				
7			Ea.				

MISCELLANEOUS SIGN WORK	Location/Description	Cost
1	Add mile post markers at \$1,000/mile for 1.30 miles	\$1,300
2	Guide signs at directional 3-leg interchange	\$2,005,025

Signs Construction Subtotal \$3,149,511

**LIGHTING**

Continuous Roadway		Urban Type of Lighting		Comments	No. Lanes	Number of Miles	Cost
1							\$0
Freeway Type of Lighting				Comments	No. Lanes	Number of Miles	Cost
1	Conventional				6	1.30	\$717,025
Interchange		Interchange Type		Type of Lighting	Number of Interchanges		Cost
1	Diamond			Conventional	1		\$664,376
2							\$0
3							\$0
Miscellaneous		Location/Description					Cost
1							
2							

Lighting Construction Subtotal \$1,381,402

**CONSTRUCTION TOTAL \$4,530,913**

*District factor will be applied when the total cost is passed to the const-1 worksheet*

**PROJECT COMMENTS**

Prepared by: CMS

Date Prepared/Modified: 05/05/16

Version 6.00



# BRIDGE CONSTRUCTION AND PRELIMINARY ENGINEERING COSTS

BRIDGE  
CONSTRUCTION

BRIDGE  
P. E.

Bridge Job #

Federal Structure ID

Manual CEI Cost Override :

Bridge # 1 CEI Cost :

11%

Manual PE Cost Adjustment :

Bridge #1 CN + CEI Cost :

P.E. Bridge # 1

BRIDGE #1 CN Cost : (input from Bridge PCES worksheet)

Comments - Constr. Engr. Br. #1:

Comments - Misc. P.E. Bridge #1:

Bridge Job #

Federal Structure ID

Manual CEI Cost Override :

Bridge # 2 CEI Cost :

11.0%

Manual PE Cost Adjustment :

Bridge #2 CN + CEI Cost :

P.E. Bridge # 2

BRIDGE #2 CN Cost : (input from Bridge PCES worksheet)

Comments - Constr. Engr. Br. #2:

Comments - Misc. P.E. Bridge #2:

Bridge Job #

Federal Structure ID

Manual CEI Cost Override :

Bridge # 3 CEI Cost : \$5,660,710  
*11.0%*

Manual PE Cost Adjustment :

BRIDGE #3 CN Cost : (input from Bridge PCES worksheet) \$51,461,000

Bridge #3 CN + CEI Cost : \$57,121,710

P.E. Bridge # 3

\$1,739,641

Comments - Constr. Engr. Br. #3:

Comments - Misc. P.E. Bridge #3:

BRIDGE CONSTRUCTION AND PE COSTS (continued)

**BRIDGE  
CONSTRUCTION**

**BRIDGE  
P. E.**

Bridge Job #

Federal Structure ID

Manual CEI Cost Override :

Bridge # 4 CEI Cost : **\$2,035,440**

11.0%

Manual PE Cost Adjustment :

Bridge #4 CN + CEI Cost :

P.E. Bridge # 4

BRIDGE #4 CN Cost : (input from Bridge PCES worksheet) **\$18,504,000**

Comments - Constr. Engr. Br. #4:

Comments - Misc. P.E. Bridge #4:

Bridge Job #

Federal Structure ID

Manual CEI Cost Override :

Bridge # 5 CEI Cost : **\$7,321,820**

11.0%

Manual PE Cost Adjustment :

Bridge #5 CN + CEI Cost :

P.E. Bridge # 5

BRIDGE #5 CN Cost : (input from Bridge PCES worksheet) **\$66,562,000**

Comments - Constr. Engr. Br. #5:

Comments - Misc. P.E. Bridge #5:

Bridge Job #

Federal Structure ID

Manual CEI Cost Override :

Bridge # 6 CEI Cost :

**\$6,193,550**

11.0%

Manual PE Cost Adjustment :

BRIDGE #6 CN Cost : (input from Bridge PCES worksheet)

**\$56,305,000**

Bridge #6 CN + CEI Cost :

**\$62,498,550**



P.E. Bridge # 6

**\$1,891,985**

Comments - Constr. Engr. Br. #6:

Comments - Misc. P.E. Bridge #6:

BRIDGE CONSTRUCTION AND PE COSTS (continued)			
		<i>Bridge Construction Base (PCES)</i>	\$448,892,000
<i>Bike / PED Construction Cost</i>	\$0		
<i>Bike / PED CE</i>	\$0	<i>Bridge Removal</i>	\$0
<i>Bike / PED PE</i>	\$0	<i>Bridge CE (PCES)</i>	\$49,378,120
<b>NOTE : Structure Complexity is based upon Height,</b>		<b>Bridge Estimate. (2016)</b>	<b>\$498,270,120</b>
<b>Difficulty of Construction, and other Factors</b>		<b>Total Bridge P. E. Costs (PCES)</b>	<b>\$14,844,811</b>
			<b>Version 6.00</b>

 Project Cost Estimating System <b>COMMENTS</b> 		
<b>General / Miscellaneous Comments from CONST, RW, &amp; UTILITY Worksheets</b>	<b>Team Member and Section</b>	<b>Date Entered</b>
<b>1</b> Project terrain changed from rolling to level based on comments from L&D on draft cost estimate	C. Sutkowski - HRCS Team	06/23/16
<b>2</b> Moved 10% of roadway and structures costs for general utility relocation from CONST-MISC sheet to MANUAL sheet	C. Sutkowski - HRCS Team	06/27/16
<b>3</b> Input revised bridge costs based on comments from S&B on draft cost estimate	C. Sutkowski - HRCS Team	06/28/16
<b>4</b> Included costs for noise barriers in segment estimate as provided by noise team	C. Sutkowski - HRCS Team	06/29/16
<b>5</b> Updated costs for right-of-way with contingency added in line item in MANUAL sheet	C. Sutkowski - HRCS Team	06/29/16
<b>6</b>		
<b>7</b>		
<b>8</b>		
<b>9</b>		
<b>10</b>		
<b>11</b>		
<b>12</b>		
<b>13</b>		
<b>14</b>		
<b>15</b>		

UPC: 106724

**VDOT Project Cost Estimating System  
MANUAL ESTIMATE**

	DATE	PE	RW	CN
<b>EXPENDITURES</b>	01/20/16	\$839,552		\$0
<b>RUMS</b>	01/28/16			\$0
<b>TRNS*PORT</b>				\$0
<b>AWARD</b>	01/28/16			\$0
<b>PROJECTION</b>	01/28/16			\$0

**ESTIMATE YEAR**

**AD YEAR**

FY2016		FY2016
\$0	PE	\$0
\$48,847,700	RW	\$48,847,700
\$0	CN	\$0
\$48,847,700	<b>TOTAL</b>	\$48,847,700

Job #	Phase	Comment	Estimate
	RW	10% of roadway and structures costs for general utility relocation	\$45,243,110
	RW	Cost for utility work under RW project. See file Utilities Cost Estimate All Segments(AWP).xls	\$1,089,000
	RW	Cost for Right-of-Way. See file HRCS ROW Costs.xlsx	\$2,515,590
	RW	Cost for Right-of-Way for Stormwater Management. See file HRCS ROW Costs.xlsx	\$0

Job #	Phase	Comment	Estimate
-------	-------	---------	----------



## Project Cost Estimating System SUMMARY PAGE

DISTRICT	<b>HAMPTON ROADS</b>		
PROJECT NUMBER	<b>64965081</b>		
CONSTRUCTION END YEAR	<b>FY2016</b>	UPC	<b>106724</b>
AD YEAR	<b>FY2016</b>	RATE OF INFLATION TO AD	<b>N/A</b>
ESTIMATE YEAR	<b>FY2016</b>	INFLATION RATE DURING CN	<b>N/A</b>
Date of previous estimate	01/28/16		
PROJECT MANAGER / DESIGNER	<b>Scott.Smizik</b>		
Preliminary Engineering Estimate:	<b>PCES</b>		
Construction Estimate:	<b>PCES</b>		
Right-of-Way Estimate:	<b>MANUAL</b>		
Utilities Estimate:	<b>MANUAL</b>		
DATE	<b>6/30/2016</b>		

THE FOLLOWING DATA WILL BE PROVIDED UPON COMPLETION OF THE REMAINDER OF THE WORKBOOK, WHICH IS ACCESSED BY SELECTING THE CONST, RW, & UTIL TABS BELOW

CONSTRUCTION ESTIMATE	<b>\$455,805,660</b>
PRELIMINARY ENGINEERING ESTIMATE	<b>\$14,640,987</b>
RIGHT-OF-WAY & UTILITIES ESTIMATE	<b>\$43,771,448</b>
TOTAL PROJECT ESTIMATE	<b>\$514,218,095</b>



© Virginia Department of Transportation 2005

Revised 01/21/16

Estimate Class: Blank

Version 6.00



	Project Cost Estimating System CONSTRUCTION / BRIDGE / PE	
---	--	---

Project No. **64965081**

Interstate Project ?

Route Number   **Interstate Highway**

	CONST-1	CONST-2	Bridges (0)	Total
Geometric Standard	GS-5			
Construction Base	\$12,668,533	\$0	\$397,796,000	\$410,464,533
Bridge Removal			\$0	\$0
CE	\$1,583,567		\$43,757,560	\$45,341,127
Construction Estimate (2016)	\$14,252,100		\$441,553,560	\$455,805,660
To AdYear Inflation				\$0
Mid-point construction Inflation				\$0
Total Construction Estimate			\$441,553,560	<b>\$455,805,660</b>
Preliminary Engineering Cost	\$1,403,145		\$13,237,842	\$14,640,987

### CONSTRUCTION & PE TOTALS

**Total Construction Estimate** **\$455,805,660** **PCES**  
(Roadway plus Bridge)

**Total Preliminary Engineering Estimate** **\$14,640,987** **PCES**  
(Roadway plus Bridge)

Project Cost Estimating System

CONSTRUCTION / BRIDGE / PE

Project No. **64965081**

Interstate Project ?	<input type="text" value="Yes"/>	*					
Maintenance Project ?	<input type="text" value="No"/>	*					
Route Number	<input type="text" value="564C"/>	*	Interstate Highway				
Select INTERSTATE >	<input type="text" value="GS-5"/>	*	Principal Arterial - Freeway				
Ad Date	<input type="text" value="2016"/>		Design Year = 2038				
Design Year ADT	<input type="text" value="43,200"/>	*	Project Terrain <input type="text" value="Level"/>				
<i>Box Must Be Empty</i>	<input type="text"/>		Approx. DHV = 6,480				
Enter Design Speed (MPH) (Enter 60 or 70)	<input type="text" value="70"/>	*	Minimum Design Speed = 70 MPH				
<i>Box Must Be Empty</i>	<input type="text"/>						
<i>Box Must Be Empty</i>	<input type="text"/>						
Project Length (mi.)	<input type="text" value="1.89"/>	*	<table border="0" style="margin-left: auto; margin-right: auto;"> <tr> <td style="text-align: center;"><i>Number of Additional Lanes:</i></td> <td style="text-align: center;"><i>Length of Add'l. Lanes (mi.):</i></td> </tr> <tr> <td style="text-align: center;"><input type="text"/></td> <td style="text-align: center;"><input type="text"/></td> </tr> </table>	<i>Number of Additional Lanes:</i>	<i>Length of Add'l. Lanes (mi.):</i>	<input type="text"/>	<input type="text"/>
<i>Number of Additional Lanes:</i>	<i>Length of Add'l. Lanes (mi.):</i>						
<input type="text"/>	<input type="text"/>						
Total Length - Adding or Building <b>Two Lanes</b> (mi.)	<input type="text"/>	*	<input type="text"/>				
Total Length - Adding or Building <b>Four Lanes</b> (mi.)	<input type="text" value="0.25"/>	*	<input type="text" value="None"/>				
Total Length - Building <b>Ramps and Loops</b> (mi.)	<input type="text"/>	*	<input type="text" value="None"/>				
Shoulder or Curb & Gutter ? (Select S or C&G)	<input type="text" value="S"/>	*	Enter Lane Width (ft) > <input type="text"/>				
Median Type - Graded, Raised, or None ?	<input type="text" value="N"/>	*	Normal Lane Width(ft) <input type="text" value="12"/>				
Number of Crossovers (Divided Highways ONLY)	<input type="text"/>	*					
Length - Curb & Gutter - Left PLUS Right Side (ft.)	<input type="text"/>						
Length - Sidewalk - Left PLUS Right Side (ft.)	<input type="text"/>						
Bike / Pedestrian Type	<input type="text" value="None"/>						
Total Length - Raised Median (ft.)	<input type="text"/>						
Number of <b>Right Turn Lanes</b> - Left PLUS Right Side	<input type="text"/>	*					
Number of <b>Left Turn Lanes</b> - (Undivided Only)	<input type="text"/>	*					

**HAMPTON ROADS**  
 110% Cost Factor used

Construction Costs	
Base #1 (PCES)	\$12,668,533
Base #2	\$0
Enter Const CE Cost >	\$0
CE (12.5%)	\$1,583,567
Estimate (2016)	\$14,252,100

Signals, ITS, Signs and Lighting Costs*	\$4,912,302
Cost of Large Drainage Structures	\$0
In-Plan Utility Costs*	\$0
Adjustment for Unusual Construction Costs	\$4,738,939

*\* Totals include district factor calculations*

Additional (or Unusual) P. E. Costs	<input type="text"/>	
Select % of PE to be performed by Consultants	<input type="text" value="30%"/>	PE Cost (PCES) <b>\$1,403,145</b>



**Note: Do Not Include Bridge P. E. Costs Here**

Roadway P. E. / Roadway Const. = 9.8%

© Virginia Department of Transportation 2005  
Revised 01/21/16

**Today's Date: 06/30/16**

**Version 6.00**

	<b>Project Cost Estimating System</b> Miscellaneous Cost Estimates	
---	---	---

**COST OF LARGE DRAINAGE STRUCTURES**

Job#	Description	Cost ()
		<b>\$0</b>

**ADJUSTMENT FOR UNUSUAL CONSTRUCTION COSTS**

Type	Description	Cost ()
Maintenance of Traffic	5% of roadway costs for MOT	\$196,983
Other	Eliminated costs for landscaping	\$0
Other	Resurfacing existing roadways	\$0
Other	Excessive excavation	\$0
Other	Excessive borrow	\$0
Other	Concrete barrier	\$409,921
Other	Guardrail and end treatments	\$12,453
Other	Removal of existing guardrail	\$0
Other	Demolition of existing pavement	\$0
Other	Noise barriers	\$0
Other	Retaining walls	\$0
Other	Tunnel costs	\$0
Other	Major in-plan utility work (water and sanitary sewer)	\$0
Other	Wet ponds and bioretention facilities	\$0
Environmental	Wetland and stream impacts	\$0
Environmental	Historic and archaeological resources	\$500,000
Other	40% contingency added to base construction cost	\$3,619,581
		<b>\$4,738,939</b>

Version 6.00

**SIGNALS, ITS, SIGNS and LIGHTING COST WORKSHEET**

Stand Alone Traffic Project:  No

UPC: 106724

**SIGNALS**

Permanent Signals	New/Mod.	Intersection Type	Major				Cross				Poles	Detection	Pre-emption	Cost
			Direction	Lanes	Direction	Lanes	Direction	Lanes	Direction	Lanes				
Location/Description														
1														\$0
2														\$0
3														\$0
4														\$0
5														\$0
6														\$0
7														\$0
8														\$0
9														\$0
10														\$0

Temporary Signals - New Equipment	Quantity	Cost
Temporary Signals - Modified Equipment		\$0

MISCELLANEOUS SIGNAL WORK	Location/Description	Cost
1		
2		

Signals Construction Subtotal \$0

**ITS**

ITS WORK	Location/Description	Cost
1		
2		

ITS Construction Subtotal \$0

**MAJOR SIGN STRUCTURES**

Type of Sign	Comment	Quantity	Unit	Lighted Y/N	Included in Roadway Lighting? yes/no	Cost/Sign	Extended Cost
1 O/H Span (50-100)	Every 1,300 feet both sides	10	Ea.	Yes		114,319	\$1,143,186
2			Ea.				
3			Ea.				
4			Ea.				
5			Ea.				
6			Ea.				
7			Ea.				

MISCELLANEOUS SIGN WORK	Location/Description	Cost
1	Add mile post markers at \$1,000/mile for 1.30 miles	\$1,300
2	Guide signs at directional 3-leg interchange	\$2,005,025

Signs Construction Subtotal \$3,149,511

**LIGHTING**

Continuous Roadway		Interchange		Miscellaneous		Number of Miles	Cost
Urban Type of Lighting	Comments	Interchange Type	Type of Lighting	Location/Description			
1		1	Conventional	1		1	\$664,376
Freeway Type of Lighting	Comments	2		2			\$0
1		3		3			\$0

Lighting Construction Subtotal \$1,316,218

**CONSTRUCTION TOTAL \$4,465,729**

*District factor will be applied when the total cost is passed to the const-1 worksheet*

**PROJECT COMMENTS**

Prepared by: CMS

Date Prepared/Modified: 05/05/16

Version 6.00

# BRIDGE CONSTRUCTION AND PRELIMINARY ENGINEERING COSTS

BRIDGE  
CONSTRUCTION

BRIDGE  
P. E.

Bridge Job #

Federal Structure ID

Manual CEI Cost Override :

Bridge # 1 CEI Cost :

11%

Manual PE Cost Adjustment :

Bridge #1 CN + CEI Cost :

P.E. Bridge # 1

BRIDGE #1 CN Cost : (input from Bridge PCES worksheet)

Comments - Constr. Engr. Br. #1:

Comments - Misc. P.E. Bridge #1:

Bridge Job #

Federal Structure ID

Manual CEI Cost Override :

Bridge # 2 CEI Cost :

11.0%

Manual PE Cost Adjustment :

Bridge #2 CN + CEI Cost :

P.E. Bridge # 2

BRIDGE #2 CN Cost : (input from Bridge PCES worksheet)

Comments - Constr. Engr. Br. #2:

Comments - Misc. P.E. Bridge #2:

Bridge Job #

Federal Structure ID

Manual CEI Cost Override :

Bridge # 3 CEI Cost :   
11.0%

Manual PE Cost Adjustment :

BRIDGE #3 CN Cost : (input from Bridge PCES worksheet)

Bridge #3 CN + CEI Cost :

P.E. Bridge # 3

Comments - Constr. Engr. Br. #3:

Comments - Misc. P.E. Bridge #3:

BRIDGE CONSTRUCTION AND PE COSTS (continued)

**BRIDGE  
CONSTRUCTION**

**BRIDGE  
P. E.**

Bridge Job #

Federal Structure ID

Manual CEI Cost Override :

Bridge # 4 CEI Cost :

11.0%

Manual PE Cost Adjustment :

Bridge #4 CN + CEI Cost :

P.E. Bridge # 4

BRIDGE #4 CN Cost : (input from Bridge PCES worksheet)

Comments - Constr. Engr. Br. #4:

Comments - Misc. P.E. Bridge #4:

Bridge Job #

Federal Structure ID

Manual CEI Cost Override :

Bridge # 5 CEI Cost :

11.0%

Manual PE Cost Adjustment :

Bridge #5 CN + CEI Cost :

P.E. Bridge # 5

BRIDGE #5 CN Cost : (input from Bridge PCES worksheet)

Comments - Constr. Engr. Br. #5:

Comments - Misc. P.E. Bridge #5:

Bridge Job #

Federal Structure ID

Manual CEI Cost Override :



Bridge # 6 CEI Cost :

\$6,193,550

11.0%

Manual PE Cost Adjustment :

BRIDGE #6 CN Cost : (input from Bridge PCES worksheet)



Bridge #6 CN + CEI Cost :

P.E. Bridge # 6

Comments - Constr. Engr. Br. #6:

Comments - Misc. P.E. Bridge #6:

BRIDGE CONSTRUCTION AND PE COSTS (continued)			
		<i>Bridge Construction Base (PCES)</i>	\$397,796,000
<i>Bike / PED Construction Cost</i>	\$0		
<i>Bike / PED CE</i>	\$0	<i>Bridge Removal</i>	\$0
<i>Bike / PED PE</i>	\$0	<i>Bridge CE (PCES)</i>	\$43,757,560
<b>NOTE : Structure Complexity is based upon Height,</b>		<b>Bridge Estimate. (2016)</b>	<b>\$441,553,560</b>
<b>Difficulty of Construction, and other Factors</b>		<b>Total Bridge P. E. Costs (PCES)</b>	<b>\$13,237,842</b>
			<b>Version 6.00</b>

 Project Cost Estimating System <b>COMMENTS</b> 		
<b>General / Miscellaneous Comments from CONST, RW, &amp; UTILITY Worksheets</b>	<b>Team Member and Section</b>	<b>Date Entered</b>
<b>1</b> Project terrain changed from rolling to level based on comments from L&D on draft cost estimate	C. Sutkowski - HRCS Team	06/23/16
<b>2</b> Moved 10% of roadway and structures costs for general utility relocation from CONST-MISC sheet to MANUAL sheet	C. Sutkowski - HRCS Team	06/27/16
<b>3</b> Input revised bridge costs based on comments from S&B on draft cost estimate	C. Sutkowski - HRCS Team	06/28/16
<b>4</b> Included costs for noise barriers in segment estimate as provided by noise team	C. Sutkowski - HRCS Team	06/29/16
<b>5</b> Updated costs for right-of-way with contingency added in line item in MANUAL sheet	C. Sutkowski - HRCS Team	06/29/16
<b>6</b>		
<b>7</b>		
<b>8</b>		
<b>9</b>		
<b>10</b>		
<b>11</b>		
<b>12</b>		
<b>13</b>		
<b>14</b>		
<b>15</b>		

UPC: 106724

**VDOT Project Cost Estimating System  
MANUAL ESTIMATE**

	DATE	PE	RW	CN
<b>EXPENDITURES</b>	01/20/16	\$839,552		\$0
<b>RUMS</b>	01/28/16			\$0
<b>TRNS*PORT</b>				\$0
<b>AWARD</b>	01/28/16			\$0
<b>PROJECTION</b>	01/28/16			\$0

**ESTIMATE YEAR**

**AD YEAR**

FY2016		FY2016
\$0	PE	\$0
\$43,771,448	RW	\$43,771,448
\$0	CN	\$0
\$43,771,448	<b>TOTAL</b>	\$43,771,448

Job #	Phase	Comment	Estimate
	RW	10% of roadway and structures costs for general utility relocation	\$40,173,567
	RW	Cost for utility work under RW project. See file Utilities Cost Estimate All Segments(AWP).xls	\$1,089,000
	RW	Cost for Right-of-Way. See file HRCS ROW Costs.xlsx	\$2,508,882
	RW	Cost for Right-of-Way for Stormwater Management. See file HRCS ROW Costs.xlsx	\$0

Job #	Phase	Comment	Estimate
-------	-------	---------	----------



# Project Cost Estimating System

## SUMMARY PAGE

DISTRICT	<b>HAMPTON ROADS</b>		
PROJECT NUMBER	<b>64965081</b>		
CONSTRUCTION END YEAR	<b>FY2016</b>	UPC	<b>106724</b>
AD YEAR	<b>FY2016</b>	RATE OF INFLATION TO AD	<b>N/A</b>
ESTIMATE YEAR	<b>FY2016</b>	INFLATION RATE DURING CN	<b>N/A</b>
Date of previous estimate	01/28/16		
PROJECT MANAGER / DESIGNER	<b>Scott.Smizik</b>		
Preliminary Engineering Estimate:	<b>PCES</b>		
Construction Estimate:	<b>PCES</b>		
Right-of-Way Estimate:	<b>MANUAL</b>		
Utilities Estimate:	<b>MANUAL</b>		
DATE	<b>6/30/2016</b>		

THE FOLLOWING DATA WILL BE PROVIDED UPON COMPLETION OF THE REMAINDER OF THE WORKBOOK, WHICH IS ACCESSED BY SELECTING THE CONST, RW, & UTIL TABS BELOW



CONSTRUCTION ESTIMATE	<b>\$259,080,175</b>
PRELIMINARY ENGINEERING ESTIMATE	<b>\$18,833,859</b>
RIGHT-OF-WAY & UTILITIES ESTIMATE	<b>\$31,139,598</b>
TOTAL PROJECT ESTIMATE	<b>\$309,053,632</b>

© Virginia Department of Transportation 2005

Revised 01/21/16

Estimate Class: Blank

Version 6.00

	Project Cost Estimating System CONSTRUCTION / BRIDGE / PE	
---	--	---

Project No. **64965081**

Interstate Project ?

Route Number   **Urban or Other**

	CONST-1	CONST-2	Bridges (0)	Total
Geometric Standard	GS-5			
Construction Base	\$135,282,751	\$0	\$95,841,000	\$231,123,751
Bridge Removal			\$0	\$0
CE	\$16,910,344		\$11,046,080	\$27,956,424
Construction Estimate (2016)	\$152,193,095		\$106,887,080	\$259,080,175
To AdYear Inflation				\$0
Mid-point construction Inflation				\$0
Total Construction Estimate			\$106,887,080	<b>\$259,080,175</b>
Preliminary Engineering Cost	\$14,001,765		\$4,832,094	\$18,833,859

### CONSTRUCTION & PE TOTALS

<b>Total Construction Estimate</b> (Roadway plus Bridge)	<b>\$259,080,175</b>	<b>PCES</b>
<b>Total Preliminary Engineering Estimate</b> (Roadway plus Bridge)	<b>\$18,833,859</b>	<b>PCES</b>

Project Cost Estimating System

CONSTRUCTION / BRIDGE / PE

Project No. **64965081**

Interstate Project ?	<input type="text" value="No"/>	*					
Maintenance Project ?	<input type="text" value="No"/>	*					
Route Number	<input type="text" value="164C"/>	*	Urban or Other				
Geometric Standard	<input type="text" value="GS-5"/>	*	Urban Principal Arterial System				
Ad Date	<input type="text" value="2016"/>		Design Year = 2038				
Design Year ADT	<input type="text" value="14,700"/>	*	Project Terrain <input type="text" value="Level"/>				
<i>Box Must Be Empty</i>	<input type="text"/>		Approx. DHV = 2,205				
Enter Design Speed (MPH) (30, 40, 45, 50 or 60)	<input type="text" value="70"/>	*	Minimum Design Speed = 70 MPH				
<i>Box Must Be Empty</i>	<input type="text"/>						
<i>Box Must Be Empty</i>	<input type="text"/>						
Project Length (mi.)	<input type="text" value="4.92"/>	*	<table border="0" style="width: 100%; border-collapse: collapse;"> <tr> <td style="text-align: center;"><i>Number of Additional Lanes:</i></td> <td style="text-align: center;"><i>Length of Add'l. Lanes (mi.):</i></td> </tr> <tr> <td><input type="text" value=""/></td> <td><input type="text" value="0.35"/></td> </tr> </table>	<i>Number of Additional Lanes:</i>	<i>Length of Add'l. Lanes (mi.):</i>	<input type="text" value=""/>	<input type="text" value="0.35"/>
<i>Number of Additional Lanes:</i>	<i>Length of Add'l. Lanes (mi.):</i>						
<input type="text" value=""/>	<input type="text" value="0.35"/>						
Total Length - Adding or Building <u>Two Lanes</u> (mi.)	<input type="text" value="1.50"/>	*	<input type="text" value="None"/>				
Total Length - Adding or Building <u>Four Lanes</u> (mi.)	<input type="text" value="2.41"/>	*	<input type="text" value="None"/>				
Total Length - Building <u>Ramps and Loops</u> (mi.)	<input type="text" value="4.16"/>	*	<input type="text" value="None"/>				
Shoulder or Curb & Gutter ? (Select S or C&G)	<input type="text" value="S"/>	*	Enter Lane Width (ft) > <input type="text"/>				
Median Type - Graded, Raised, or None ?	<input type="text" value="G"/>	*	Normal Lane Width(ft) <input type="text" value="12"/>				
Number of Crossovers (Divided Highways ONLY)	<input type="text"/>	*					
Length - Curb & Gutter - Left PLUS Right Side (ft.)	<input type="text"/>						
Length - Sidewalk - Left PLUS Right Side (ft.)	<input type="text"/>						
Bike / Pedestrian Type	<input type="text" value="None"/>						
Total Length - Raised Median (ft.)	<input type="text"/>						
Number of <u>Right Turn Lanes</u> - Left PLUS Right Side	<input type="text"/>	*					
Number of Left Turn Lanes - (Undivided Only)	<input type="text"/>	*					

**HAMPTON ROADS**  
 110% Cost Factor used

Construction Costs	
Base #1 (PCES)	<input type="text" value="\$135,282,751"/>
Base #2	<input type="text" value="\$0"/>
Enter Const CE Cost >	<input type="text" value="\$0"/>
CE (12.5%)	<input type="text" value="\$16,910,344"/>
Estimate (2016)	<input type="text" value="\$152,193,095"/>

Signals, ITS, Signs and Lighting Costs*	<input type="text" value="\$8,955,591"/>
Cost of Large Drainage Structures	<input type="text" value="\$71,200"/>
In-Plan Utility Costs*	<input type="text" value="\$0"/>
Adjustment for Unusual Construction Costs	<input type="text" value="\$80,073,945"/>

*\* Totals include district factor calculations*

Additional (or Unusual) P. E. Costs	<input type="text"/>		
Select % of PE to be performed by Consultants	<input type="text" value="30%"/>	PE Cost (PCES)	<input type="text" value="\$14,001,765"/>

**Note: Do Not Include Bridge P. E. Costs Here**



Roadway P. E. / Roadway Const. = 9.2%

© Virginia Department of Transportation 2005  
Revised 01/21/16

**Today's Date: 06/30/16**

**Version 6.00**



**Project Cost Estimating System**  
**Miscellaneous Cost Estimates**

**COST OF LARGE DRAINAGE STRUCTURES**

Job#	Description	Cost ()
XXXXXX	Culvert extension under WB VA-164; 0.05 mi west of Cedar Ln	\$35,600
XXXXXX	Culvert extension under EB VA-164; 0.05 mi west of Cedar Ln	\$35,600
		<b>\$71,200</b>

**ADJUSTMENT FOR UNUSUAL CONSTRUCTION COSTS**

Type	Description	Cost ()
Maintenance of Traffic	20% of roadway costs for MOT	\$13,261,263
Other	5% of roadway and structures costs for landscaping	\$8,107,366
Other	Resurfacing existing roadways	\$1,915,675
Other	Excessive excavation	\$0
Other	Excessive borrow	\$14,467,496
Other	Concrete barrier	\$252,283
Other	Guardrail and end treatments	\$782,764
Other	Removal of existing guardrail	\$71,736
Other	Demolition of existing pavement	\$363,148
Other	Noise barriers	\$0
Other	Retaining walls	\$0
Other	Tunnel costs	\$0
Other	Major in-plan utility work (water and sanitary sewer)	\$0
Other	Wet ponds and bioretention facilities	\$1,700,000
Environmental	Wetland and stream impacts	\$0
Environmental	Historic and archaeological resources	\$500,000
Other	40% contingency added to base construction cost	\$38,652,214
		<b>\$80,073,945</b>

Version 6.00

### SIGNALS, ITS, SIGNS and LIGHTING COST WORKSHEET

Stand Alone Traffic Project:  No

UPC: 106724

SIGNALS		New/Mod.	Intersection Type	Major				Cross				Poles	Detection	Pre-emption	Cost
Permanent Signals				Direction	Lanes	Direction	Lanes	Direction	Lanes	Direction	Lanes				
Location/Description															
1	VA 164 at Cedar Lar	New	Offset	North	2	South	2	East	1	West	1	Mast Arm	None	No	\$158,425
2															\$0
3															\$0
4															\$0
5															\$0
6															\$0
7															\$0
8															\$0
9															\$0
10															\$0

Temporary Signals - New Equipment	Quantity	Cost
Temporary Signals - Modified Equipment		\$0

MISCELLANEOUS SIGNAL WORK		Location/Description	Cost
1			
2			

Signals Construction Subtotal \$158,425

ITS		Location/Description	Cost
ITS WORK			
1			
2			

ITS Construction Subtotal \$0

MAJOR SIGN STRUCTURES							
Type of Sign	Comment	Quantity	Unit	Lighted Y/N	Included in Roadway Lighting? yes/no	Cost/Sign	Extended Cost
1	O/H Span (50-100)	Every 1,300 feet both sides	30	Ea.	Yes	114,319	\$3,429,559
2				Ea.			
3				Ea.			
4				Ea.			
5				Ea.			
6				Ea.			
7				Ea.			

MISCELLANEOUS SIGN WORK		Location/Description	Cost
1		Add mile post markers at \$1,000/mile for 3.75 miles	\$3,750
2		Guide signs at directional 3-leg interchange	\$2,005,025

Signs Construction Subtotal \$5,438,334

LIGHTING						
Continuous Roadway						
Urban Type of Lighting		Comments	No. Lanes	Number of Miles	Cost	
1					\$0	
Freeway Type of Lighting		Comments	No. Lanes	Number of Miles	Cost	
1	Conventional		4	3.75	\$1,880,311	
Interchange						
Interchange Type		Type of Lighting	Number of Interchanges		Cost	
1	Diamond	Conventional	1		\$664,376	
2					\$0	
3					\$0	
Miscellaneous						
		Location/Description			Cost	
1						
2						

Lighting Construction Subtotal \$2,544,687

**CONSTRUCTION TOTAL \$8,141,447**

District factor will be applied when the total cost is passed to the const-1 worksheet

**PROJECT COMMENTS**

Prepared by:

Date Prepared/Modified:

Version 6.00

# BRIDGE CONSTRUCTION AND PRELIMINARY ENGINEERING COSTS

BRIDGE  
CONSTRUCTION

BRIDGE  
P. E.

Bridge Job #

Federal Structure ID

Manual CEI Cost Override :

Bridge # 1 CEI Cost :

17%

Manual PE Cost Adjustment :

Bridge #1 CN + CEI Cost :

P.E. Bridge # 1

BRIDGE #1 CN Cost : (input from Bridge PCES worksheet)

Comments - Constr. Engr. Br. #1:

Comments - Misc. P.E. Bridge #1:

Bridge Job #

Federal Structure ID

Manual CEI Cost Override :

Bridge # 2 CEI Cost :

17.0%

Manual PE Cost Adjustment :

Bridge #2 CN + CEI Cost :

P.E. Bridge # 2

BRIDGE #2 CN Cost : (input from Bridge PCES worksheet)

Comments - Constr. Engr. Br. #2:

Comments - Misc. P.E. Bridge #2:

Bridge Job #

Federal Structure ID

Manual CEI Cost Override :

Bridge # 3 CEI Cost :   
15.0%

Manual PE Cost Adjustment :

BRIDGE #3 CN Cost : (input from Bridge PCES worksheet)

Bridge #3 CN + CEI Cost :

P.E. Bridge # 3

Comments - Constr. Engr. Br. #3:

Comments - Misc. P.E. Bridge #3:

BRIDGE CONSTRUCTION AND PE COSTS (continued)

BRIDGE  
CONSTRUCTION

BRIDGE  
P. E.

Bridge Job #

Federal Structure ID

Manual CEI Cost Override :

Bridge # 4 CEI Cost :

11.0%

Manual PE Cost Adjustment :

BRIDGE #4 CN Cost : (input from Bridge PCES worksheet)

Bridge #4 CN + CEI Cost :

P.E. Bridge # 4

Comments - Constr. Engr. Br. #4:

Comments - Misc. P.E. Bridge #4:

Bridge Job #

Federal Structure ID

Manual CEI Cost Override :

Bridge # 5 CEI Cost :

11.0%

Manual PE Cost Adjustment :

BRIDGE #5 CN Cost : (input from Bridge PCES worksheet)

Bridge #5 CN + CEI Cost :

P.E. Bridge # 5

Comments - Constr. Engr. Br. #5:

Comments - Misc. P.E. Bridge #5:

Bridge Job #

Federal Structure ID

Manual CEI Cost Override :

Bridge # 6 CEI Cost :

14.0%

Manual PE Cost Adjustment :

BRIDGE #6 CN Cost : (input from Bridge PCES worksheet)

Bridge #6 CN + CEI Cost :

P.E. Bridge # 6

Comments - Constr. Engr. Br. #6:

Comments - Misc. P.E. Bridge #6:

BRIDGE CONSTRUCTION AND PE COSTS (continued)

BRIDGE CONSTRUCTION

BRIDGE P. E.

Bridge Job #

[Yellow box]

Federal Structure ID

[Yellow box] 4

Manual CEI Cost Override :

[Yellow box]

Bridge # 7 CEI Cost : \$1,150,050  
11.0%

Manual PE Cost Adjustment :

[Yellow box]

Bridge #7 CN + CEI Cost :

P.E. Bridge # 7

BRIDGE #7 CN Cost : (input from Bridge PCES worksheet) \$10,455,000

\$11,605,050

\$450,003

Comments - Constr. Engr. Br. #7:

[White box]

Comments - Misc. P.E. Bridge #7:

[White box]

Bridge Job #

[Yellow box]

Federal Structure ID

[Yellow box] 5

Manual CEI Cost Override :

[Yellow box]

Bridge # 8 CEI Cost : \$293,250  
15.0%

Manual PE Cost Adjustment :

[Yellow box]

Bridge #8 CN + CEI Cost :

P.E. Bridge # 8

BRIDGE #8 CN Cost : (input from Bridge PCES worksheet) \$1,955,000

\$2,248,250

\$182,678

Comments - Constr. Engr. Br. #8:

[White box]

Comments - Misc. P.E. Bridge #8:

[White box]

Bridge Job #

[Yellow box]

Federal Structure ID

[Yellow box] 6

Manual CEI Cost Override :

Bridge # 9 CEI Cost :

16.0%

Manual PE Cost Adjustment :

BRIDGE #9 CN Cost : (input from Bridge PCES worksheet)

Bridge #9 CN + CEI Cost :

P.E. Bridge # 9

Comments - Constr. Engr. Br. #9:

Comments - Misc. P.E. Bridge #9:



BRIDGE CONSTRUCTION AND PE COSTS (continued)

BRIDGE CONSTRUCTION

BRIDGE P. E.

Bridge Job #

[Yellow box]

Federal Structure ID

[Yellow box] 15

Manual CEI Cost Override :

[Yellow box]

Bridge # 10 CEI Cost :

[Blue box] \$2,241,140

11.0%

Manual PE Cost Adjustment :

[Yellow box]

Bridge #10 CN + CEI Cost :

[Blue box] \$22,615,140

P.E. Bridge # 10

[Blue box] \$761,955

BRIDGE #10 CN Cost : (input from Bridge PCES worksheet)

[Green box] \$20,374,000

Comments - Constr. Engr. Br. #10:

[White box]

Comments - Misc. P.E. Bridge #10:

[White box]

Bridge Job #

[Yellow box]

Federal Structure ID

[Yellow box] 27

Manual CEI Cost Override :

[Yellow box]

Bridge # 11 CEI Cost :

[Blue box] \$2,241,140

11.0%

Manual PE Cost Adjustment :

[Yellow box]

Bridge #11 CN + CEI Cost :

[Blue box] \$22,615,140

P.E. Bridge # 11

[Blue box] \$761,955

BRIDGE #11 CN Cost : (input from Bridge PCES worksheet)

[Green box] \$20,374,000

Comments - Constr. Engr. Br. #11:

[White box]

Comments - Misc. P.E. Bridge #11:

[White box]

Bridge Job #

[Yellow box]

Federal Structure ID

[Yellow box] 16

Manual CEI Cost Override :

[Yellow box]

Bridge # 12 CEI Cost : \$750,640  
11.0%

Manual PE Cost Adjustment :  

BRIDGE #12 CN Cost : (input from Bridge PCES worksheet) \$6,824,000

Bridge #12 CN + CEI Cost : \$7,574,640

P.E. Bridge # 12 \$335,808

Comments - Constr. Engr. Br. #12:

Comments - Misc. P.E. Bridge #12:

BRIDGE CONSTRUCTION AND PE COSTS (continued)

BRIDGE CONSTRUCTION

BRIDGE P. E.

Bridge Job #

[Yellow box]

Federal Structure ID

17

Manual CEI Cost Override :

[Yellow box]

Bridge # 13 CEI Cost :

\$451,100

13.0%

Manual PE Cost Adjustment :

[Yellow box]

Bridge #13 CN + CEI Cost :

P.E. Bridge # 13

BRIDGE #13 CN Cost : (input from Bridge PCES worksheet)

\$3,470,000

\$3,921,100

\$230,325

Comments - Constr. Engr. Br. #13:

[White box]

Comments - Misc. P.E. Bridge #13:

[White box]

Bridge Job #

[Yellow box]

Federal Structure ID

18

Manual CEI Cost Override :

[Yellow box]

Bridge # 14 CEI Cost :

\$435,760

13.0%

Manual PE Cost Adjustment :

[Yellow box]

Bridge #14 CN + CEI Cost :

P.E. Bridge # 14

BRIDGE #14 CN Cost : (input from Bridge PCES worksheet)

\$3,352,000

\$3,787,760

\$226,613

Comments - Constr. Engr. Br. #14:

[White box]

Comments - Misc. P.E. Bridge #14:

[White box]

Bridge Job #

[Yellow box]

Federal Structure ID

21197

Manual CEI Cost Override :

Bridge # 15 CEI Cost :

11.0%

Manual PE Cost Adjustment :

BRIDGE #15 CN Cost : (input from Bridge PCES worksheet)



Bridge #15 CN + CEI Cost :

P.E. Bridge # 15

Comments - Constr. Engr. Br. #15:

Comments - Misc. P.E. Bridge #15:

BRIDGE CONSTRUCTION AND PE COSTS (continued)			
		<i>Bridge Construction Base (PCES)</i>	\$95,841,000
<i>Bike / PED Construction Cost</i>	\$0		
<i>Bike / PED CE</i>	\$0	<i>Bridge Removal</i>	\$0
<i>Bike / PED PE</i>	\$0	<i>Bridge CE (PCES)</i>	\$11,046,080
<b>NOTE : Structure Complexity is based upon Height,</b>		<b>Bridge Estimate. (2016)</b>	<b>\$106,887,080</b>
<b>Difficulty of Construction, and other Factors</b>		<b>Total Bridge P. E. Costs (PCES)</b>	<b>\$4,832,094</b>
			<b>Version 6.00</b>

 <b>Project Cost Estimating System</b> 		
<b>COMMENTS</b>		
<b>General / Miscellaneous Comments from CONST, RW, &amp; UTILITY Worksheets</b>	<b>Team Member and Section</b>	<b>Date Entered</b>
<b>1</b> Project terrain changed from rolling to level based on comments from L&D on draft cost estimate	C. Sutkowski - HRCS Team	06/23/16
<b>2</b> Moved 10% of roadway and structures costs for general utility relocation from CONST-MISC sheet to MANUAL sheet	C. Sutkowski - HRCS Team	06/27/16
<b>3</b> Input revised bridge costs based on comments from S&B on draft cost estimate	C. Sutkowski - HRCS Team	06/28/16
<b>4</b> Included costs for noise barriers in segment estimate as provided by noise team	C. Sutkowski - HRCS Team	06/29/16
<b>5</b> Updated costs for right-of-way with contingency added in line item in MANUAL sheet	C. Sutkowski - HRCS Team	06/29/16
<b>6</b> Added costs for right-of-way for stormwater management in MANUAL sheet	C. Sutkowski - HRCS Team	06/29/16
<b>7</b>		
<b>8</b>		
<b>9</b>		
<b>10</b>		
<b>11</b>		
<b>12</b>		
<b>13</b>		
<b>14</b>		
<b>15</b>		

**VDOT Project Cost Estimating System  
MANUAL ESTIMATE**

	DATE	PE	RW	CN
<b>EXPENDITURES</b>	01/20/16	\$839,552		\$0
<b>RUMS</b>	01/28/16			\$0
<b>TRNS*PORT</b>				\$0
<b>AWARD</b>	01/28/16			\$0
<b>PROJECTION</b>	01/28/16			\$0

**ESTIMATE YEAR**

**AD YEAR**

FY2016		FY2016
\$0	PE	\$0
\$31,139,598	RW	\$31,139,598
\$0	CN	\$0
\$31,139,598	<b>TOTAL</b>	\$31,139,598

Job #	Phase	Comment	Estimate
	RW	10% of roadway and structures costs for general utility relocation	\$16,214,732
	RW	Cost for utility work under RW project. See file Utilities Cost Estimate All Segments(AWP).xls	\$3,729,825
	RW	Cost for Right-of-Way. See file HRCS ROW Costs.xlsx	\$10,792,547
	RW	Cost for Right-of-Way for Stormwater Management. See file HRCS ROW Costs.xlsx	\$402,494

Job #	Phase	Comment	Estimate
-------	-------	---------	----------



## Project Cost Estimating System SUMMARY PAGE

<b>DISTRICT</b>	<b>HAMPTON ROADS</b>		
<b>PROJECT NUMBER</b>	<b>64965081</b>		
<b>CONSTRUCTION END YEAR</b>	<b>FY2016</b>	<b>UPC</b>	<b>106724</b>
<b>AD YEAR</b>	<b>FY2016</b>	<small>RATE OF INFLATION TO AD</small>	<b>N/A</b>
<b>ESTIMATE YEAR</b>	<b>FY2016</b>	<small>INFLATION RATE DURING CN</small>	<b>N/A</b>
<small>Date of previous estimate</small>	01/28/16		
<b>PROJECT MANAGER / DESIGNER</b>	<b>Scott.Smizik</b>		
<b>Preliminary Engineering Estimate:</b>	<b>PCES</b>		
<b>Construction Estimate:</b>	<b>PCES</b>		
<b>Right-of-Way Estimate:</b>	<b>MANUAL</b>		
<b>Utilities Estimate:</b>	<b>MANUAL</b>		
<b>DATE</b>	<b>6/30/2016</b>		

THE FOLLOWING DATA WILL BE PROVIDED UPON COMPLETION OF THE REMAINDER OF THE WORKBOOK, WHICH IS ACCESSED BY SELECTING THE CONST, RW, & UTIL TABS BELOW

<b>CONSTRUCTION ESTIMATE</b>	<b>\$28,476,225</b>
<b>PRELIMINARY ENGINEERING ESTIMATE</b>	<b>\$2,619,813</b>
<b>RIGHT-OF-WAY &amp; UTILITIES ESTIMATE</b>	<b>\$67,524,069</b>
<b>TOTAL PROJECT ESTIMATE</b>	<b>\$98,620,107</b>



© Virginia Department of Transportation 2005

Revised 01/21/16

Estimate Class: Blank

Version 6.00



	Project Cost Estimating System CONSTRUCTION / BRIDGE / PE	
---	--	---

Project No. **64965081**

Interstate Project ?

Route Number   Urban or Other

	CONST-1	CONST-2	Bridges (0)	Total
Geometric Standard	GS-5			
Construction Base	\$25,312,200	\$0	\$0	\$25,312,200
Bridge Removal			\$0	\$0
CE	\$3,164,025		\$0	\$3,164,025
Construction Estimate (2016)	\$28,476,225		\$0	\$28,476,225
To AdYear Inflation				\$0
Mid-point construction Inflation				\$0
Total Construction Estimate			\$0	<b>\$28,476,225</b>
Preliminary Engineering Cost	\$2,619,813		\$0	\$2,619,813

### CONSTRUCTION & PE TOTALS

Total Construction Estimate <i>(Roadway plus Bridge)</i>	<b>\$28,476,225</b>	<b>PCES</b>
Total Preliminary Engineering Estimate <i>(Roadway plus Bridge)</i>	<b>\$2,619,813</b>	<b>PCES</b>

Project Cost Estimating System

CONSTRUCTION / BRIDGE / PE

Project No. **64965081**

Interstate Project ?	<input type="text" value="No"/>	*					
Maintenance Project ?	<input type="text" value="No"/>	*					
Route Number	<input type="text" value="164C"/>	*	Urban or Other				
Geometric Standard	<input type="text" value="GS-5"/>	*	Urban Principal Arterial System				
Ad Date	<input type="text" value="2016"/>		Design Year = <input type="text" value="2038"/>				
Design Year ADT	<input type="text" value="14,700"/>	*	Project Terrain <input type="text" value="Level"/>				
<i>Box Must Be Empty</i>	<input type="text"/>		Approx. DHV = <input type="text" value="2,205"/>				
Enter Design Speed (MPH) (30, 40, 45, 50 or 60)	<input type="text" value="70"/>	*	Design Speed = <input type="text" value="70 MPH"/>				
<i>Box Must Be Empty</i>	<input type="text"/>						
<i>Box Must Be Empty</i>	<input type="text"/>						
Project Length (mi.)	<input type="text" value="0.66"/>	*	<table border="0" style="margin-left: auto; margin-right: auto;"> <tr> <td style="text-align: center;"><i>Number of Additional Lanes:</i></td> <td style="text-align: center;"><i>Length of Add'l. Lanes (mi.):</i></td> </tr> <tr> <td style="text-align: center;"><input type="text"/></td> <td style="text-align: center;"><input type="text"/></td> </tr> </table>	<i>Number of Additional Lanes:</i>	<i>Length of Add'l. Lanes (mi.):</i>	<input type="text"/>	<input type="text"/>
<i>Number of Additional Lanes:</i>	<i>Length of Add'l. Lanes (mi.):</i>						
<input type="text"/>	<input type="text"/>						
Total Length - Adding or Building <u>Two Lanes</u> (mi.)	<input type="text"/>	*	<input type="text"/>				
Total Length - Adding or Building <u>Four Lanes</u> (mi.)	<input type="text" value="0.66"/>	*	<input type="text" value="None"/>				
Total Length - Building <u>Ramps and Loops</u> (mi.)	<input type="text"/>	*	<input type="text" value="None"/>				
Shoulder or Curb & Gutter ? (Select S or C&G)	<input type="text" value="S"/>	*	Enter Lane Width (ft) > <input type="text"/>				
Median Type - Graded, Raised, or None ?	<input type="text" value="G"/>	*	Normal Lane Width(ft) <input type="text" value="12"/>				
Number of Crossovers (Divided Highways ONLY)	<input type="text"/>	*					
Length - Curb & Gutter - Left PLUS Right Side (ft.)	<input type="text"/>						
Length - Sidewalk - Left PLUS Right Side (ft.)	<input type="text"/>						
Bike / Pedestrian Type	<input type="text" value="None"/>						
Total Length - Raised Median (ft.)	<input type="text"/>						
Number of <u>Right Turn Lanes</u> - Left PLUS Right Side	<input type="text"/>	*					
Number of Left Turn Lanes - (Undivided Only)	<input type="text"/>	*					

**HAMPTON ROADS**  
 110% Cost Factor used  
**Construction Costs**

Signals, ITS, Signs and Lighting Costs*	<input type="text" value="\$1,119,257"/>		Base #1 (PCES)	<input type="text" value="\$25,312,200"/>
Cost of Large Drainage Structures	<input type="text" value="\$0"/>		Base #2	<input type="text" value="\$0"/>
In-Plan Utility Costs*	<input type="text" value="\$0"/>		Enter Const CE Cost >	<input type="text" value="\$0"/>
Adjustment for Unusual Construction Costs	<input type="text" value="\$20,107,993"/>		CE (12.5%)	<input type="text" value="\$3,164,025"/>
<i>* Totals include district factor calculations</i>			Estimate (2016)	<input type="text" value="\$28,476,225"/>

Additional (or Unusual) P. E. Costs	<input type="text"/>	
Select % of PE to be performed by Consultants	<input type="text" value="30%"/>	PE Cost (PCES) <input type="text" value="\$2,619,813"/>



**Note: Do Not Include Bridge P. E. Costs Here**

Roadway P. E. / Roadway Const. = 9.2%

© Virginia Department of Transportation 2005  
Revised 01/21/16

**Today's Date: 06/30/16**

**Version 6.00**

	<b>Project Cost Estimating System</b> Miscellaneous Cost Estimates	
---	---	---

**COST OF LARGE DRAINAGE STRUCTURES**

Job#	Description	Cost ()
		<b>\$0</b>

**ADJUSTMENT FOR UNUSUAL CONSTRUCTION COSTS**

Type	Description	Cost ()
Maintenance of Traffic	5% of roadway costs for MOT	\$770,949
Other	5% of roadway and structures costs for landscaping	\$770,949
Other	Resurfacing existing roadways	\$0
Other	Excessive excavation	\$0
Other	Excessive borrow	\$5,514,270
Other	Concrete barrier	\$0
Other	Guardrail and end treatments	\$87,957
Other	Removal of existing guardrail	\$0
Other	Demolition of existing pavement	\$0
Other	Noise barriers	\$0
Other	Retaining walls	\$0
Other	Tunnel costs	\$0
Other	Major in-plan utility work (water and sanitary sewer)	\$926,860
Other	Wet ponds and bioretention facilities	\$650,000
Environmental	Wetland and stream impacts	\$2,154,950
Environmental	Historic and archaeological resources	\$2,000,000
Other	40% contingency added to base construction cost	\$7,232,057
		<b>\$20,107,993</b>

Version 6.00

**SIGNALS, ITS, SIGNS and LIGHTING COST WORKSHEET**

Stand Alone Traffic Project:  No

UPC: 106724

**SIGNALS**

Permanent Signals	New/Mod.	Intersection Type	Major				Cross				Poles	Detection	Pre-emption	Cost
			Direction	Lanes	Direction	Lanes	Direction	Lanes	Direction	Lanes				
Location/Description														
1														\$0
2														\$0
3														\$0
4														\$0
5														\$0
6														\$0
7														\$0
8														\$0
9														\$0
10														\$0

	Quantity	Cost
Temporary Signals - New Equipment		\$0
Temporary Signals - Modified Equipment		\$0

MISCELLANEOUS SIGNAL WORK	Location/Description	Cost
1		
2		
<b>Signals Construction Subtotal</b>		<b>\$0</b>

ITS	Location/Description	Cost
ITS WORK	1	
	2	
<b>ITS Construction Subtotal</b>		<b>\$0</b>

MAJOR SIGN STRUCTURES	Type of Sign	Comment	Quantity	Unit	Lighted Y/N	Included in Roadway Lighting? yes/no	Cost/Sign	Extended Cost
1	O/H Span (50-100)	Every 1,300 feet both sides	6	Ea.	Yes		114,319	\$685,912
2				Ea.				
3				Ea.				
4				Ea.				
5				Ea.				
6				Ea.				
7				Ea.				
MISCELLANEOUS 1	Location/Description							Cost
SIGN WORK	1	Add mile post markers at \$1,000/mile for 0.66 miles						\$660
	2							
<b>Signs Construction Subtotal</b>								<b>\$686,572</b>

LIGHTING	Continuous Roadway	Urban Type of Lighting	Comments	No. Lanes	Number of Miles	Cost
	1					\$0
	1	Freeway Type of Lighting	Comments	No. Lanes	Number of Miles	Cost
	1	Conventional		4	0.66	\$330,935
	Interchange	Interchange Type	Type of Lighting		Number of Interchanges	Cost
	1					\$0
	2					\$0
	3					\$0
	Miscellaneous	Location/Description				Cost
	1					
	2					
<b>Lighting Construction Subtotal</b>						<b>\$330,935</b>
<b>CONSTRUCTION TOTAL</b>						<b>\$1,017,507</b>

*District factor will be applied when the total cost is passed to the const-1 worksheet*

PROJECT COMMENTS

Prepared by: CMS

Date Prepared/Modified: 05/05/16

Version 6.00

# BRIDGE CONSTRUCTION AND PRELIMINARY ENGINEERING COSTS

BRIDGE  
CONSTRUCTION

BRIDGE  
P. E.

Bridge Job #

Federal Structure ID

Manual CEI Cost Override :

Bridge # 1 CEI Cost :  18%

Manual PE Cost Adjustment :

Bridge #1 CN + CEI Cost :

P.E. Bridge # 1

BRIDGE #1 CN Cost : (input from Bridge PCES worksheet)

Comments - Constr. Engr. Br. #1:

Comments - Misc. P.E. Bridge #1:

Bridge Job #

Federal Structure ID

Manual CEI Cost Override :

Bridge # 2 CEI Cost :  18.0%

Manual PE Cost Adjustment :

Bridge #2 CN + CEI Cost :

P.E. Bridge # 2

BRIDGE #2 CN Cost : (input from Bridge PCES worksheet)

Comments - Constr. Engr. Br. #2:



Comments - Misc. P.E. Bridge #2:

Bridge Job #

Federal Structure ID

BRIDGE CONSTRUCTION AND PE COSTS (continued)				
	<i>Bike / PED Construction Cost</i>	\$0	<i>Bridge Construction Base (PCES)</i>	\$0
	<i>Bike / PED CE</i>	\$0	<i>Bridge Removal</i>	\$0
	<i>Bike / PED PE</i>	\$0	<i>Bridge CE (PCES)</i>	\$0
<b>NOTE :</b>	<b>Structure Complexity is based upon Height,</b>		<b>Bridge Estimate. (2016)</b>	<b>\$0</b>
	<b>Difficulty of Construction, and other Factors</b>		<b>Total Bridge P. E. Costs (PCES)</b>	<b>\$0</b>

Version 6.00

 Project Cost Estimating System <b>COMMENTS</b> 		
<b>General / Miscellaneous Comments from CONST, RW, &amp; UTILITY Worksheets</b>	<b>Team Member and Section</b>	<b>Date Entered</b>
<b>1</b> Project terrain changed from rolling to level based on comments from L&D on draft cost estimate	C. Sutkowski - HRCS Team	06/23/16
<b>2</b> Moved 10% of roadway and structures costs for general utility relocation from CONST-MISC sheet to MANUAL sheet	C. Sutkowski - HRCS Team	06/27/16
<b>3</b> Input revised bridge costs based on comments from S&B on draft cost estimate	C. Sutkowski - HRCS Team	06/28/16
<b>4</b> Included costs for noise barriers in segment estimate as provided by noise team	C. Sutkowski - HRCS Team	06/29/16
<b>5</b> Updated costs for right-of-way with contingency added in line item in MANUAL sheet	C. Sutkowski - HRCS Team	06/29/16
<b>6</b> Added costs for right-of-way for stormwater management in MANUAL sheet	C. Sutkowski - HRCS Team	06/29/16
<b>7</b>		
<b>8</b>		
<b>9</b>		
<b>10</b>		
<b>11</b>		
<b>12</b>		
<b>13</b>		
<b>14</b>		
<b>15</b>		



**VDOT Project Cost Estimating System  
MANUAL ESTIMATE**

	DATE	PE	RW	CN
<b>EXPENDITURES</b>	01/20/16	\$839,552		\$0
<b>RUMS</b>	01/28/16			\$0
<b>TRNS*PORT</b>				\$0
<b>AWARD</b>	01/28/16			\$0
<b>PROJECTION</b>	01/28/16			\$0

**ESTIMATE YEAR**

**AD YEAR**

FY2016		FY2016
\$0	PE	\$0
\$67,524,069	RW	\$67,524,069
\$0	CN	\$0
\$67,524,069	<b>TOTAL</b>	\$67,524,069

Job #	Phase	Comment	Estimate
	RW	10% of roadway and structures costs for general utility relocation	\$1,541,899
	RW	Cost for utility work under RW project. See file Utilities Cost Estimate All Segments(AWP).xls	\$16,573,452
	RW	Cost for Right-of-Way. See file HRCS ROW Costs.xlsx	\$49,271,175
	RW	Cost for Right-of-Way for Stormwater Management. See file HRCS ROW Costs.xlsx	\$137,543

Job #	Phase	Comment	Estimate
-------	-------	---------	----------



# Project Cost Estimating System

## SUMMARY PAGE

DISTRICT	<b>HAMPTON ROADS</b>		
PROJECT NUMBER	<b>64965081</b>		
CONSTRUCTION END YEAR	<b>FY2016</b>	UPC	<b>106724</b>
AD YEAR	<b>FY2016</b>	RATE OF INFLATION TO AD	<b>N/A</b>
ESTIMATE YEAR	<b>FY2016</b>	INFLATION RATE DURING CN	<b>N/A</b>
Date of previous estimate	01/28/16		
PROJECT MANAGER / DESIGNER	<b>Scott.Smizik</b>		
Preliminary Engineering Estimate:	<b>PCES</b>		
Construction Estimate:	<b>PCES</b>		
Right-of-Way Estimate:	<b>MANUAL</b>		
Utilities Estimate:	<b>MANUAL</b>		
DATE	<b>7/11/2016</b>		

THE FOLLOWING DATA WILL BE PROVIDED UPON COMPLETION OF THE REMAINDER OF THE WORKBOOK, WHICH IS ACCESSED BY SELECTING THE CONST, RW, & UTIL TABS BELOW

CONSTRUCTION ESTIMATE	<b>\$104,093,232</b>
PRELIMINARY ENGINEERING ESTIMATE	<b>\$8,959,721</b>
RIGHT-OF-WAY & UTILITIES ESTIMATE	<b>\$6,354,718</b>
TOTAL PROJECT ESTIMATE	<b>\$119,407,671</b>

© Virginia Department of Transportation 2005

Revised 01/21/16

Estimate Class: Blank

Version 6.00

Project Cost Estimating System  
CONSTRUCTION / BRIDGE / PE

Project No. **64965081**

Interstate Project ?

Route Number   **Primary Highway**

	CONST-1	CONST-2	Bridges (0)	Total
Geometric Standard	GS-5			
Construction Base	\$80,536,540	\$0	\$12,140,000	\$92,676,540
Bridge Removal			\$0	\$0
CE	\$10,067,067		\$1,349,625	\$11,416,692
Construction Estimate (2016)	\$90,603,607		\$13,489,625	\$104,093,232
To AdYear Inflation				\$0
Mid-point construction Inflation				\$0
Total Construction Estimate			\$13,489,625	<b>\$104,093,232</b>
Preliminary Engineering Cost	\$8,335,532		\$624,189	\$8,959,721

### CONSTRUCTION & PE TOTALS

**Total Construction Estimate** **\$104,093,232** **PCES**  
 (Roadway plus Bridge)

**Total Preliminary Engineering Estimate** **\$8,959,721** **PCES**  
 (Roadway plus Bridge)

Project Cost Estimating System

CONSTRUCTION / BRIDGE / PE

Project No. **64965081**

Interstate Project ?	<input type="text" value="No"/>	*									
Maintenance Project ?	<input type="text" value="No"/>	*									
Route Number	<input type="text" value="164"/>	*	Primary Highway								
Geometric Standard	<input type="text" value="GS-5"/>	*	Urban Principal Arterial System								
Ad Date	<input type="text" value="2016"/>		Design Year = 2038								
Design Year ADT	<input type="text" value="40,300"/>	*	Project Terrain <input type="text" value="Level"/>								
<i>Box Must Be Empty</i>	<input type="text"/>		Approx. DHV = 6,045								
Enter Design Speed (MPH) (30, 40, 45, 50 or 60)	<input type="text" value="70"/>	*	Design Speed = 70 MPH								
<i>Box Must Be Empty</i>	<input type="text"/>										
<i>Box Must Be Empty</i>	<input type="text"/>										
Project Length (mi.)	<input type="text" value="2.54"/>	*	<table border="0" style="width: 100%; border-collapse: collapse;"> <tr> <td style="width: 50%; text-align: center;"><i>Number of Additional Lanes:</i></td> <td style="width: 50%; text-align: center;"><i>Length of Add'l. Lanes (mi.):</i></td> </tr> <tr> <td style="text-align: center;"><input type="text" value="2.20"/></td> <td style="text-align: center;"><input type="text" value="0.20"/></td> </tr> <tr> <td style="text-align: center;"><input type="text" value="None"/></td> <td style="text-align: center;"><input type="text"/></td> </tr> <tr> <td style="text-align: center;"><input type="text" value="None"/></td> <td style="text-align: center;"><input type="text"/></td> </tr> </table>	<i>Number of Additional Lanes:</i>	<i>Length of Add'l. Lanes (mi.):</i>	<input type="text" value="2.20"/>	<input type="text" value="0.20"/>	<input type="text" value="None"/>	<input type="text"/>	<input type="text" value="None"/>	<input type="text"/>
<i>Number of Additional Lanes:</i>	<i>Length of Add'l. Lanes (mi.):</i>										
<input type="text" value="2.20"/>	<input type="text" value="0.20"/>										
<input type="text" value="None"/>	<input type="text"/>										
<input type="text" value="None"/>	<input type="text"/>										
Total Length - Adding or Building <u>Two Lanes</u> (mi.)	<input type="text" value="2.20"/>	*									
Total Length - Adding or Building <u>Four Lanes</u> (mi.)	<input type="text"/>	*									
Total Length - Building <u>Ramps and Loops</u> (mi.)	<input type="text"/>	*									
Shoulder or Curb & Gutter ? (Select S or C&G)	<input type="text" value="S"/>	*	Enter Lane Width (ft) > <input type="text"/>								
Median Type - Graded, Raised, or None ?	<input type="text" value="G"/>	*	Normal Lane Width(ft) <input type="text" value="12"/>								
Number of Crossovers (Divided Highways ONLY)	<input type="text"/>	*									
Length - Curb & Gutter - Left PLUS Right Side (ft.)	<input type="text"/>										
Length - Sidewalk - Left PLUS Right Side (ft.)	<input type="text"/>										
Bike / Pedestrian Type	<input type="text" value="None"/>										
Total Length - Raised Median (ft.)	<input type="text"/>										
Number of <u>Right Turn Lanes</u> - Left PLUS Right Side	<input type="text"/>	*									
Number of Left Turn Lanes - (Undivided Only)	<input type="text"/>	*									

**HAMPTON ROADS**  
 110% Cost Factor used

<b>Construction Costs</b>	
Base #1 (PCES)	<input type="text" value="\$80,536,540"/>
Base #2	<input type="text" value="\$0"/>
Enter Const CE Cost >	<input type="text" value="\$0"/>
CE (12.5%)	<input type="text" value="\$10,067,067"/>
Estimate (2016)	<input type="text" value="\$90,603,607"/>

Signals, ITS, Signs and Lighting Costs*	<input type="text" value="\$2,046,849"/>
Cost of Large Drainage Structures	<input type="text" value="\$0"/>
In-Plan Utility Costs*	<input type="text" value="\$0"/>
Adjustment for Unusual Construction Costs	<input type="text" value="\$70,719,008"/>

*\* Totals include district factor calculations*

Additional (or Unusual) P. E. Costs	<input type="text"/>	
Select % of PE to be performed by Consultants	<input type="text" value="30%"/>	PE Cost (PCES) <input type="text" value="\$8,335,532"/>



**Note: Do Not Include Bridge P. E. Costs Here**

Roadway P. E. / Roadway Const. = 9.2%

© Virginia Department of Transportation 2005  
Revised 01/21/16

**Today's Date: 07/11/16**

**Version 6.00**

 **Project Cost Estimating System**   
**Miscellaneous Cost Estimates**

**COST OF LARGE DRAINAGE STRUCTURES**

Job#	Description	Cost ()
<input type="text"/>	<input type="text"/>	<input type="text"/>
<input type="text"/>	<input type="text"/>	<input type="text"/>
<input type="text"/>	<input type="text"/>	<input type="text"/>
<input type="text"/>	<input type="text"/>	<input type="text"/>
<input type="text"/>	<input type="text"/>	<input type="text"/>
		<b>\$0</b>

**ADJUSTMENT FOR UNUSUAL CONSTRUCTION COSTS**

Type	Description	Cost ()
Maintenance of Traffic	20% of roadway costs for MOT	\$8,779,560
Other	5% of roadway and structures costs for landscaping	\$2,801,890
Other	Resurfacing existing roadways	\$3,880,314
Other	Excessive excavation	\$0
Other	Excessive borrow	\$0
Other	Concrete barrier	\$258,437
Other	Guardrail and end treatments	\$148,868
Other	Removal of existing guardrail	\$52,790
Other	Demolition of existing pavement	\$54,751
Other	Noise barriers	\$7,437,117
Other	Retaining walls	\$0
Other	Tunnel costs	\$0
Other	Major in-plan utility work (water and sanitary sewer)	\$0
Other	Wet ponds and bioretention facilities	\$3,225,000
Environmental	Wetland and stream impacts	\$103,950
Environmental	Historic and archaeological resources	\$500,000
Other	Crash walls	\$20,465,892
		<input type="text"/>
Other	40% contingency added to base construction cost	\$23,010,440
		<b>\$70,719,008</b>

Version 6.00

**SIGNALS, ITS, SIGNS and LIGHTING COST WORKSHEET**

Stand Alone Traffic Project:  No

UPC: 106724

**SIGNALS**

Permanent Signals	New/Mod.	Intersection Type	Major				Cross				Poles	Detection	Pre-emption	Cost
			Direction	Lanes	Direction	Lanes	Direction	Lanes	Direction	Lanes				
Location/Description														
1														\$0
2														\$0
3														\$0
4														\$0
5														\$0
6														\$0
7														\$0
8														\$0
9														\$0
10														\$0

Temporary Signals - New Equipment	Quantity	Cost
Temporary Signals - Modified Equipment		\$0

MISCELLANEOUS SIGNAL WORK	Location/Description	Cost
1		
2		

Signals Construction Subtotal \$0

**ITS**

ITS WORK	Location/Description	Cost
1		
2		

ITS Construction Subtotal \$0

**MAJOR SIGN STRUCTURES**

Type of Sign	Comment	Quantity	Unit	Lighted Y/N	Included in Roadway Lighting? yes/no	Cost/Sign	Extended Cost
1	O/H Span (50-100)	1	Ea.	No		112,819	\$112,819
2	Cantilever	2	Ea.	No		56,409	\$112,819
3	Cantilever	4	Ea.	Yes		57,909	\$231,637
4			Ea.				
5			Ea.				
6			Ea.				
7			Ea.				

MISCELLANEOUS SIGN WORK	Location/Description	Cost
1	Add mile post markers at \$1,000/mile for 2.54 miles	\$2,540
2		

Signs Construction Subtotal \$459,815

**LIGHTING**

Continuous Roadway		Urban Type of Lighting	Comments	No. Lanes	Number of Miles	Cost
1						\$0
Freeway		Type of Lighting	Comments	No. Lanes	Number of Miles	Cost
1		Conventional		6	2.54	\$1,400,957
Interchange		Interchange Type	Type of Lighting		Number of Interchanges	Cost
1						\$0
2						\$0
3						\$0
Miscellaneous		Location/Description				Cost
1						
2						

Lighting Construction Subtotal \$1,400,957

**CONSTRUCTION TOTAL \$1,860,772**

*District factor will be applied when the total cost is passed to the const-1 worksheet*

**PROJECT COMMENTS**

Prepared by: CMS

Date Prepared/Modified: 05/05/16

Version 6.00

# BRIDGE CONSTRUCTION AND PRELIMINARY ENGINEERING COSTS

BRIDGE  
CONSTRUCTION

BRIDGE  
P. E.

Bridge Job #

Federal Structure ID

Manual CEI Cost Override :

Bridge # 1 CEI Cost :

11%

Manual PE Cost Adjustment :

Bridge #1 CN + CEI Cost :

P.E. Bridge # 1

BRIDGE #1 CN Cost : (input from Bridge PCES worksheet)

Comments - Constr. Engr. Br. #1:

Comments - Misc. P.E. Bridge #1:

Bridge Job #

Federal Structure ID

Manual CEI Cost Override :

Bridge # 2 CEI Cost :

11.3%

Manual PE Cost Adjustment :

Bridge #2 CN + CEI Cost :

P.E. Bridge # 2

BRIDGE #2 CN Cost : (input from Bridge PCES worksheet)

Comments - Constr. Engr. Br. #2:

Comments - Misc. P.E. Bridge #2:

Bridge Job #

Federal Structure ID





BRIDGE CONSTRUCTION AND PE COSTS (continued)

*Bike / PED Construction Cost* \$0  
*Bike / PED CE* \$0  
*Bike / PED PE* \$0

*Bridge Construction Base (PCES)* \$12,140,000  
*Bridge Removal* \$0  
*Bridge CE (PCES)* \$1,349,625  
**Bridge Estimate. (2016)** **\$13,489,625**  
**Total Bridge P. E. Costs (PCES)** **\$624,189**

**NOTE : Structure Complexity is based upon Height,  
 Difficulty of Construction, and other Factors**

Version 6.00

 <b>Project Cost Estimating System</b> <b>COMMENTS</b> 		
<b>General / Miscellaneous Comments from CONST, RW, &amp; UTILITY Worksheets</b>	<b>Team Member and Section</b>	<b>Date Entered</b>
<b>1</b> Project terrain changed from rolling to level based on comments from L&D on draft cost estimate	C. Sutkowski - HRCS Team	06/23/16
<b>2</b> Moved 10% of roadway and structures costs for general utility relocation from CONST-MISC sheet to MANUAL sheet	C. Sutkowski - HRCS Team	06/27/16
<b>3</b> Input revised bridge costs based on comments from S&B on draft cost estimate	C. Sutkowski - HRCS Team	06/28/16
<b>4</b> Included costs for proposed noise barriers with greater heights than existing (DC and DD) in segment estimate as provided by noise	C. Sutkowski - HRCS Team	06/29/16
<b>5</b> Eliminated costs for right-of-way in MANUAL sheet due to widening in the median	C. Sutkowski - HRCS Team	06/29/16
<b>6</b> Added costs for right-of-way for stormwater management in MANUAL sheet	C. Sutkowski - HRCS Team	06/29/16
<b>7</b> Eliminated cost for culvert extension due to widening in the median	C. Sutkowski - HRCS Team	06/29/16
<b>8</b> Added costs for crash walls along railroad in CONST-MISC tab, assuming a cost of \$850/LF for walls that are 6' high and 2.5' thick	C. Sutkowski - HRCS Team	06/30/16
<b>9</b> Eliminated costs for guardrail due to widening in the median	C. Sutkowski - HRCS Team	06/30/16
<b>10</b>		
<b>11</b>		
<b>12</b>		
<b>13</b>		
<b>14</b>		
<b>15</b>		

**VDOT Project Cost Estimating System  
MANUAL ESTIMATE**

	DATE	PE	RW	CN
<b>EXPENDITURES</b>	01/20/16	\$839,552		\$0
<b>RUMS</b>	01/28/16			\$0
<b>TRNS*PORT</b>				\$0
<b>AWARD</b>	01/28/16			\$0
<b>PROJECTION</b>	01/28/16			\$0

**ESTIMATE YEAR**

**AD YEAR**

FY2016		FY2016
\$0	PE	\$0
\$6,354,718	RW	\$6,354,718
\$0	CN	\$0
\$6,354,718	<b>TOTAL</b>	\$6,354,718

Job #	Phase	Comment	Estimate
<input type="text"/>	<input type="text" value="RW"/>	10% of roadway and structures costs for general utility relocation	<input type="text" value="\$5,603,780"/>
<input type="text"/>	<input type="text" value="RW"/>	Cost for utility work under RW project. See file Utilities Cost Estimate All Segments(AWP).xls	<input type="text" value="\$243,420"/>
<input type="text"/>	<input type="text" value="RW"/>	Cost for Right-of-Way. See file HRCS ROW Costs.xlsx	<input type="text" value="\$0"/>
<input type="text"/>	<input type="text" value="RW"/>	Cost for Right-of-Way for Stormwater Management. See file HRCS ROW Costs.xlsx	<input type="text" value="\$507,518"/>
<input type="text"/>	<input type="text"/>		<input type="text"/>
<input type="text"/>	<input type="text"/>		<input type="text"/>
<input type="text"/>	<input type="text"/>		<input type="text"/>

Job #	Phase	Comment	Estimate
-------	-------	---------	----------

**APPENDIX D:**  
**3-4-3 ANALYSIS**

# Technical Memorandum

**Subject:** Hampton Roads Bridge Tunnel: 3 – 4 – 3 Assessment

## EXECUTIVE SUMMARY

**Introduction:** On November 19, 2015, the Hampton Roads Transportation Planning Organization (TPO) received a presentation on potential capacity improvements that could be made to the Hampton Roads Bridge Tunnel (HRBT). The presentation was aimed at finding capacity improvements that could be realized while confining improvements along the corridor largely within existing right of way. The concepts included a 3 – 3 – 3 Concept, a 3 – X – 3 Concept, and a 3 – 4 – 3 Concept. The numbering associated with each concept refers to the number of lanes approaching the tunnel on land, the number of lanes on the bridges/within the tunnel, and the number of lanes on land. The purpose of this assessment is to perform a conceptual evaluation of the 3 – 4 – 3 Concept from a conceptual design, traffic operations, and safety perspective to inform the Supplemental Environmental Impact Statement (SEIS) based on available data currently under consideration as part of the Hampton Roads Crossing Study (HRCS). An assessment of the 3 – 3 – 3 Concept is included in the SEIS as Alternative A. This memorandum is not intended to provide a comparison to the 3 – 3 – 3 Concept but rather to perform an independent evaluation of the 3 – 4 – 3 Concept.

**Conceptual Design of the 3 – 4 – 3 Concept:** The *Hampton Roads Bridge Tunnel Concept Scenarios* presentation depicts the construction of a new tunnel (3 – 3 – 3 and 3 – X – 3 Concepts) or two new tunnels (3 – 4 – 3 Concept) between the existing I-64 HRBT eastbound and westbound tunnels. Based on a review of the design of the existing HRBT tunnels, VDOT does not want to pursue the construction of a new tunnel between the existing tunnels as originally presented to the TPO due to the risk to the existing tunnels that such construction would pose. Therefore, both this technical memorandum and the HRCS SEIS consider the placement of a new tunnel approximately 200 feet southwest of the existing eastbound tunnel. A conceptual sketch of the 3 – 4 – 3 Concept considered as part of this assessment is shown below in Figure ES-1.

**Figure ES-1: 3 – 4 – 3 Concept Design**

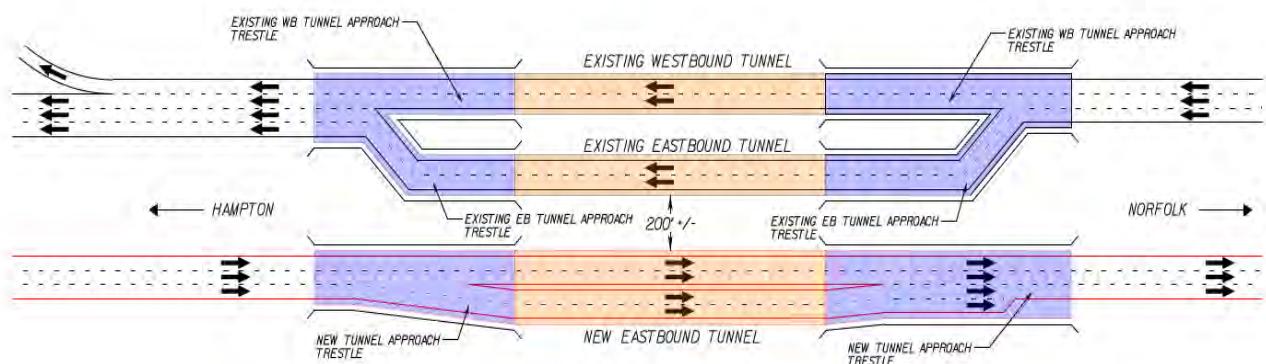

The fundamental geometric issue for the 3 – 4 – 3 Concept is how to widen/diverge I-64 from three lanes to four lanes, and then subsequently, how to merge the four lanes going through the tunnels back down to three lanes before reaching the land side. For the diverge condition, widening the center lane from one lane to two lanes resulting in a “major fork” was considered as part of this assessment in order

---

to minimize the amount of lane changing required to spread traffic evenly over all four lanes through the tunnel. For the merge condition, a right-hand lane merge was considered as part of this assessment in lieu of a center lane merge due to driver expectation concerns.

With the exception of the additional tunnel and bridge lane that would be constructed with the 3 – 4 – 3 Concept, impacts associated with the 3 – 4 – 3 Concept would be similar to the 3 – 3 – 3 Concept (Alternative A of the Draft SEIS). The 3 – 4 – 3 Concept would result in a commensurate increase to the environmental impacts calculated for Alternative A due to the additional tunnel and bridge width. The 3 – 4 – 3 Concept would result in a 15 to 20 increase to the tunnel cost compared to the tunnel costs identified in the Draft SEIS for Alternative A.

Although the 3 – 4 – 3 Concept is not included as a formal alternative in the draft SEIS, it could be incorporated into any alternative that includes improvements to the I-64 Study Area Corridor if there is a desire to assess the need for increased capacity of the HRBT compared to the approach roadways. Additionally, if the 3 – 4 – 3 Concept is identified as part of the preferred alternative, it would be analyzed in greater detail in the Final SEIS, including an assessment of cost and impacts.

**Traffic Operations of the 3 – 4 – 3 Concept:** To assess the operations of the 3 – 4 – 3 Concept under future traffic conditions, four key variables were identified:

- Capacity of the tunnels ranging from 1,675 vehicles per hour per lane (vphpl) to 1,875 vphpl
- Capacity of the on-land roadway and bridge approaches to the tunnels ranging from 1,900 vphpl to 2,100 vphpl
- Traffic demand on the approaches to the tunnels under future conditions ranging from 1,660 vphpl (based on the HRCS SEIS year 2040 forecasts) to 2,100 vphpl
- Per lane traffic distribution (utilization or split) between the two-lane tunnels by direction – “even distribution” versus “left-hand-lane bias”

To analyze these four key variables in combination with each other and to help visualize the resulting traffic flows under the 3 – 4 – 3 Concept, sixteen scenarios were considered to assess how a given traffic demand would flow through the choice lane diverge, experience capacity loss in the tunnel, and then merge downstream. The scenarios are discussed in more detail in Section 4.5.

Although there were relatively small ranges in the analyzed “per-lane” capacities and approach demand, comparing different combinations of these key variables yielded very different scenarios. For example, in Figure ES-2, all four lanes of traffic within the tunnel would operate below capacity with evenly-distributed volumes; however, the required downstream merging would result in extreme turbulence across all lanes as thousands of vehicles per hour are forced to change lanes to accommodate merging traffic from right-to-left. In Figure ES-3, lane choices are exaggerated such that all traffic stays as far left as possible to avoid the downstream merging conflicts departing the tunnels. However, capacities in this exaggerated lane utilization scenario nearly accommodate all of the tunnel traffic within three lanes; thus, minimizing the need for a fourth tunnel lane.

**Figure ES-2: Traffic Flow Schematic (Scenario 12)**

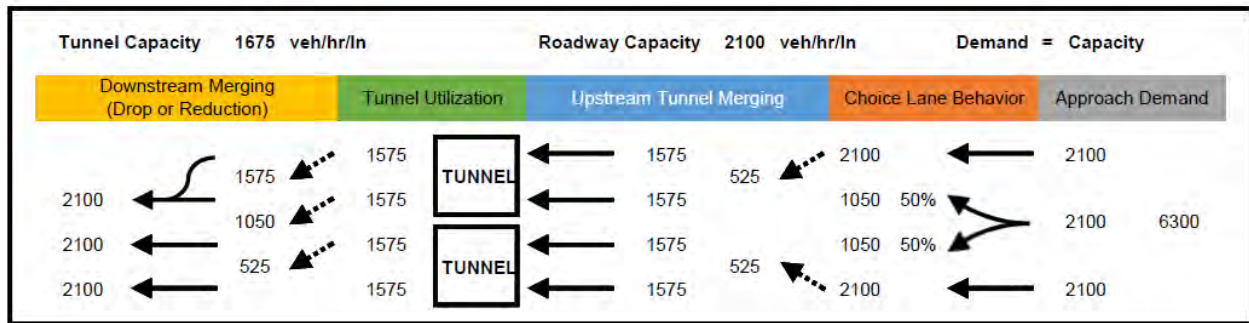

**Figure ES-3: Traffic Flow Schematic (Scenario 6)**

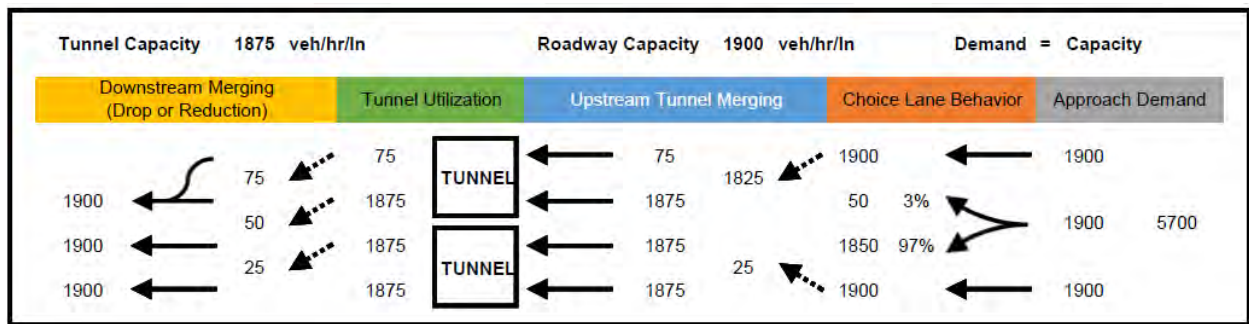

A speed-flow diagram for the eastbound I-64 tunnel entrance was utilized to predict planning-level anticipated vehicular speeds associated with the downstream merging maneuvers. If the downstream lane reduction merging volumes are high (see Figure ES-2) and, consequently, there is a lot of turbulence and friction as motorists depart the tunnel and abruptly work their way from right-to-left across the roadway, then the downstream travel speed will likely decrease significantly due to individual lanes temporarily exceeding capacity. In this instance, the resulting deceleration “shockwave” will be very severe and it will travel upstream through the initially uncongested tunnel lanes. Further, motorists within the tunnel will likely be exposed to a rather noticeable “accordion effect,” including very abrupt braking, which has significant safety implications especially within a confined roadway segment such as a tunnel.

This planning-level assessment provides an approximation of the anticipated speeds based on assumptions regarding the ability for motorists to merge at the downstream end of the tunnel. The exact amount of lane changing that can be accommodated without significantly degrading traffic operations is unknown. However, it can be reasonably assumed that the calculated number of lane changes assuming even distribution of traffic between the tunnel lanes will significantly degrade operations at the downstream end of the tunnels with the 3 – 4 – 3 Concept.

It should be noted that when a travel lane is added along a facility, motorists have a natural tendency to utilize available (unoccupied) lane capacity especially in high-volume corridors approaching at-capacity conditions such as the I-64 corridor during peak periods. Based on the combination of scenarios considered (see Section 4.5), all “even distribution” scenarios result in severe congestion due to the downstream lane reduction beyond the tunnel. Another conclusion that can be drawn is that five of the eight “left-hand-lane bias” scenarios considered result in less than a 5-percent utilization of the fourth tunnel lane. As noted above, motorists will likely have a natural tendency to attempt to utilize the fourth lane; however, these five scenarios illustrate that a fourth tunnel lane is minimally justified to accommodate anticipated approach traffic demand.

---

Only two of the scenarios considered have reasonable usage of the fourth tunnel lane (i.e., greater than 5 percent) while also resulting in mild or unchanged congestion levels. However, these two scenarios reflect the exaggerated “left-hand-lane bias” tunnel utilization, which are unlikely to be realized under “real-world” conditions due to motorists’ natural tendency to utilize available lane capacity (i.e., the fourth tunnel lane). Consequently, these two exaggerated scenarios will effectively regress (converge) to “even distribution” scenarios, which have severely degraded anticipated congestion levels due to extensive downstream merging and lane changing maneuvers.

**Safety of the 3 – 4 – 3 Concept:** Higher crash rates along freeway facilities typically occur at locations where drivers must make a choice and/or perform a driving maneuver (as opposed to continuing along the through traveled way). Merges and diverges are two examples of these locations which tend to experience higher crash frequencies. The 3 – 4 – 3 Concept introduces a major diverge (major fork) on the approach to the tunnel and a major merge point (branch connection) beyond the tunnel exit. Therefore, it can be presumed that this design could potentially result in more crashes than a design with a continuous cross section without merge and diverge points.

**3 – X – 3 Concept:** This scenario includes a new two-lane tunnel with two reversible lanes depending on the time of day with four lanes in the peak direction and two lanes in the off-peak direction. Reversible lane systems are typically considered along facilities with significant directionality during peak periods in order to maximize traffic capacity in the peak direction of travel while maintaining acceptable operations in the non-peak travel direction. Based on a review of existing and forecasted traffic volumes, peak hour traffic volumes on the eastbound and westbound approaches to the HRBT are relatively similar.

The travel direction with four lanes would operate similar to the 3 – 4 – 3 Concept with both operational and safety issues associated with the merge and diverge junctions at the transition from three lanes to four lanes and then back down to three lanes. The non-peak or unfavored travel direction would effectively operate as a 3 – 2 – 3 configuration with three approach lanes merging down to two tunnel lanes. Based on the equal distribution of traffic between the eastbound and westbound tunnels, a reversible lane system is not appropriate to accommodate the similar traffic volumes in both directions and the merge from three lanes to two lanes in the unfavored travel direction would result in a bottleneck causing significant delays during peak periods.



---

## 1. INTRODUCTION

### 1.1 STUDY PURPOSE

On November 19, 2015, the Hampton Roads Transportation Planning Organization (TPO) received a presentation on potential capacity improvements that could be made to the Hampton Roads Bridge Tunnel (HRBT).<sup>1</sup> The presentation was aimed at finding capacity improvements that could be realized while achieving the commitment made by the Federal Highway Administration (FHWA) and the Virginia Department of Transportation (VDOT) to confine improvements along the corridor largely within existing right of way. The concepts included a 3 – 3 – 3 Concept, a 3 – X – 3 Concept, and a 3 – 4 – 3 Concept referring to the number of lanes approaching the tunnel on land, the number of lanes on the bridges/within the tunnel, and the number of lanes on land downstream of the bridge/tunnel. Specifically, these concepts included widening the existing four-lane I-64 facility from four lanes to six lanes with limits similar to what is proposed as part of Alternatives A, B, and D and with a varying number of lanes and configuring the HRBT as follows:

- 3 – 3 – 3 Concept: Includes a new two-lane tunnel to create six total tunnel lanes (3 per direction) with the middle tunnel serving two-way traffic. The number of tunnel lanes with this alternative is the same as Alternatives A, B, and D although the configuration of the tunnels differs. This concept is documented in the Supplemental Environmental Impact Statement (SEIS) as Alternative A.
- 3 – X – 3 Concept: Includes a new two-lane tunnel with two reversible lanes depending on the time of day (four lanes in the peak direction; two lanes in the off-peak direction).
- 3 – 4 – 3 Concept: Includes four new tunnel lanes to create eight total tunnel lanes (4 per direction). The intent of this concept is that because the HRBT tunnels have, or are perceived to have, a lower capacity than the roadway and trestle sections on the approaches to the tunnels, the overall capacity of the crossing might be improved if the capacity at the bottleneck (i.e., the tunnels) is improved.

The configurations of these concepts are presented schematically in Section 3 of this memo.

The purpose of this assessment is to perform a conceptual evaluation of the 3 – 4 – 3 Concept from a conceptual design, traffic operations, and safety perspective to inform the SEIS. The 3 – X – 3 Concept also is discussed in relation to the 3 – 4 – 3 Concept as well as the implications of a potential managed lanes scenario. An assessment of the 3 – 3 – 3 Concept is included in the SEIS as Alternative A. This memorandum is not intended to provide a comparison to the 3 – 3 – 3 Concept but rather to perform an independent evaluation of the 3 – 4 – 3 Concept.

The traffic operational assessment is based on available existing traffic volume data and traffic forecasts for the Alternatives currently under consideration as part of the Hampton Roads Crossing Study (HRCS). Based on the conceptual nature of the 3 – 4 – 3 Concept, information is not available to perform a detailed traffic operational analysis or microsimulation of the 3 – 4 – 3 Concept. This type of analysis would require traffic forecasts specific to the 3 – 4 – 3 Concept, calibration of an existing conditions microsimulation model based on field conditions, and details regarding the specific geometric and traffic operational features of the 3 – 4 – 3 Concept (e.g., downstream destinations affecting lane choice, lane

---

<sup>1</sup> “Hampton Roads Bridge Tunnel Concept Scenarios.” Hampton Roads Transportation Planning Organization. November 19, 2015, accessed March 30, 2016, <http://www.hrtpo.org/uploads/docs/111915TPO-Presentation%2013-HRBT%20Concept%20Scenarios.pdf>

---

and shoulder widths, vertical clearance, grades, proximity and configuration of adjacent ramp terminals/junctions, etc.) that are unavailable at this time.

However, forecasts for Alternative A (3 – 3 – 3 Concept) from the SEIS are considered in the evaluation of the 3 – 4 – 3 Concept which reflect the widening of I-64 from four lanes to six lanes from the I-64/I-664 interchange in Hampton to the I-564 interchange in Norfolk which is appropriate given the conceptual nature of this evaluation of the 3 – 4 – 3 Concept.

## **2. DATA REVIEW**

### **2.1 EXISTING TRAFFIC DATA**

Existing traffic volume and speed data were obtained for various locations on the approach and departure sides of the tunnel via a network of in-roadway vehicle detectors and pole-mounted vehicle data recorders. The data was obtained for calendar year 2015, typically in 15-minute intervals. One of the objectives of the existing traffic data analysis was to determine the actual per lane capacities of the tunnels and adjoining “on-land” roadway and bridge approaches. Because traffic demand regularly reaches and exceeds capacity in this area, the peak recorded volumes at the data collection locations should reflect existing capacity unless the demand is “metered” farther upstream of the count stations. The 99<sup>th</sup>-percentile 15-minute volume was determined throughout the day for each count location considering Tuesday, Wednesday, and Thursday traffic volumes, and a peak hourly volume of four consecutive 15-minute intervals was obtained.

Figure 1 depicts the count locations and the corresponding observed peak hourly traffic volumes.

**Figure 1: Volume and Speed Data Locations and Peak Hourly Volumes**



## 2.2 HRCS SEIS TRAFFIC PROJECTIONS

Year 2040 traffic forecasts for the No Build Alternative and HRCS Alternatives A, B, C, and D are presented in Table 1. The development of these forecasts is documented in the HRCS SEIS *Traffic and Transportation Technical Report*. Based on the forecasts, the highest predicted traffic volumes correspond to Alternative A with a peak hourly volume of 4,975 in the eastbound direction during the AM peak hour and 4,970 in the westbound direction during the PM peak hour. These highest forecasted peak hour traffic volumes were considered as part of this assessment because the 3 – 4 – 3 Concept will include one additional tunnel lane per direction compared to the HRCS alternatives that add additional capacity along the I-64 corridor. Additionally, the forecasts for Alternative A most closely match the configuration of the 3 – 4 – 3 Concept.

**Table 1: HRCS Existing and Future Traffic Volume Forecasts**

Year / Scenario	Weekday Daily Traffic Volume	Weekday AM (PM) Peak Hour Volume	
		Eastbound	Westbound
2015 (Existing)	91,000	3,440 (3,445)	3,370 (3,155)
2040 No Build	122,200	4,175 (4,285)	4,250 (3,915)
2040 Alt A	137,700	4,975 (4,710)	4,815 (4,970)
2040 Alt B	133,400	4,765 (4,865)	4,690 (4,485)
2040 Alt C	103,600	3,635 (3,575)	3,605 (3,630)
2040 Alt D	124,200	4,255 (4,200)	4,315 (4,475)

### 2.3 TPO CONCEPTS ASSUMED CAPACITIES

As depicted by the TPO in the *Hampton Roads Bridge Tunnel Concept Scenarios* presentation and as further discussed below, there are two capacity values relevant to determining the potential operation of the 3 – 4 – 3 Concept and utilization of a fourth tunnel lane. A discussion of calculated values specifically utilized in this study is discussed in Section 4.

**Tunnel Capacity:** Previous analysis of the 3 – 4 – 3 Concept by the TPO that was depicted in the *Hampton Roads Bridge Tunnel Concept Scenarios* presentation noted the capacity of the HRBT (existing and future) as 1,600 vehicles per hour per lane (vphpl). This capacity was obtained by reviewing hourly volumes from 4 PM to 5 PM during calendar year 2012 (359 days of available data). The capacity per lane was calculated by identifying the mode of that data as 3,250 vehicles per hour (vph) or 1,625 vphpl, which was then rounded down to 1,600 vphpl.

For this assessment, it was assumed that the theoretical capacity of the tunnel is the highest hourly volume that can travel through the tunnel based on 2015 traffic data. Thus, the 99<sup>th</sup>-percentile 15-minute volume was determined throughout the day for each location considering Tuesday, Wednesday, and Thursday traffic volumes, and a peak hourly volume of four consecutive 15-minute intervals was obtained. Using these metrics, the tunnel capacity is likely higher than 1,600 vphpl resulting in less of a differential between the tunnel capacity and the capacity of the on-land approaches to the tunnel than was assumed in the in the *Hampton Roads Bridge Tunnel Concept Scenarios* presentation. The calculated and assumed values for this assessment are discussed in more detail in Section 4.1.

**Capacity of the On-Land Approaches to the Tunnel:** The TPO’s assumed capacity of the on-land approaches to the tunnels, as depicted in the *Hampton Roads Bridge Tunnel Concept Scenarios* presentation, is 2,100 vphpl. The primary basis for this assumption is that the upper boundary in the *Highway Capacity Manual (HCM)* for a basic freeway segment capacity is 2,400 vphpl. The assumed value for the capacity of the on-land approaches to the tunnels establishes the amount of traffic that can reach the tunnels and therefore significantly influences the need for additional tunnel lanes to adequately serve the approach traffic volumes. The assumed values for this assessment are discussed in more detail in Section 4.2.

---

### **3. CONCEPT DESIGN FOR 3 – 4 – 3 ASSESSMENT AND DISCUSSION OF IMPACTS**

As previously noted, the basis for this assessment is the *Hampton Roads Bridge Tunnel Concept Scenarios* presentation. The presentation depicts the construction of a new tunnel (3 – 3 – 3 and 3 – X – 3 Concepts) or two new tunnels (3 – 4 – 3 Concept) between the existing I-64 HRBT eastbound and westbound tunnels. Based on a review of the design of the existing HRBT tunnels, VDOT does not want to pursue the construction of a new tunnel between the existing tunnels due to the risk to the existing tunnels that such construction would pose. Therefore, the HRCS SEIS considers the potential construction of a new tunnel approximately 200 feet southwest of the existing eastbound tunnel. Conceptual sketches analogous to those in the TPO presentation are shown in Figure 2.

The geometry developed for this assessment was based on three primary sources:

- Aerial mapping showing existing lane configurations, bridges/structures, waterways, etc.
- Right of way, municipal boundaries, and existing contours originating from GIS sources
- A six-lane roadway section along I-64 from Mallory Street (Exit 268) to 13<sup>th</sup> View Street (just west of the bridge over Willoughby Bay) as shown in the HRCS SEIS *Alternatives Technical Report*

For the new eastbound tunnel, the following was assumed:

- The design speed will be 70 mph
- Grades into and out of the tunnel will match the existing grades (i.e., four percent) which are marginally acceptable per Footnote *a* of Table 8-1 in the Green Book, as grades are normally limited to three percent for a 70-mph design speed in level terrain. Limiting the grades to three percent would result in a longer tunnel.
- The existing islands at either end of the tunnel will be widened to the southwest to accommodate the new tunnel
- Although a profile was not developed as part of this assessment, the trestle sections at either end of the tunnel will be designed approximately eight feet higher than the existing trestle sections in order to account for potential sea-level rise and storm surges. Grades should therefore match existing I-64 grades about 500 feet east and west of the existing bridge ends in Hampton and on Willoughby Spit.
- The diverge (from three to four lanes) and merge (from four lanes back to three) will take place over the water in order to minimize right of way impacts. For the existing tubes, which will become the future westbound tubes, the diverge and merge are assumed to take place on land in order to minimize reconstruction and/or widening of the existing bridge sections.

It should be noted that this assessment does not address to rehabilitation and/or reconstruction of existing facilities that would be required in conjunction with the 3 – 4 – 3 Concept. If this concept is carried forward for more detailed studies, those issues would be considered as part of the additional detailed studies.

**Figure 2: Conceptual Layout of Tunnel Configurations**

**3 – 3 – 3 Concept**

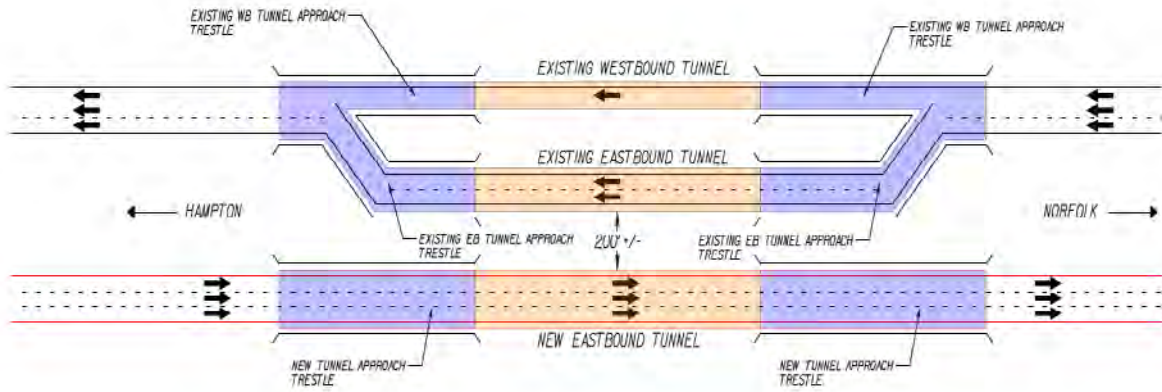

**3 – X – 3 Concept**

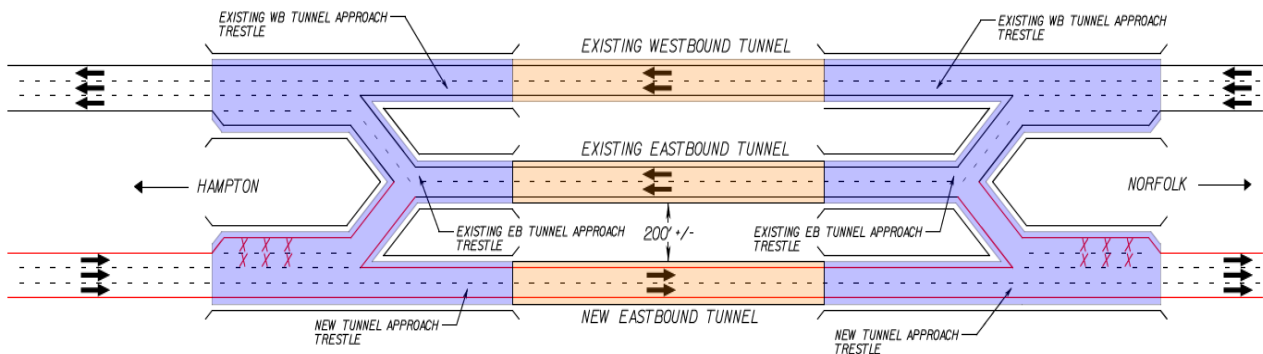

**3 – 4 – 3 Concept**

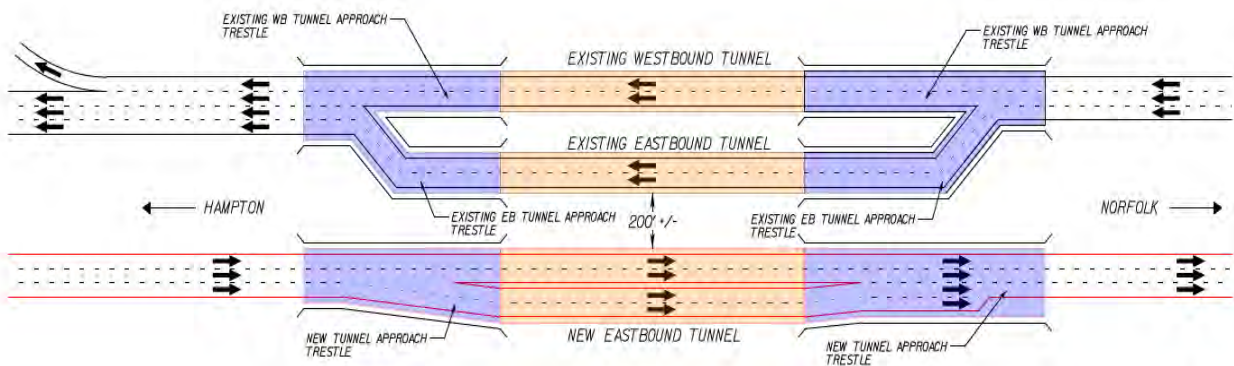

Attachment A contains four drawings that depict the conceptual design for the 3 – 4 – 3 Concept. It should be noted that both of the existing tunnels/approach roadways include geometric deficiencies that do not provide a 70-mph design speed when compared to current standards. For example, the I-64 eastbound horizontal curve after exiting the tunnel has a radius under 1,500 feet, which could provide a design speed of approximately 65 mph (per VDOT standard TC-5.11), depending on the superelevation (existing cross slopes have not been assessed). Of more concern is the crest vertical curve entering the I-64 westbound tunnel, which, according to the original plans has a K-value of only 88, which corresponds to a design speed of 50 mph (per Table 3-34 in AASHTO’s 2011 Green Book). This may be a contributing

---

factor to lower observed tunnel volumes on the westbound approach compared to the eastbound approach. The sag vertical curves in the westbound tunnel have even lower design speeds, the lowest (K-value of 44) being on the sag preceding the four-percent grade out of the tunnel, which corresponds to a design speed of only 30 mph (per Table 3-36 in the Green Book). It should be noted that the tunnel lighting may partially mitigate the detrimental effects of the low design speeds.

Both the 3 – 4 – 3 Concept and the 3 – 3 – 3 Concept convert the existing eastbound bridge-tunnel to a westbound operation. Without modifications, the wider shoulder will be located on the left rather than on the right side of the travel lanes and the crown line between the two existing lanes will be improperly located for westbound travel. Therefore, it is assumed that in both scenarios, roadway improvements will be made to ensure the crown is properly located and appropriate shoulder widths are provided.

The fundamental geometric issue for the 3 – 4 – 3 Concept is how to widen/diverge I-64 from three lanes to four lanes, and then subsequently, how to merge the four lanes going through the tunnels back down to three lanes. Figure 3 presents three options for accomplishing the diverge and subsequent merge.

**Diverge Configuration:** The most applicable guidance for the diverge condition is found in Section 10.9.6 of the Green Book. By developing the diverge areas in both directions along I-64 as “major forks” (per Figure 10-75B of the Green Book), with the center lane (of three lanes) being widened from 12 feet to 24 feet over a distance of 1,000 feet, drivers in the center lane (of three lanes) on I-64 may choose to use either tube without any lane changing required (see Options B and C). Drivers in either the inside or outside lane (of three lanes) on I-64 would have to change a maximum of one lane in order to use the “other” tube and to evenly spread traffic over all four lanes through the tunnel. If a lane were added on either the left or right of the three-lane section (see Option A), more lane changing would be required in order to achieve balanced lane usage through the tunnels. Therefore, widening the center lane to two lanes was considered as part of this assessment.

**Merge Configuration:** Similarly, the merge area at the downstream end along I-64 eastbound is treated as a “branch connection” (per Figure 10-76 of the Green Book). Consistent with driver expectation and guidance contained in the Green Book, the right lane of four is eliminated in order to reduce I-64 eastbound back to three lanes (see Options A and B). This merge occurs on the tangent portion of the trestle section just before the horizontal curve to the left approaching Willoughby Spit. In the current configuration for I-64 westbound, the right lane of four is dropped at the loop ramp exit to Mallory Street (see Figure 2). Assuming adequate advance signing along Willoughby Spit and across Willoughby Bay advising drivers destined to exit at Mallory Street to use the right two lanes, this configuration may prove to be operationally acceptable. However, detailed traffic modeling during final design would need to be performed to verify this operational acceptability.

For the new eastbound tunnel, the middle two lanes could be merged back together as shown in Figure 3: Option C. Although this configuration is documented in the Green Book, inside lane merges are infrequently constructed due to driver expectation concerns and the greater potential for crashes involving inside lane merges. Because of the potential safety concerns associated with an inside lane merge (Option C), a right lane merge was considered as part of this assessment.

In summary, a major fork connection with the center lane (of three lanes) being widened to two lanes and a branch connection with a right-hand lane merge was considered as part of this assessment as shown in Figure 3: Option B.

**Figure 3: 3 – 4 – 3 Concept Potential Lane Configuration**

***Option A: Add Auxiliary Lane on Right and Merge on Right***

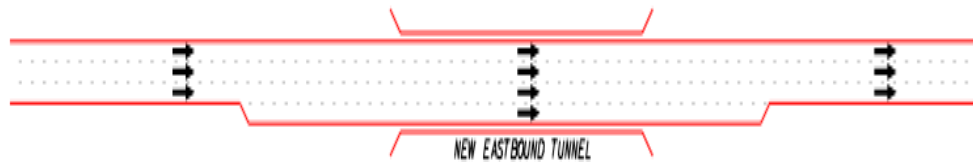

***Option B: Major Fork and Branch Connection (with Right Lane Merge)***



***Option C: Major Fork and Branch Connection (with Center Lane Merge)***



The conceptual sketches developed for this assessment assume the provision of acceleration lanes adequate for a 70-mph mainline design speed and deceleration lanes appropriate for the same mainline speed (per Tables 10-3 and 10-5 respectively in the Green Book). This results in longer lanes than currently exist for the following ramps:

- I-64 eastbound on-ramp from Mallory Street, with the taper ending right at the beginning of the new trestle section
- I-64 eastbound and westbound exit ramps to West Ocean View Avenue/Willoughby Spit. The eastbound taper begins near the east end of the trestle section. The westbound taper begins at the I-64 bridge over 13<sup>th</sup> View Street in order to provide a deceleration lane to the truck inspection station located approximately 300 feet east of the exit to Willoughby Spit.
- I-64 eastbound on-ramp from Bayville Street, which extends almost to the I-64 bridge over 13<sup>th</sup> View Street
- I-64 westbound on-ramp from West Ocean View Avenue, which requires widening of the existing westbound trestle

Because the geometric variations discussed in this memo are located primarily on the bridge or in the tunnel section of the HRBT, right of way impacts are expected to be similar to those from the six-lane section described in the HRCS SEIS Alternatives Technical Report.



---

## 4. TRAFFIC OPERATIONS ASSESSMENT

To assess the operations of the 3 – 4 – 3 Concept under future traffic conditions, four key variables were identified:

- Capacity of the tunnels
- Capacity of the on-land roadway and bridge approaches to the tunnels
- Traffic demand on the approaches to the tunnels under future conditions
- Per lane traffic distribution (utilization or split) between the two-lane tunnels by direction (i.e., the number of motorists using each lane within each tube)

It should be noted that there are many other factors that could contribute to the precise operation of a potential 3 – 4 – 3 Concept, including the final roadway and bridge geometrics on the approaches to, and departures from, each two-lane tunnel and within each tube itself (e.g., downstream destinations affecting lane choice, lane and shoulder widths, vertical clearance, grades, proximity and configuration of adjacent ramp terminals/junctions, etc.). However, the four key variables listed above are the primary constraints on the system's overall performance; therefore, it is critical to gain an understanding of how significant deviations (i.e., ranges) for each of these key variables can affect the qualitative and quantitative benefits of the 3 – 4 – 3 Concept.

### 4.1 MEASURED CAPACITY OF THE TUNNELS

Traffic flow theory refers to the basic principles of the movement and interaction of vehicles and the direct relationship of three core traffic variables – flow (volume), density, and speed. By understanding these fundamental traffic flow variables, specific roadway segments and traffic characteristics can be evaluated without microscopic traffic software packages, which generally include many adjustment factors, assumptions, and potentially a more refined conceptual highway design. Specifically, two particular fundamental traffic flow diagrams (charts) were developed for the empirical analysis of the HRBT traffic operations:

- **Flow (volume) – Density:** A graph depicting measured volumes (vph) at a data collection station and calculated roadway densities (vehicles per mile) will typically illustrate a distinct linear relationship at lower (uncongested) densities prior to reaching a “critical density,” beyond which congestion will occur. Once the “critical density” is exceeded, traffic volumes will sharply decrease as density increases, because adding more vehicles to the roadway segment will consequently increase driver discomfort and turbulence while reducing vehicular speeds.
- **Speed – Flow (volume):** A graph depicting measured speeds (mph) and volumes (vph) at a data collection station will typically illustrate uncongested traffic travelling at a consistent “free-flow” speed until the volume reaches the maximum flow rate (capacity). However, once congestion occurs due to traffic demand exceeding capacity, both vehicular speed and measured traffic volume will decrease significantly.

Traffic volume data with corresponding speed data was available for most of the data collection locations depicted in Figure 1; therefore, the above described relationships were plotted for each travel direction along I-64 to establish the fundamental traffic flow diagrams included in Attachment B. Specifically, data was obtained in 15-minute intervals and then converted to hourly flow rates and plotted on the diagrams. These fundamental flow-density and speed-flow diagrams do not require further “model calibration” because the charts are derived using actual (empirical) HRBT traffic metrics.

---

As shown in Attachment B, the diagrams for eastbound I-64 at the entrance to the HRBT tunnel generally form the customary parabolic shapes that are referenced in the *HCM* and traffic flow theory textbooks. The eastbound tunnel entrance diagrams also illustrate data points for both uncongested (free-flowing) and congested traffic conditions, which likely indicates that the eastbound data collection stations upstream of the tunnel (see Figure 1) are positioned in locations that can accurately measure the eastbound tunnel capacity. This premise is further supported by the eastbound diagrams in Attachment B for the data collection location 2.7 miles downstream of the tunnel, which solely depicts uncongested traffic flow conditions therefore validating that the tunnel is the effective bottleneck in the eastbound direction.

On the contrary, the diagrams for westbound I-64 at the entrance to the HRBT tunnel, as well as the diagrams for count locations farther upstream, display mostly “uncongested” portions of the typical traffic flow curves, especially at the westbound tunnel entrance where the charts illustrate very infrequent data points with reduced speeds or relatively high densities. Further, the collected traffic data suggests that the westbound tunnel may be “metered” farther upstream by an additional traffic constraint, such as the two relatively tight horizontal curves on the roadway/bridge approach to the tunnel and/or the upstream interchanges on the approach to the HRBT. Consequently, there is more uncertainty in the collected westbound traffic data with respect to the actual (i.e., “unmetered”) westbound tunnel capacity.

The measured traffic volume and speed data and the corresponding fundamental traffic flow diagrams indicate that there may be additional influences on the perceived tunnel capacities during congested traffic periods, especially in the westbound direction. As a result, it is more appropriate and conservative to assess the future 3 – 4 – 3 Concept based on the collected range of values for the tunnel capacity as opposed to relying on a definitive single value of 1,600 vphpl for the tunnel capacity, as noted in the *Hampton Roads Bridge Tunnel Concept Scenarios* presentation. Based on the measured peak hour traffic volumes depicted in Figure 1 for the eastbound and westbound tunnel entrances and exits, the minimum observed tunnel “capacity” (throughput) is 3,350 vph and the maximum observed tunnel “capacity” (throughput) is 3,750 vph, which equates to a “per-lane” tunnel capacity range for this assessment of 1,675 vphpl to 1,875 vphpl, respectively.

#### **4.2 CAPACITY OF THE ON-LAND APPROACHES TO THE TUNNEL**

The assumed capacity on the roadway and bridge approaches to the tunnels, as depicted in the *Hampton Roads Bridge Tunnel Concept Scenarios* presentation, is 2,100 vphpl. The primary basis for this prior assumption is that the upper boundary in the *HCM* for a basic freeway segment capacity is 2,400 vphpl.

Based on the measured peak hour traffic volumes depicted in Figure 1, the maximum observed on-land hourly traffic volume approaching the tunnel was recorded at 3,800 vph on eastbound I-64 just east of the entrance from Mallory Street, which equates to a “per-lane” capacity of 1,900 vphpl. Therefore, because specific *HCM* factors and calculations were not applied to generate the assumed approach capacity of 2,100 vphpl for the HRBT, a more conservative range of 1,900 vphpl to 2,100 vphpl was utilized to evaluate the 3 – 4 – 3 Concept.

---

### **4.3 TRAFFIC DEMAND**

Based on a review of the year 2040 traffic forecasts for the HRCS (see Table 1 in Section 2.2), Alternative A reflects the highest volumes at the tunnel given the current HRCS alternatives under consideration. The highest approach volume by direction and by peak for this alternative is 4,975 vph, which equates to about 1,660 vphpl (assuming an equal distribution of traffic across all three Alternative A tunnel lanes).

Given the measured range of capacity values of the tunnels (i.e., 1,675 vphpl to 1,875 vphpl as noted in Section 4.1) compared to the traffic forecasts for the HRCS alternatives (maximum of 1,660 vphpl), it can be reasonably assumed that there would be minimal delays approaching the tunnels with the 3 – 4 – 3 Concept. Therefore, a sensitivity analysis was performed for the traffic demand also equaling two assumed potential approach capacities of 1,900 vphpl and 2,100 vphpl (based on the preceding discussion in Section 4.2), which equate to peak hour demands of 5,700 vph and 6,300 vph, respectively, across all three approach lanes to the tunnels. It is reasonable to consider this higher range of assumed traffic demand for the future 3 – 4 – 3 Concept, because providing capacity improvements frequently results in increased traffic volumes on the improved network (i.e., “latent demand” resulting from some motorists with alternate viable routes currently avoiding the HRBT due to existing or perceived travel delays and then subsequently altering their travel patterns once the HRBT is improved and becomes a more desirable route option).

### **4.4 DISTRIBUTION OF TRAFFIC BETWEEN THE TUNNELS**

Motorists along each approach to the tunnels will have to make a decision regarding which tunnel to travel. This decision will be based on several factors including:

- Ability to access the choice (diverge) lane – Motorists in the middle travel lane on each three-lane approach to the tunnel will have the ability to choose between the two tunnels. However, during congested time periods, motorists in the left-most and right-most lanes may be reluctant or unable to abruptly change lanes in advance of the tunnel diverge if one of the tunnels is perceived by motorists to be less congested. As a result, there may be an imbalance in the lane utilization because some motorists may be prepositioned by upstream traffic conditions, such as on-ramp entries and lane avoidance in the vicinity of off-ramps.
- Downstream lane reduction – On the departure side of each tunnel, the lanes will be reduced to three lanes in each direction along I-64 from right-to-left. Non-aggressive motorists may shy away from the right-most tunnel because of the anticipated merging conflicts originating on the right-hand side of the departure lanes as motorists merge left.
- User equilibrium – For most traffic networks with traditional commuter peak periods, there is a natural tendency for traffic to balance itself out along alternative “routes” (e.g., tunnels in the case of the 3 – 4 – 3 Concept). However, for the HRBT, if there is congestion on the downstream end of a specific tunnel that has not spilled back to the upstream end of the tunnel, motorists are likely unable to make an informed decision about which tunnel to choose. This predicament would become more significant if the future demand approaches the HRBT capacity on a much more frequent basis (e.g., during typical commuting hours). Consequently, motorists may unknowingly and repeatedly select the wrong choice in an attempt to improve their own travel time.

**4.5 ASSESSMENT OF KEY VARIABLES**

To analyze the key variables discussed in Sections 4.1 through 4.4 in combination with each other and to help visualize the resulting traffic flows under the 3 – 4 – 3 Concept, volume schematics were created depicting how a given traffic demand would flow through the choice lane diverge, experience capacity loss in the tunnel, and then merge downstream.

Although there were relatively small ranges in the analyzed lane capacities and approach demand, comparing different combinations of these key variables can yield very different scenarios. For example, in Figure 4, all four lanes of traffic within the tunnel would operate below capacity with evenly-distributed volumes; however, the required downstream merging would result in extreme turbulence across all lanes as thousands of vehicles per hour are forced to change lanes to accommodate merging traffic from right-to-left. In Figure 5, lane choices are exaggerated such that all traffic stays as far left as possible to avoid the downstream merging conflicts departing the tunnels. However, capacities in this exaggerated lane utilization scenario nearly accommodate all of the tunnel traffic within three lanes; thus, minimizing the need for a fourth tunnel lane.

Attachment C contains additional sensitivity analyses for the combinations of the four variables considered for this assessment.

**Figure 4: Traffic Flow Schematic (Scenario 12)**

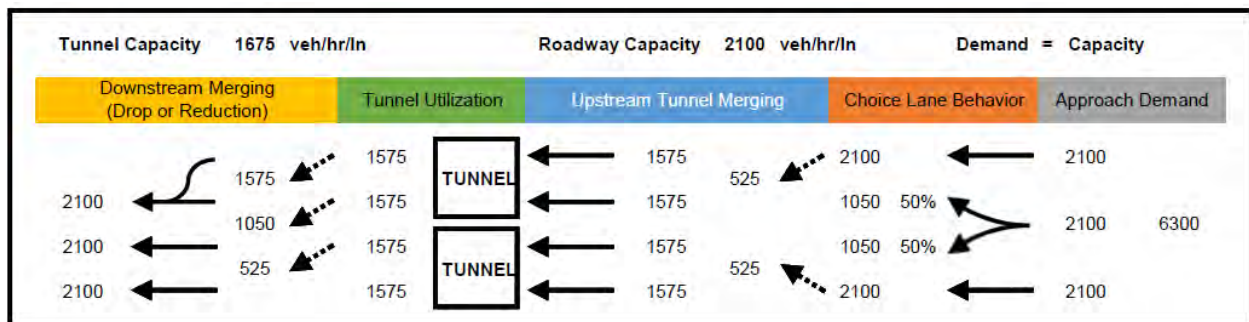

**Figure 5: Traffic Flow Schematic (Scenario 6)**

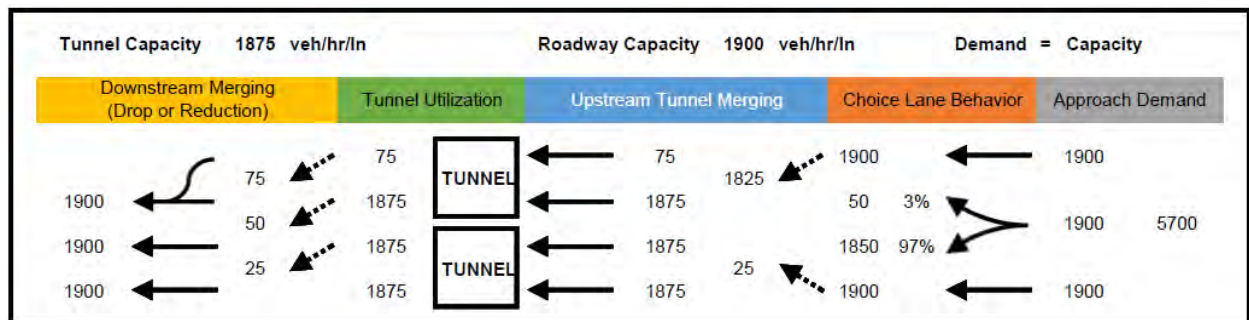

As illustrated in Figure 4 and further depicted in Attachment C, a more balanced choice (diverge) lane scenario could result in a significant impact to traffic operations and safety farther downstream at the tunnel departure lane reduction if the:

- Future HRBT demand is relatively close to the system capacity, or if the
- “Per-lane” on-land roadway capacity significantly exceeds the “per-lane” tunnel capacity, as initially assumed in the *Hampton Roads Bridge Tunnel Concept Scenarios* presentation

In order to quantify the potential impacts associated with merging behaviors at the downstream lane reductions, the site-specific fundamental traffic flow diagrams in Attachment B were again utilized as empirical, planning-level “models” for the future traffic operations. According to the *HCM*, “there are no effective models of performance for a major merge area,” which further supports the importance of understanding the simplified traffic flow theories and relationships among volume, density, and speed. Table 2 summarizes the anticipated planning-level travel speeds and congestion for each combination of the key variables presented in Attachment C. A discussion of the anticipated speeds and congestion levels is provided below.

**Table 2: Summary of Tunnel Lane Utilization and Downstream Merging Impacts by Scenario**

Scenario	Tunnel Lane Utilization	Tunnel Capacity (vphpl)	On-Land Roadway Capacity (vphpl)	Approach Demand (vphpl) <sup>1</sup>	4 <sup>th</sup> Tunnel Lane Utilization <sup>2</sup>	Downstream # of Lane Changes (vph)	Planning-Level Downstream Speed (mph)	Anticipated Congestion Level	Tunnel Capacity ≥ Approach Demand
1	Left-Hand-Lane Bias <sup>3</sup>	1,675	1,900	1,660	0%	0	62	No change	✓
2				1,900	40%	1,350	55	Mild	
3			2,100	1,660	0%	0	62	No change	✓
4				2,100	76%	2,550	23	Severe	
5		1,875	1,900	1,660	0%	0	62	No change	✓
6				1,900	4%	150	62		
7			2,100	1,660	0%	0	62	✓	
8				2,100	36%	1,350	55	Mild	
9	Even Distribution	1,675	1,900	1,660	74%	2,490	23	Severe	✓
10				1,900	85%	2,850	23		
11			2,100	1,660	74%	2,490	23		✓
12				2,100	94%	3,150	23		
13		1,875	1,900	1,660	66%	2,490	23		✓
14				1,900	76%	2,850	23		
15			2,100	1,660	66%	2,490	23		✓
16				2,100	84%	3,150	23		

<sup>1</sup>1,660 vphpl is the demand based on the “Alt A” forecast; 1,900 vphpl is the assumed lower threshold for the capacity of the on-land approaches to the tunnel; 2,100 is the assumed higher threshold for the capacity of the on-land approaches to the tunnel

<sup>2</sup>Ratio of volume in tunnel lane to tunnel lane capacity

<sup>3</sup>Vehicles assumed to utilize (fill) capacity in left-most travel lanes first to avoid downstream merging from right-hand side

---

Figure 6 depicts how the fundamental speed-flow diagram for the eastbound I-64 tunnel entrance was utilized to “model” the anticipated vehicular speed impacts associated with the downstream merging maneuvers. Specifically, departing the tunnels, motorists are likely to be traveling close to or at a free-flow speed of about 62 mph (see Position A in Figure 6). If the downstream merging maneuvers are relatively infrequent and well-orchestrated in unison (e.g., sequential lane changes from right-to-left across the roadway), then the downstream speed will likely drop to about 55 mph (see Position B in Figure 6). The resulting deceleration “shockwave” will attempt to travel upstream into the tunnel; however, the “shockwave” will be dissipated by significantly longer vehicle headways in the tunnel (i.e., congestion and braking will be minimal). As a result, there will be very little “accordion effect” and congestion if the downstream merging volumes are relatively low.

If the downstream lane reduction merging volumes are high (see Figure 4) and, consequently, there is a lot of turbulence and friction as motorists depart the tunnel and abruptly work their way from right-to-left across the roadway, then the downstream travel speed will likely decrease to about 23 mph (see Position C in Figure 6) due to individual lanes temporarily exceeding capacity. In this instance, the resulting deceleration “shockwave” will be very severe and it will travel upstream through the initially uncongested tunnel lanes. Further, motorists within the tunnel will likely be exposed to a rather noticeable “accordion effect,” including very abrupt braking, which has significant safety implications especially within a confined roadway segment such as a tunnel. It is important to note that these simplified schematics depict motorists changing lanes in unison which is overly optimistic as it is likely that the lane changing will occur in several stages in the vicinity of the merge point.

This planning-level assessment provides an approximation of the anticipated speeds based on assumptions regarding the ability for motorists to merge at the downstream end of the tunnel. The exact amount of lane changing that can be accommodated without significantly degrading traffic operations is unknown. However, it can be reasonably assumed that the calculated number of lane changes ranging from 2,490 to 3,150 vph associated with assuming even distribution of traffic between the tunnel lanes (i.e., Scenarios 9 through 16 in Table 2) will significantly degrade operations at the downstream end of the tunnels with the 3 – 4 – 3 Concept.

It should be noted that when a travel lane is added along a facility, motorists have a natural tendency to utilize available (unoccupied) lane capacity especially in high-volume corridors approaching at-capacity conditions such as the I-64 corridor during peak periods. As a result, conditions similar to those depicted in Scenarios 9 through 16 in Table 2 are much more likely than Scenarios 1 through 8 which assume an extreme bias toward motorists staying to the left to avoid the downstream merge condition. As indicated, all “even distribution” scenarios result in severe congestion due to the downstream lane reduction beyond the tunnel. Another conclusion that can be drawn is that five of the eight “left-hand-lane bias” scenarios result in less than a 5-percent utilization of the fourth tunnel lane. As noted above, motorists will likely have a natural tendency to attempt to utilize the fourth lane; however, these five scenarios illustrate that a fourth tunnel lane is minimally justified to accommodate anticipated approach traffic demand.

Scenarios 2 and 8 are the only two scenarios with a reasonable usage of the fourth tunnel lane (i.e., greater than 5 percent) while also resulting in mild or unchanged congestion levels. However, these two scenarios reflect the exaggerated “left-hand-lane bias” tunnel utilization, which are unlikely to be realized under “real-world” conditions due to motorists’ natural tendency to utilize available lane capacity (i.e., the fourth tunnel lane). Consequently, Scenarios 2 and 8 will effectively regress (converge) to Scenarios 10 and 16, respectively, which have severely degraded anticipated congestion levels due to extensive downstream merging and lane changing maneuvers.



**Figure 6: Speed-Flow Diagram Showing Anticipated Downstream Merging Impacts**

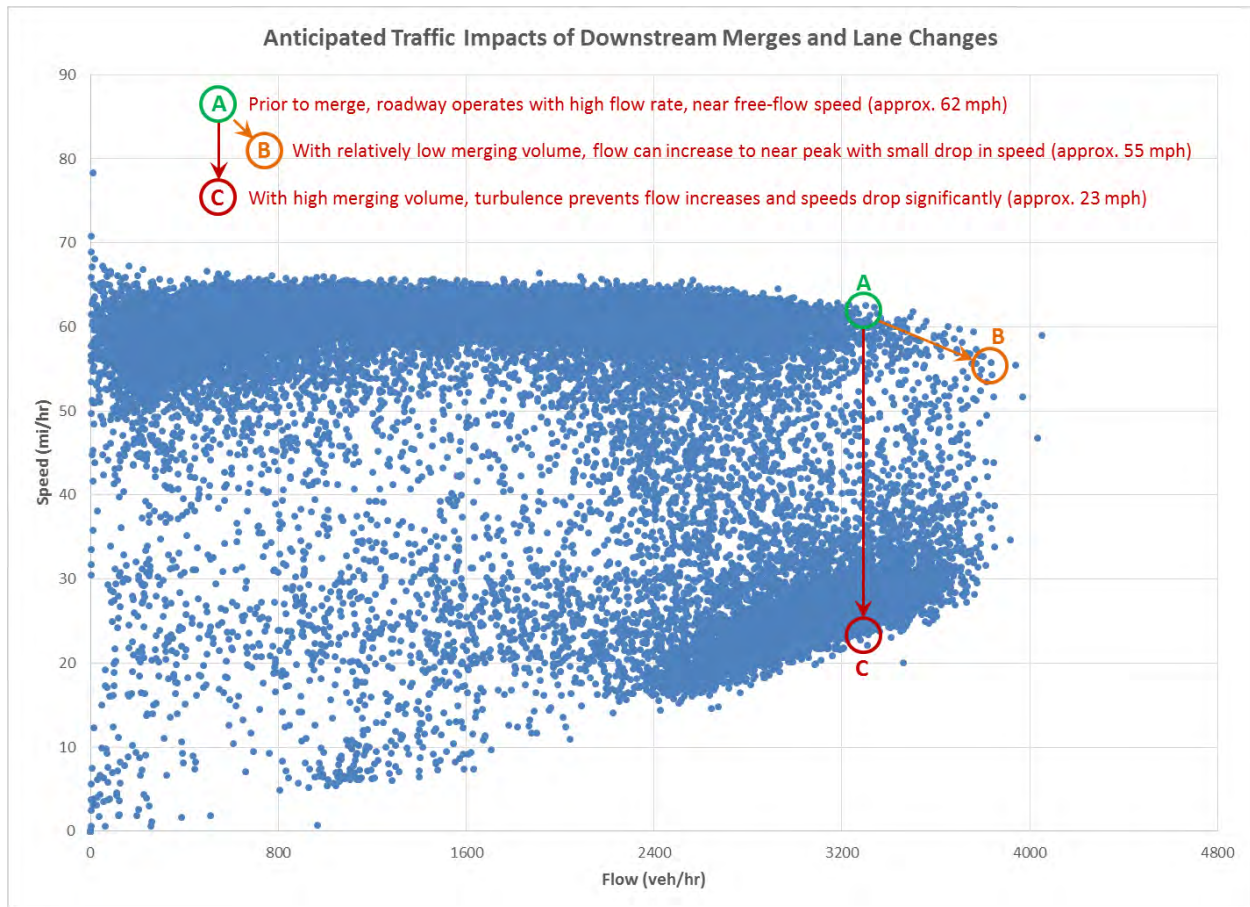

## 5. SAFETY ASSESSMENT

Based on a review of the *Highway Safety Manual (HSM)* and FHWA’s Crash Modification Factors Clearinghouse<sup>2</sup>, there are no available crash modification factors (CMFs) that specifically relate to the 3 – 4 – 3 Concept. Additionally, there are no CMFs for merge and diverge junctions. Therefore, various elements of the 3 – 4 – 3 Concept were investigated to determine their potential positive or negative impacts on safety.

Anecdotally, crashes along freeway facilities tend to occur at locations where drivers must make a choice and/or perform a driving maneuver (as opposed to continuing along the through traveled way). Merges and diverges are two examples of these locations which tend to experience higher crash frequencies. The 3 – 4 – 3 Concept introduces a major diverge (major fork) on the approach to the tunnel and a major merge point (branch connection) beyond the tunnel exit. Therefore, it can be presumed that this design could potentially result in more crashes than a design with a continuous cross section without merge and diverge points.

<sup>2</sup> Crash Modification Factors Clearinghouse. Federal Highway Administration, accessed March 30, 2016, <http://www.cmfclearinghouse.org/>



---

The literature review contained in *Safety Prediction Methodology and Analysis Tool for Freeways and Interchanges*<sup>3</sup> discusses the impact of freeway ramp entrances and exits and lane changing behavior on crash experience. Although the diverge and merge junctions associated with the 3 – 4 – 3 Concept are not identical to a freeway entrance or exit ramp, the resulting lane changing behavior will operate similar to entrance and exit ramps. Studies performed to examine the influence of interchange ramps on freeway crash experience found crash rate increases of approximately 200 percent compared to non-interchange segments (defined as more than 1,500 feet from the middle of an interchange). Studies have also indicated that crash rates gradually reduce as the distance from the ramp gore increases, which is likely due to the lane-changing behavior that increases in the vicinity of the ramp.

The merge and diverge points are discussed further below.

**Three-Lane to Four-Lane Diverge (Major Fork) on Tunnel Approaches:** On the proposed tunnel approach, a three-lane cross section will be expanded to a four-lane cross section. Drivers traveling in the middle lane will be required to make a choice to enter the inner-most lane of either tube of the tunnel. Drivers traveling across long bridge structures, particularly those over scenic waterways, may have a tendency to be more distracted than those traveling on a more traditional section of roadway. Therefore, requiring drivers to make this lane choice while traveling on the bridge raises some safety concerns. Per the Green Book, “the rate of crashes in gore areas is typically greater than the rate of run-off-the road crashes at other locations.” Crashes or incidents at the physical gore or diverge point could result in a complete closure of the tunnel, which could have a significant impact on traffic flow in the region due to the importance of the facility.

**Four-Lane to Three-Lane Lane Reduction Downstream of Tunnel:** Downstream of the tunnel, the four-lane section from the tunnel is proposed to return to the three-lane cross section. As such, introducing a lane reduction on the bridge structure is proposed in the eastbound direction. The westbound downstream lane reduction could be accomplished by either a left lane or right lane reduction. Per the *HSM*, drivers expect exit and entrance ramps on freeways to be on the right-hand side of the freeway. Furthermore, Chapter 10 of the Green Book states that “a right-side lane reduction has advantages (over a left-side lane reduction) in that speeds are generally lower and the merging maneuver from the right is more familiar to most motorists because it is similar to a merge at an entrance ramp.”

As noted above, the *HSM* does not provide a CMF for merge junctions; however, the *HSM* does provide a CMF of 0.68 for modifying a merge/diverge area from a two-lane change to one-lane change, which suggests that a merge/diverge requiring motorists to change only one lane will experience approximately 32 percent less crashes than a merge/diverge that requires motorists to change two lanes. Although lane changes are not required by motorists on the approach to the tunnel, for the tunnel capacity schematics with relatively even utilization of the tunnel lanes, some motorists at the departure end of the tunnel will likely make two lane changes in an attempt to balance the flows between the travel lanes. The CMF implies that lane changing behavior generally results in increased crash rates. It should be noted that the primary location for the lane changing behavior along eastbound I-64 would be along the trestle section just before the horizontal curve to the left approaching Willoughby Spit. In this area, the consequences of a crash are potentially more severe and there are added difficulties associated with emergency response compared to a crash that might occur on land.

---

<sup>3</sup> Bonneson, J. (2012). NCHRP Project 17-45: Safety Prediction Methodology and Analysis Tool for Freeways and Interchanges. Transportation Research Board, Washington, D.C.

---

## **6. DISCUSSION OF 3 - X - 3 CONCEPT**

The 3 – X – 3 Concept includes a new two-lane tunnel with two reversible lanes depending on the time of day with four lanes in the peak direction and two lanes in the off-peak direction. Similar to the 3 – 4 – 3 Concept, VDOT does not want to pursue the construction of a new tunnel between the existing tunnels as originally suggested for the 3 – X – 3 Concept due to the risk to the existing tunnels that such construction would pose. Therefore, the version of the 3 – X – 3 Concept (see Figure 2) considered as part of this assessment includes a new two-lane tunnel approximately 200 feet southwest of the existing tunnels resulting in a total of six tunnel lanes, with the existing two eastbound lanes (the middle tunnel of three tubes) being operated as reversible lanes depending on the time of day (four lanes in the peak direction; two in the off-peak direction). Gated connections/crossovers would need to be provided on the north (Hampton) end and the south (Norfolk) end in order to operate the middle tube as reversible.

Reversible lane systems are typically considered along facilities with significant directionality during peak periods in order to maximize traffic capacity in the peak direction of travel while maintaining acceptable operations in the non-peak travel direction. Based on a review of the existing and forecasted traffic volumes shown in Table 1, peak hour traffic volumes on the eastbound and westbound approaches to the HRBT are relatively similar under both existing and future conditions. Under existing conditions during the AM peak hour, traffic is relatively evenly distributed between eastbound and westbound I-64 with 51 percent of traffic traveling along eastbound I-64 and 49 percent of traffic traveling along westbound I-64. During the PM peak hour, 52 percent of traffic travels along eastbound I-64 compared to 48 percent of traffic along westbound I-64. Similarly, under future No Build conditions and Alternative A, the peak direction of travel ranges from 50 to 52 percent indicating that traffic volumes traveling through the tunnel will continue to be evenly distributed during peak hours in the future.

The travel direction with four lanes would operate similar to the 3 – 4 – 3 Concept as documented in the preceding sections with both operational and safety issues associated with the merge and diverge junctions at the transition from three lanes to four lanes and then back down to three lanes. The non-peak or unfavored travel direction would effectively operate as a 3 – 2 – 3 configuration with three approach lanes merging down to two tunnel lanes (see Figure 2). Based on the equal distribution of traffic between the eastbound and westbound tunnels, a reversible lane system is not appropriate to accommodate the similar traffic volumes in both directions and the merge from three lanes to two lanes in the unfavored travel direction would result in a bottleneck causing significant delays during peak periods.

## **7. DISCUSSION OF MANAGED LANES SCENARIO**

The current HRCS Build alternatives do not include managed-lane scenarios (e.g., tolling, HOV, etc.) along I-64; however, there is the potential that a managed-lane scenario could be considered in the future for the I-64 corridor. For the new bridge-tunnel, the structures can be designed with sufficient width to accommodate a four-foot buffer strip between the managed and general purpose lanes. For the existing bridges and tunnels, accommodating a managed lane would be more difficult. On the bridge sections, providing a four-foot buffer strip would reduce the right shoulder from approximately ten feet to six feet, otherwise the bridges would have to be widened. Through the tunnel, there would be no buffer strip, but that may be acceptable because the signing and striping, as they exist today, discourage lane changes in the tunnels. By combining managed lanes with the 3 – 4 – 3 Concept, the general purpose lanes would essentially operate as a “2 – 3 – 2” scenario (see Figure 7). This should provide adequate capacity for the general purpose lanes through the tunnels.

**Figure 7: Conceptual Layout of 3 – 4 – 3 Managed Lanes Configuration**

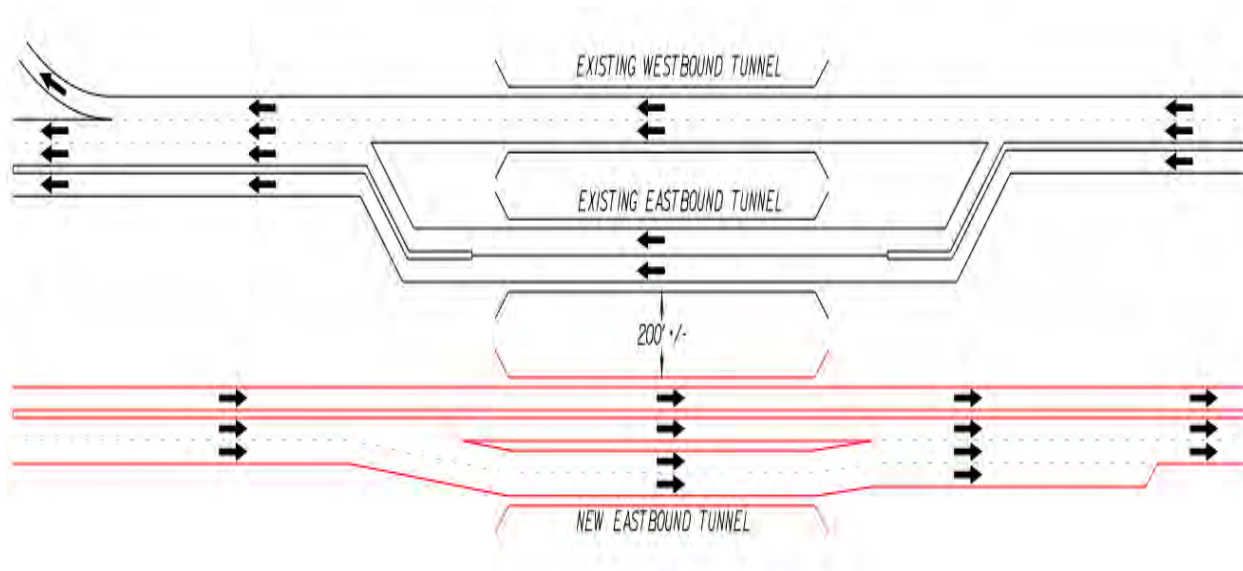

## 8. CONCLUSION

The 3 – 4 – 3 Concept was presented by the Hampton Roads Transportation Planning Organization (HRTPO) as a potential option to provide capacity improvements while confining improvements along the I-64 corridor largely within existing right of way. Planning-level speed-flow diagrams were utilized to predict anticipated vehicular speeds associated with the merging maneuvers resulting from lane reduction from four to three lanes at the downstream ends of the tunnels. Assuming an even distribution of traffic between the tunnel lanes, the 3 – 4 – 3 Concept will result in severely degraded congestion levels due to extensive merging and lane changing maneuvers at the downstream end of the tunnels. Additionally, higher crash rates along freeway facilities typically occur at locations where drivers must make a choice and/or perform a driving maneuver. Therefore, it can be presumed that the 3 – 4 – 3 Concept could potentially result in more crashes than a design with a continuous cross section without merge and diverge points.

With the exception of the additional tunnel and bridge lane that would be constructed with the 3 – 4 – 3 Concept, impacts associated with the 3 – 4 – 3 Concept would be similar to the 3 – 3 – 3 Concept (Alternative A of the Draft SEIS) and are documented in Section 3 of the Draft SEIS. The 3 – 4 – 3 Concept would result in a commensurate increase to the environmental impacts, specifically the water resources calculated for Alternative A (see Section 3.8.1 of the draft SEIS) due to the additional tunnel and bridge width. The 3 – 4 – 3 Concept would result in a 15 to 20 increase to the tunnel cost compared to the tunnel costs identified in the Draft SEIS for Alternative A.

Although the 3 – 4 – 3 Concept is not included as a formal alternative in the draft SEIS, it could be incorporated into any alternative that includes improvements to the I-64 Study Area Corridor if there is a desire to assess the need for increased capacity of the HRBT compared to the approach roadways. Additionally, if the 3 – 4 – 3 Concept is identified as part of the preferred alternative, it would be analyzed in greater detail in the Final SEIS, including an assessment of cost and impacts.

**ATTACHMENT A: 3 – 4 – 3 Concept Layout**

**ATTACHMENT B: Fundamental Traffic Flow Diagrams**

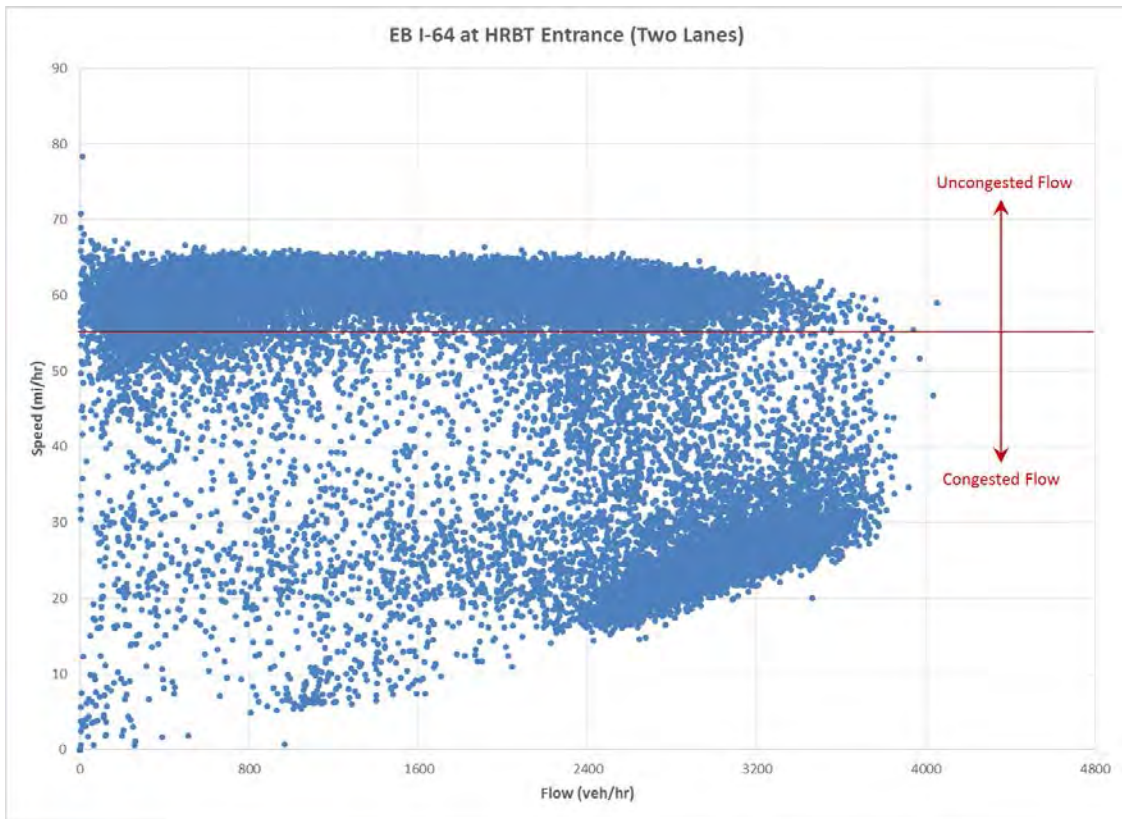
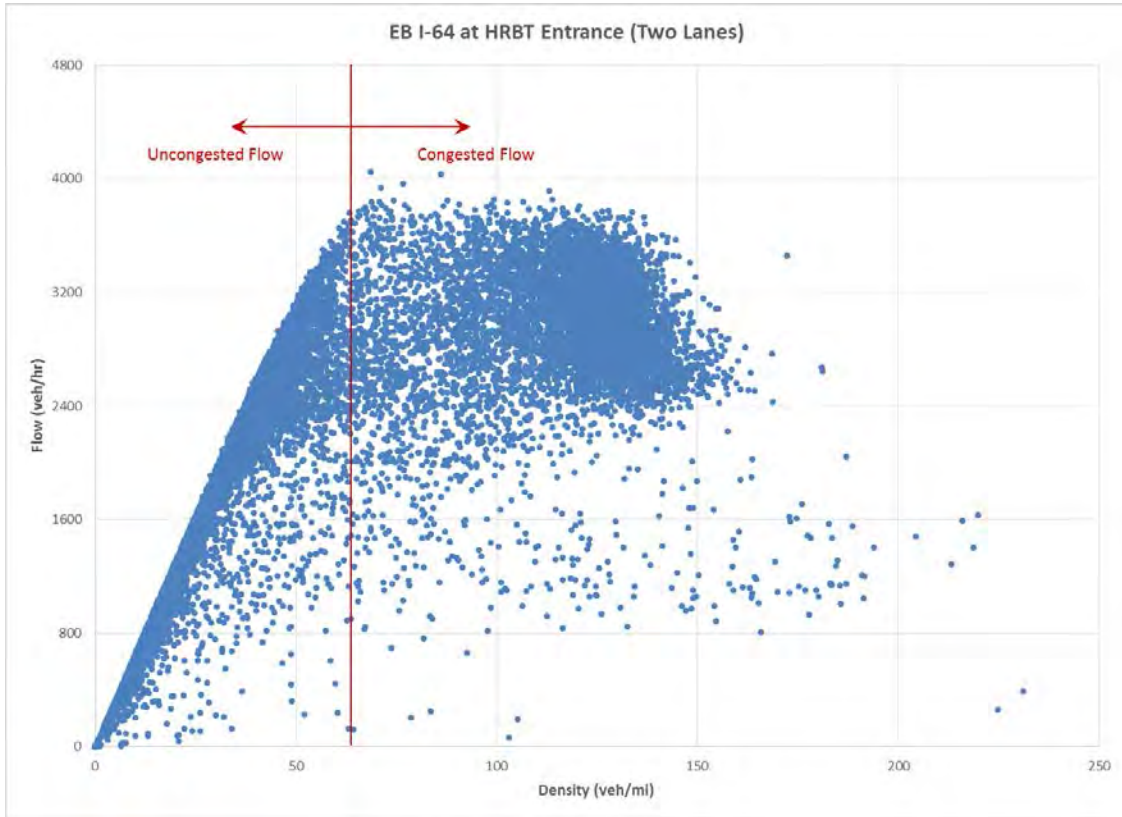

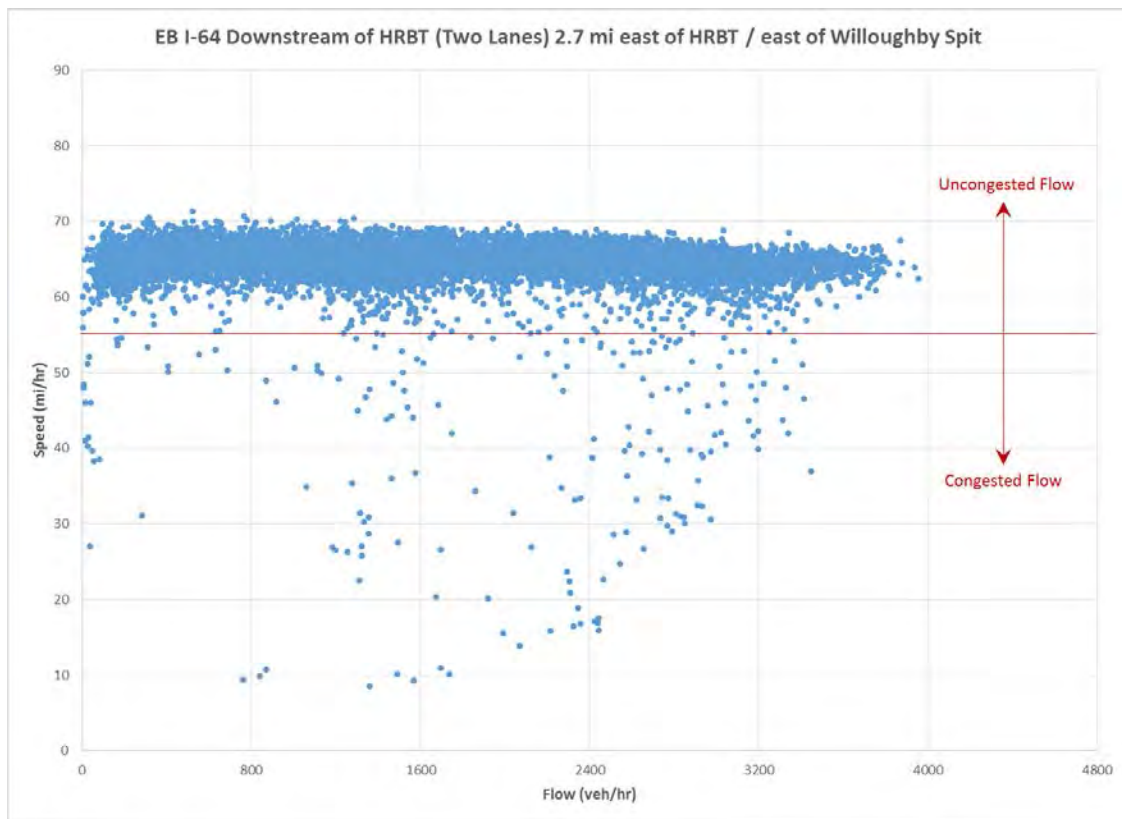
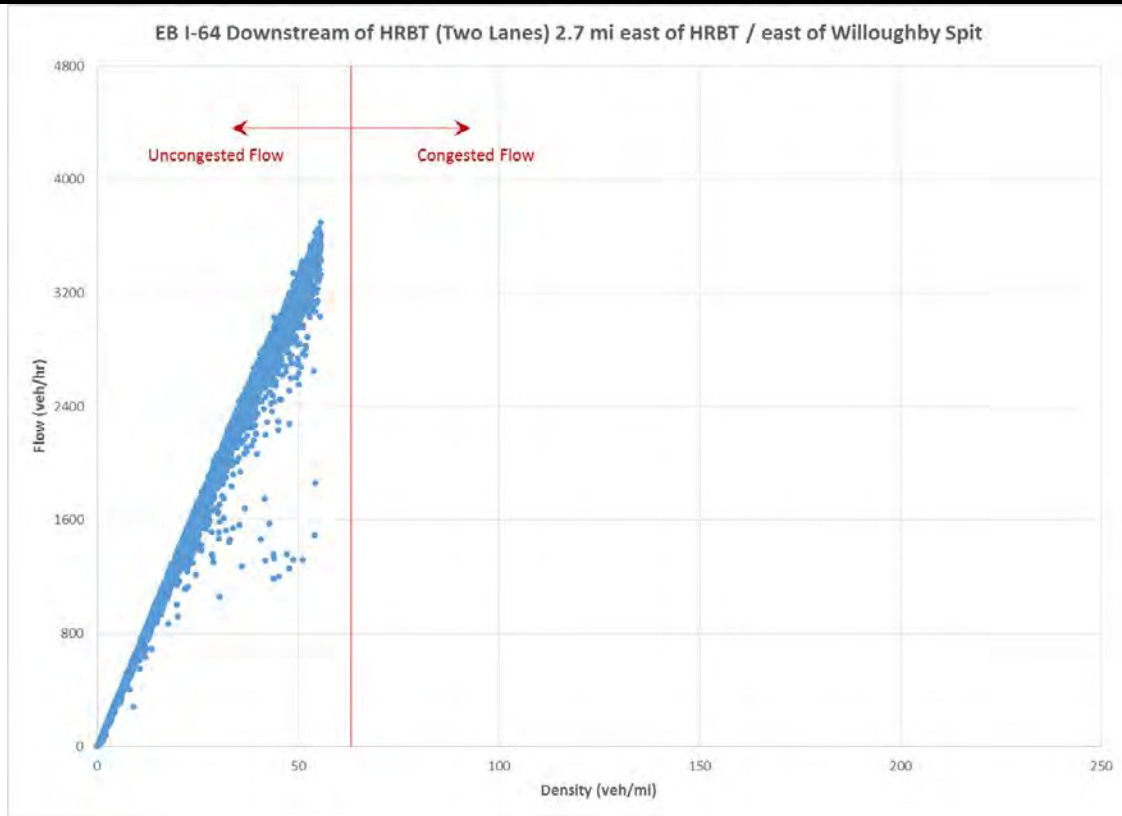

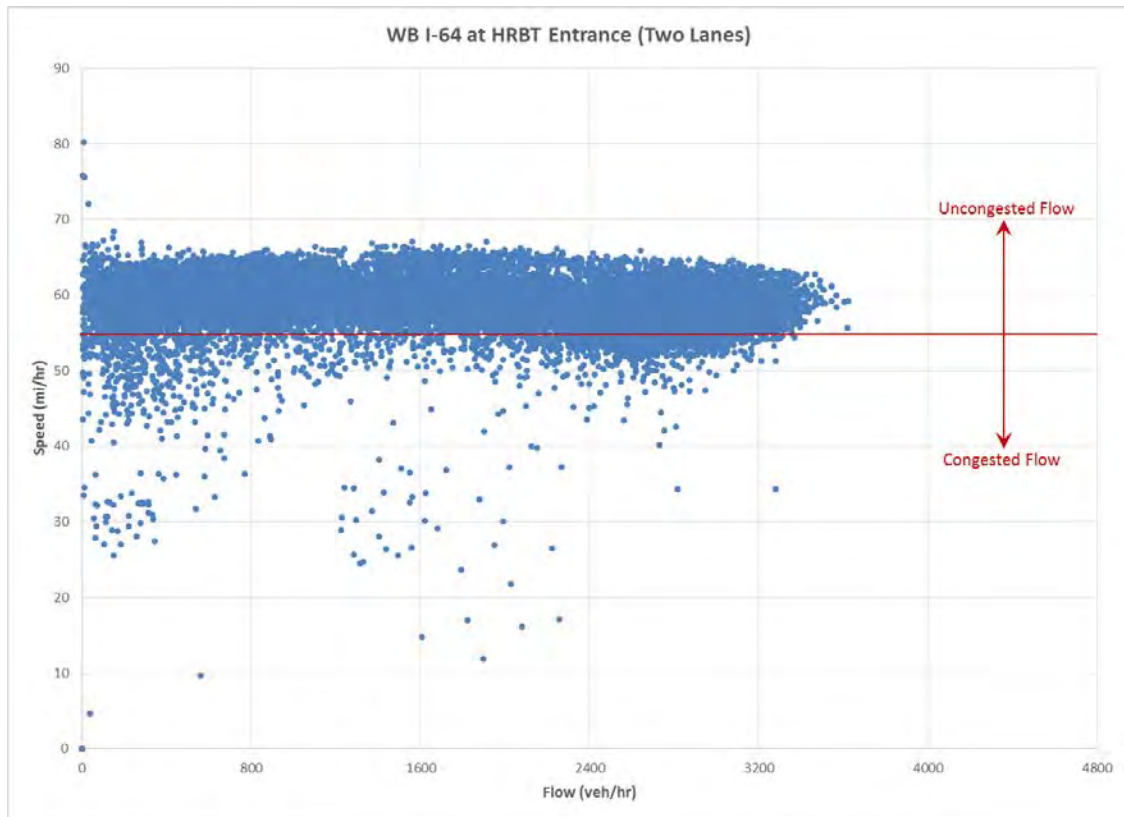
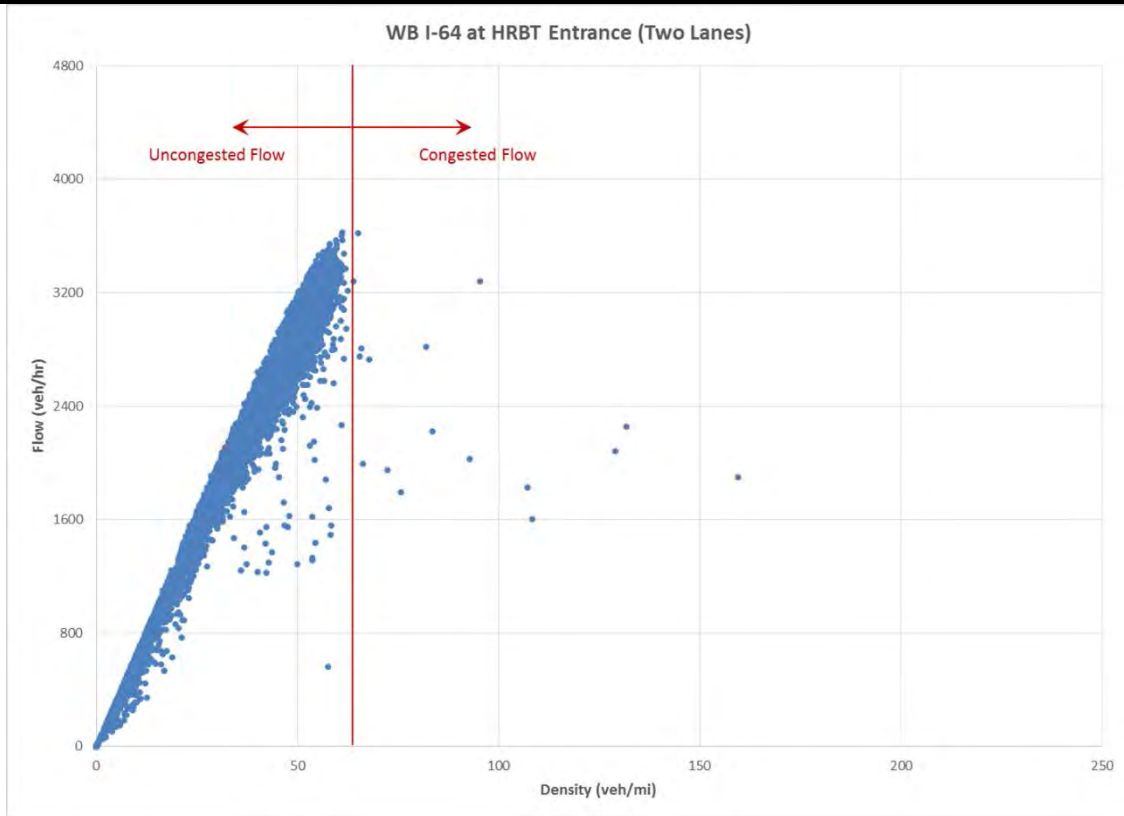



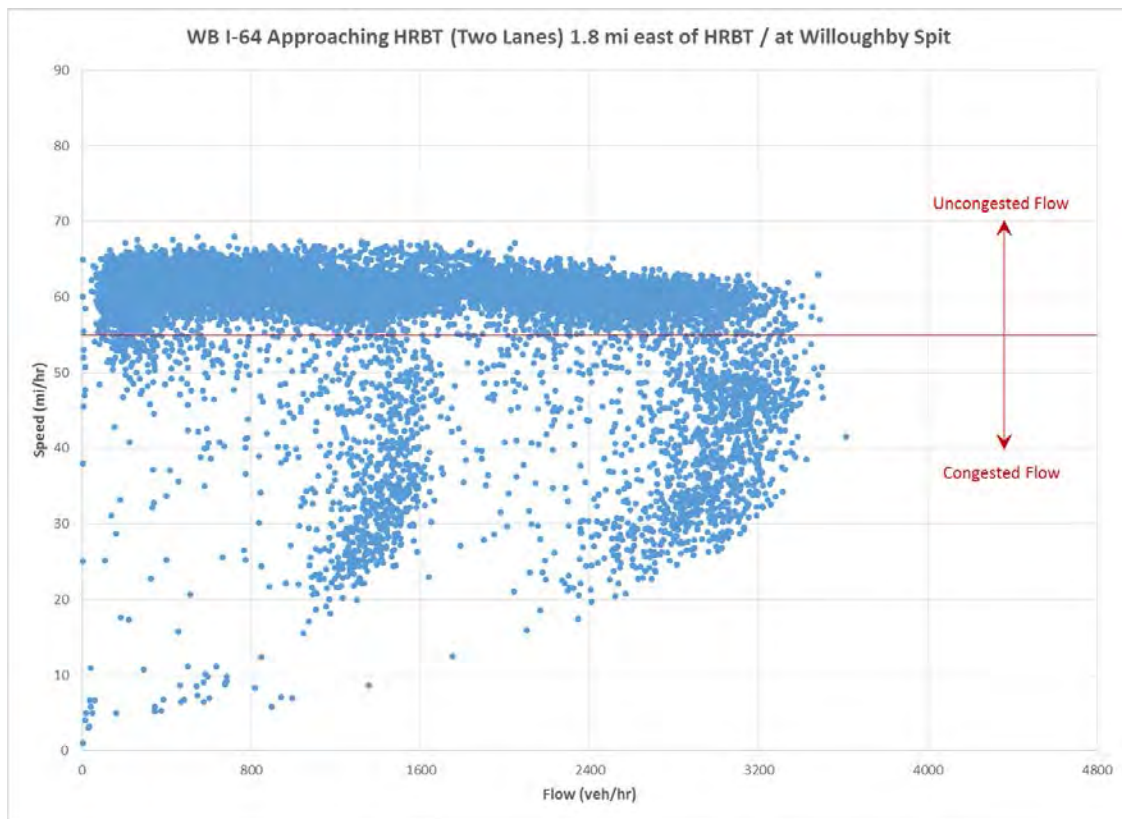
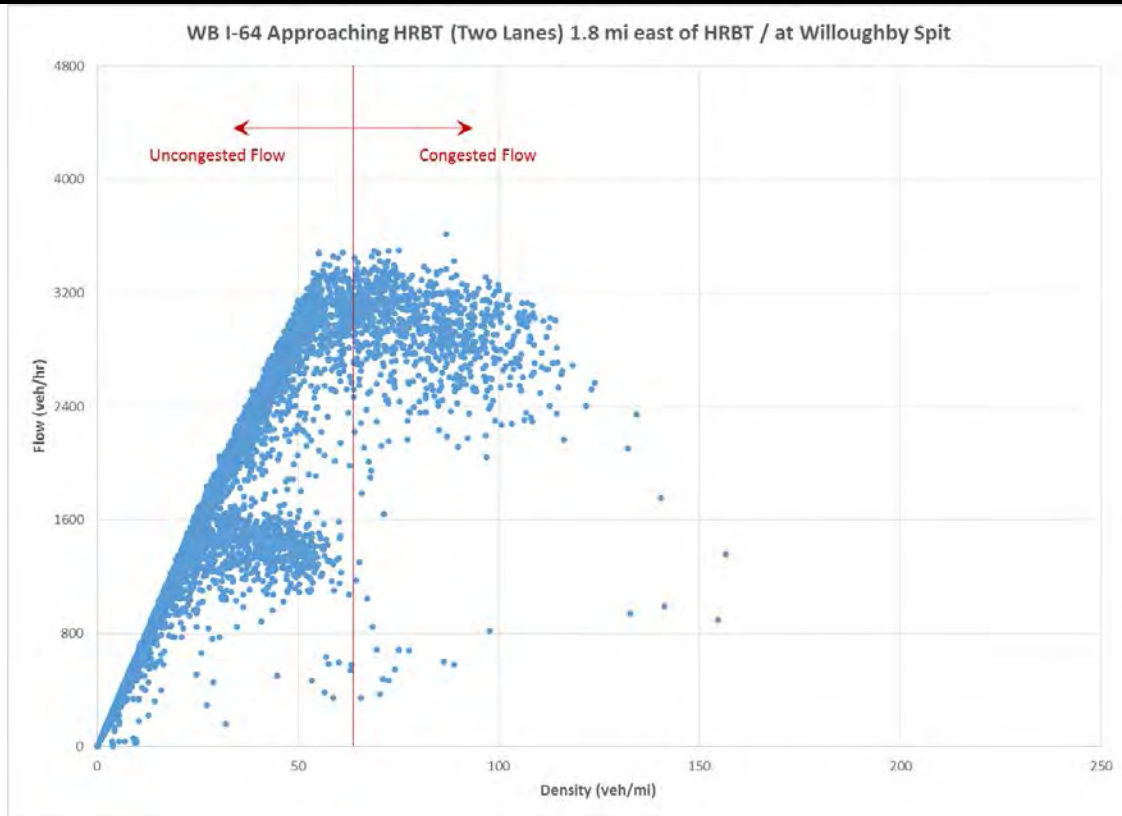

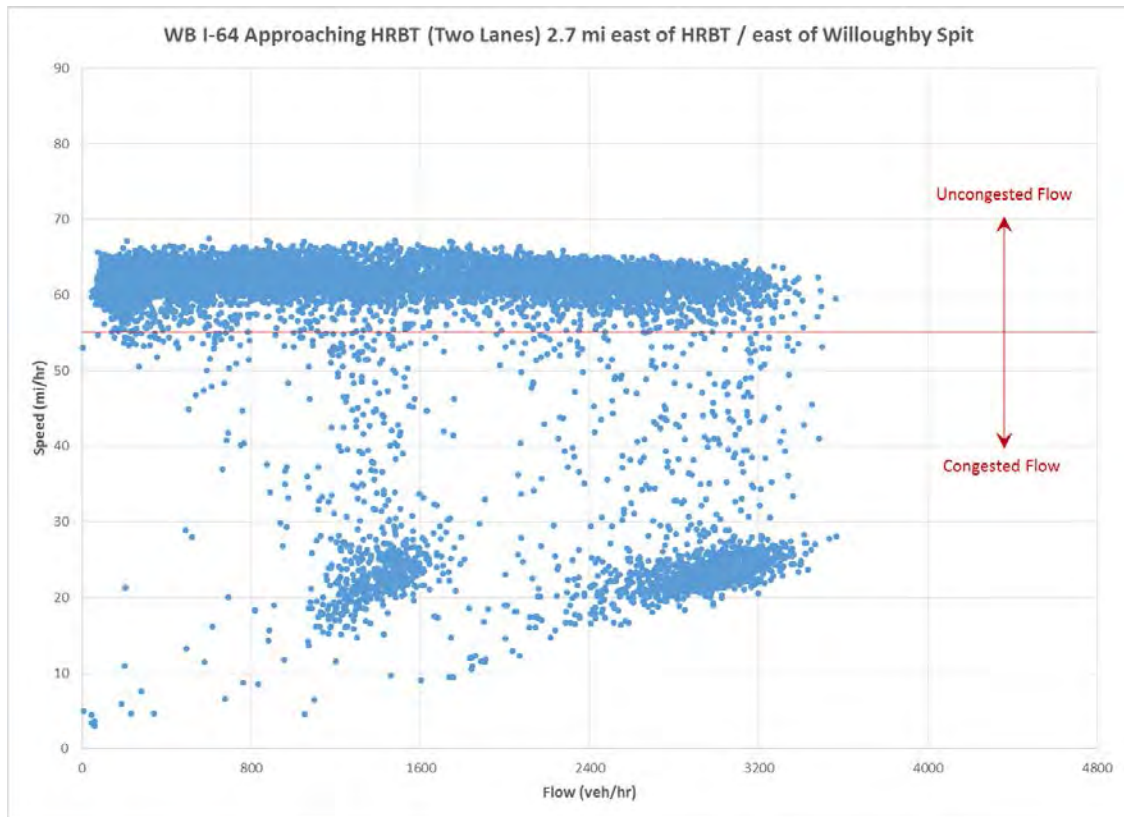
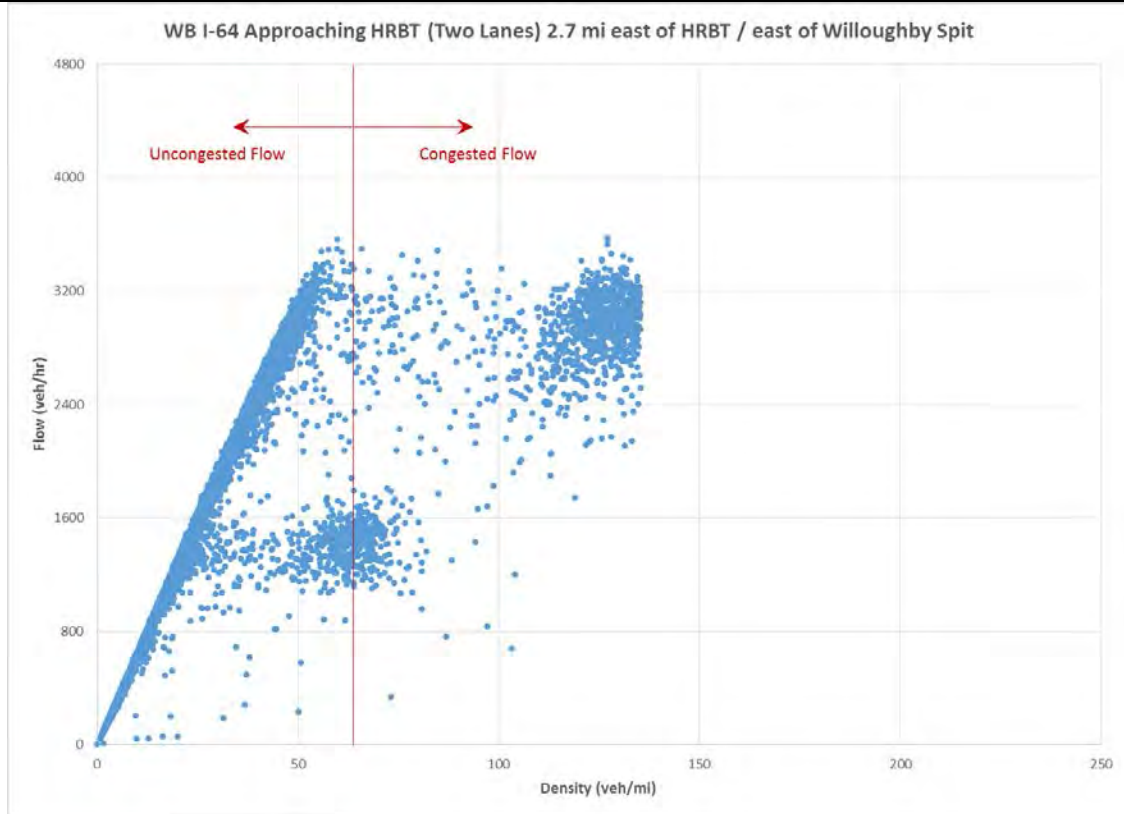

**ATTACHMENT C: Lane Volume Schematics for Sensitivity Analysis**

**Tunnel Lane Utilization and Downstream Merging Impacts Scenario 1**

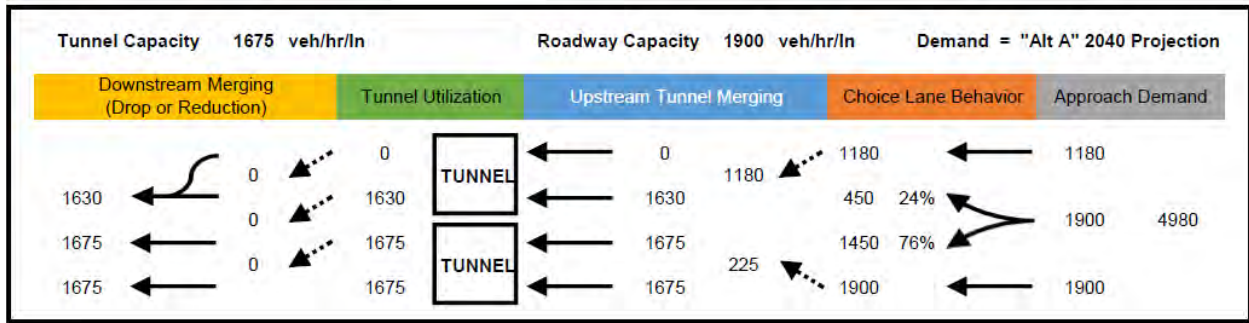

**Tunnel Lane Utilization and Downstream Merging Impacts Scenario 2**

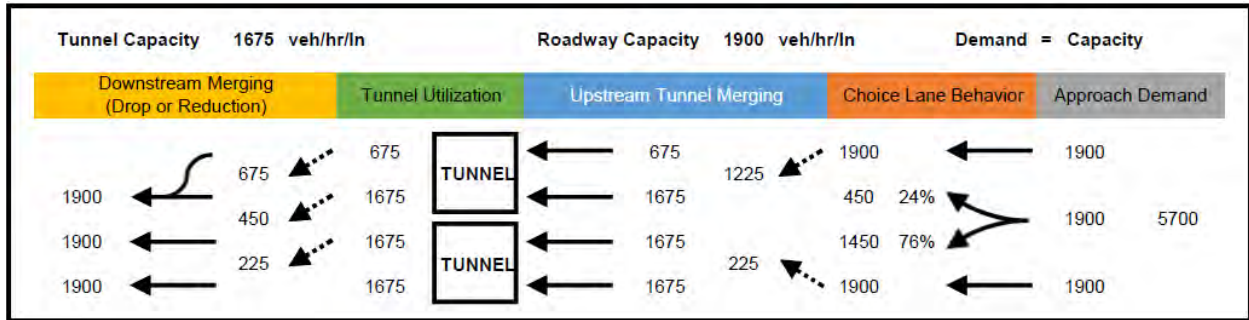

**Tunnel Lane Utilization and Downstream Merging Impacts Scenario 3**

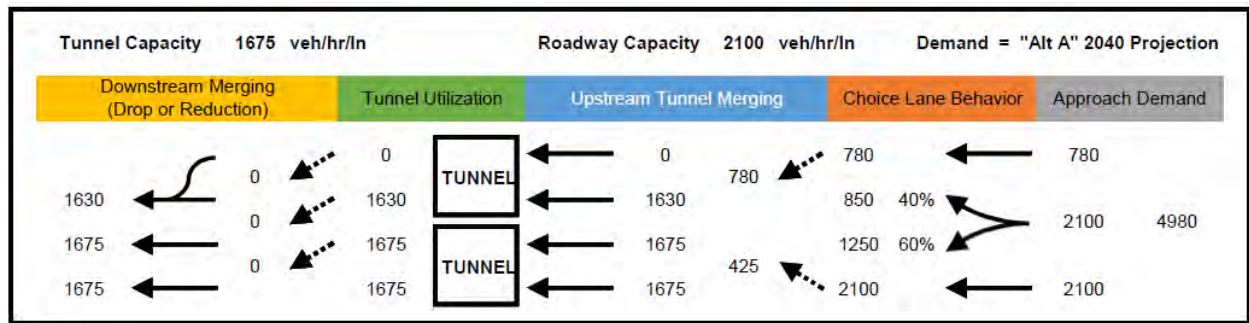

**Tunnel Lane Utilization and Downstream Merging Impacts Scenario 4**

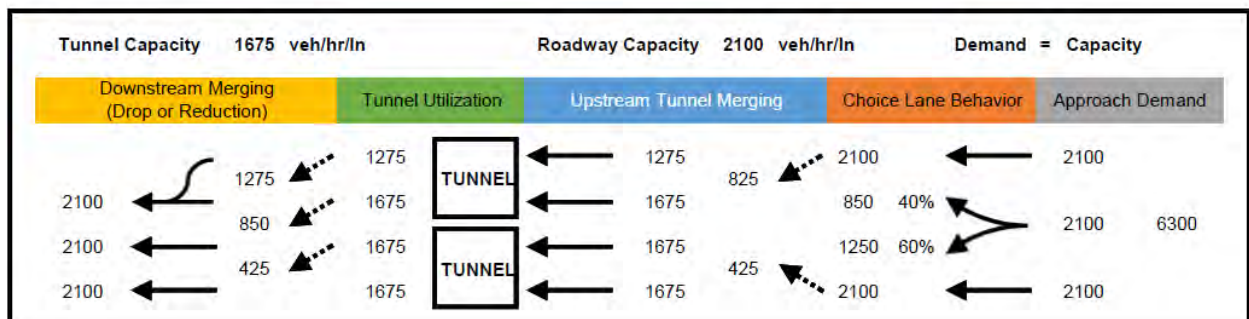

**Tunnel Lane Utilization and Downstream Merging Impacts Scenario 5**

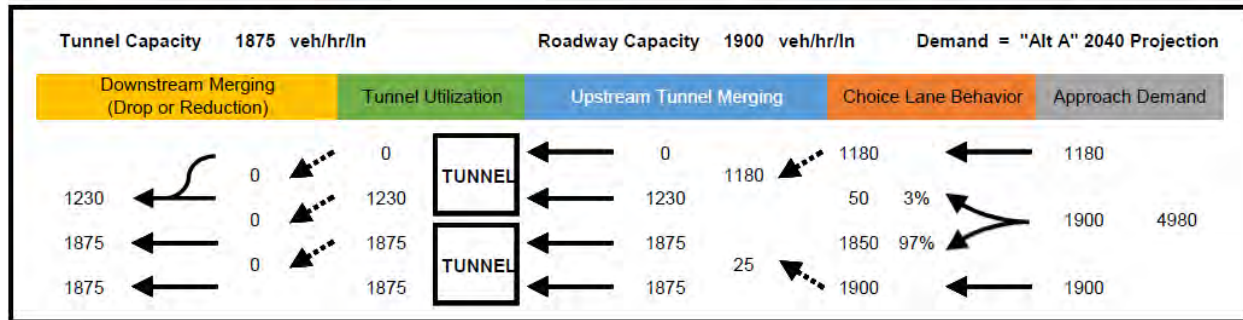

**Tunnel Lane Utilization and Downstream Merging Impacts Scenario 6**

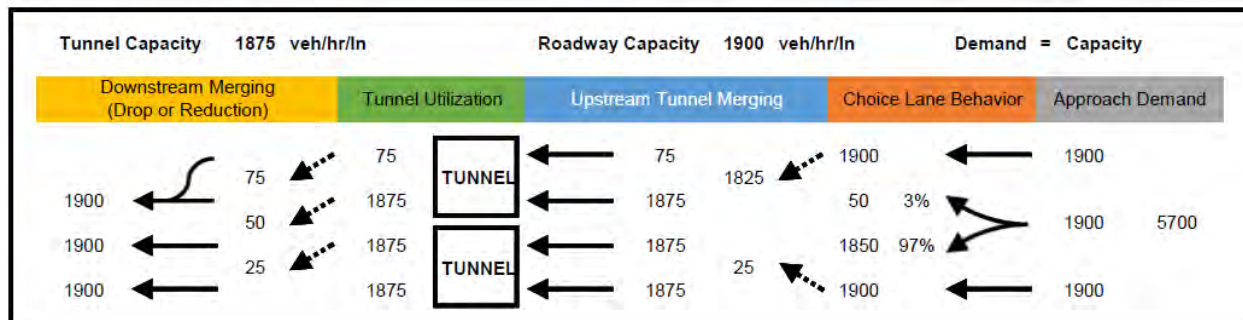

**Tunnel Lane Utilization and Downstream Merging Impacts Scenario 7**

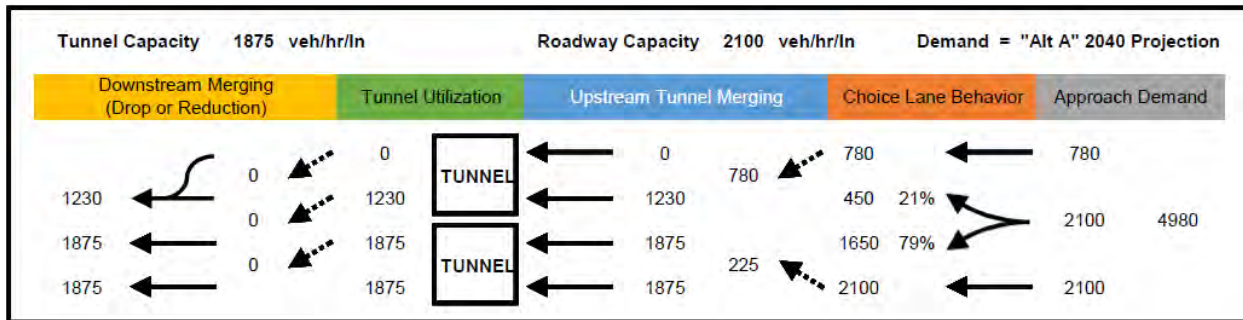

**Tunnel Lane Utilization and Downstream Merging Impacts Scenario 8**

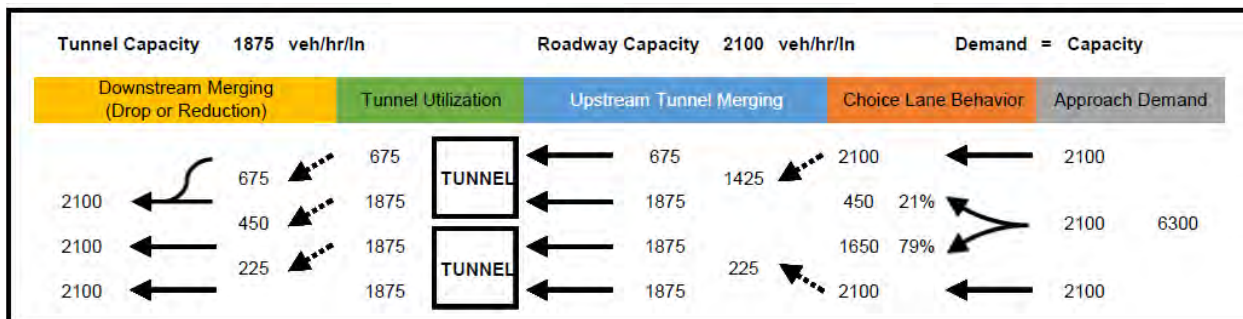

**Tunnel Lane Utilization and Downstream Merging Impacts Scenario 9**

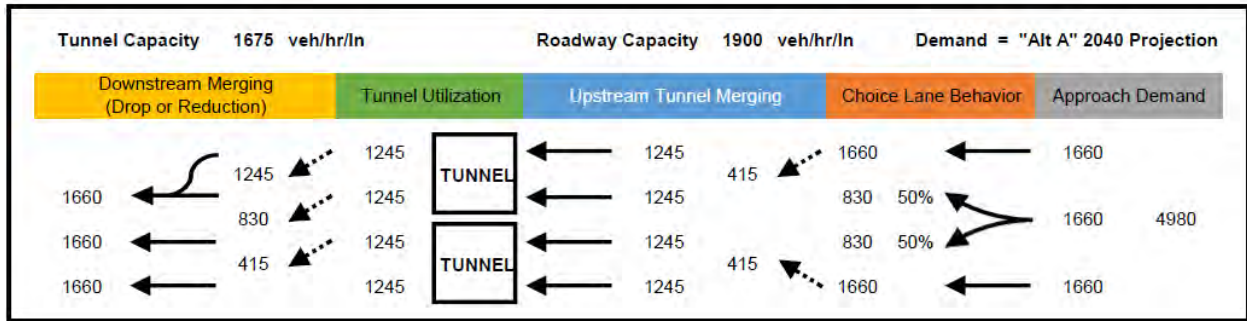

**Tunnel Lane Utilization and Downstream Merging Impacts Scenario 10**

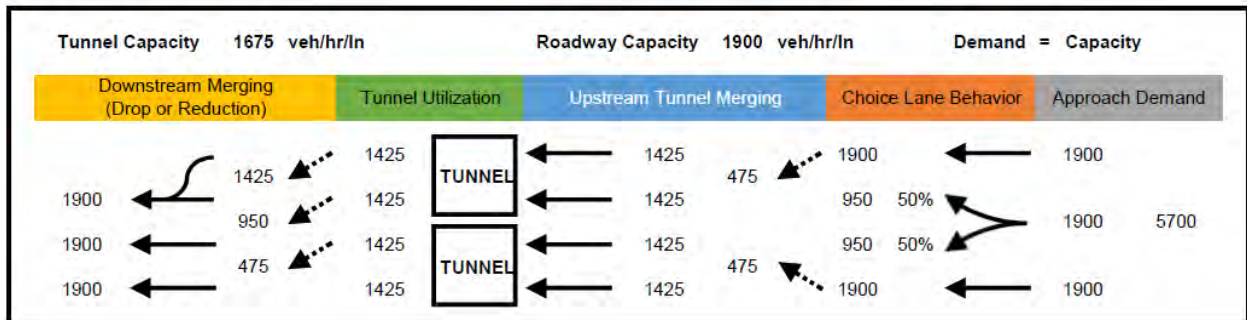

**Tunnel Lane Utilization and Downstream Merging Impacts Scenario 11**

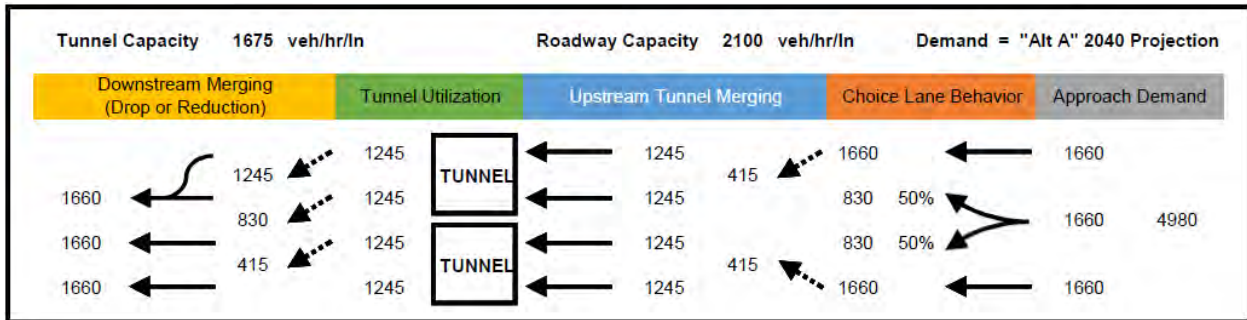

**Tunnel Lane Utilization and Downstream Merging Impacts Scenario 12**

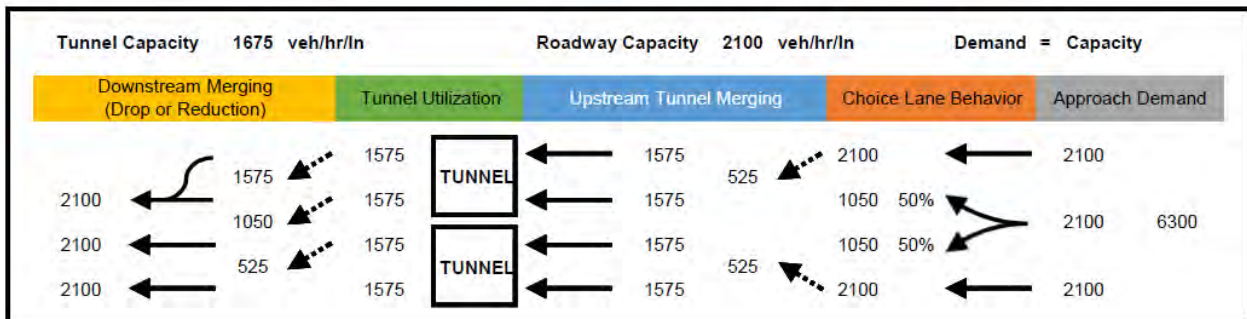

**Tunnel Lane Utilization and Downstream Merging Impacts Scenario 13**

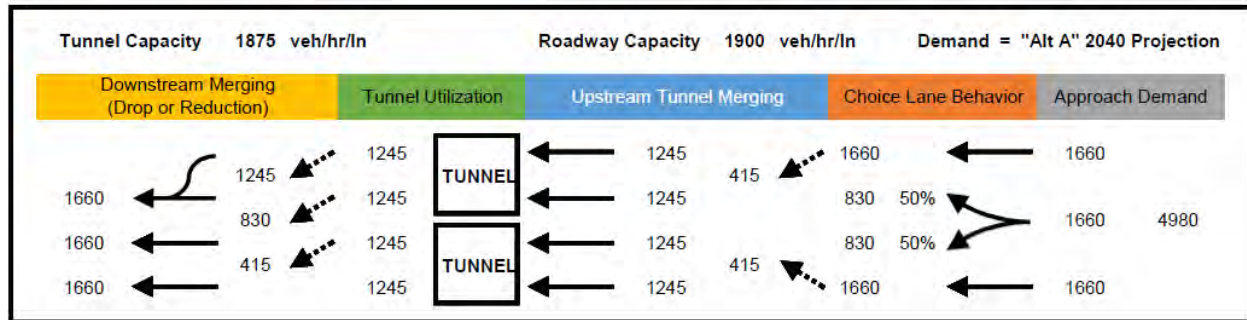

**Tunnel Lane Utilization and Downstream Merging Impacts Scenario 14**

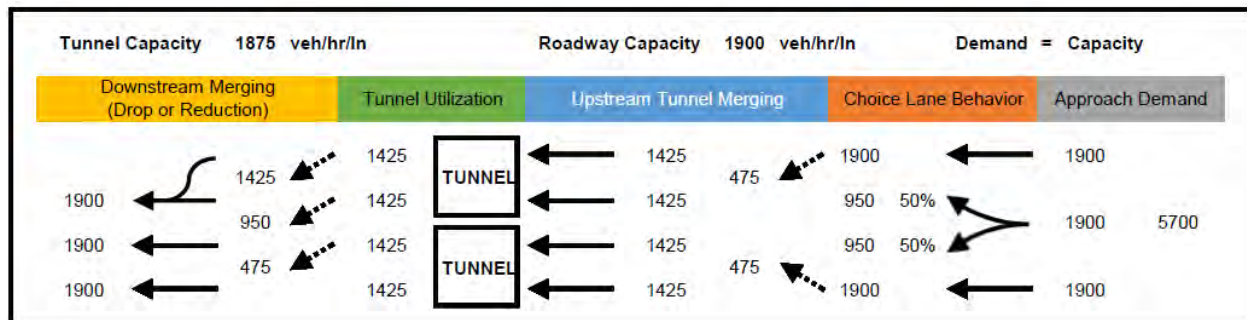

**Tunnel Lane Utilization and Downstream Merging Impacts Scenario 15**

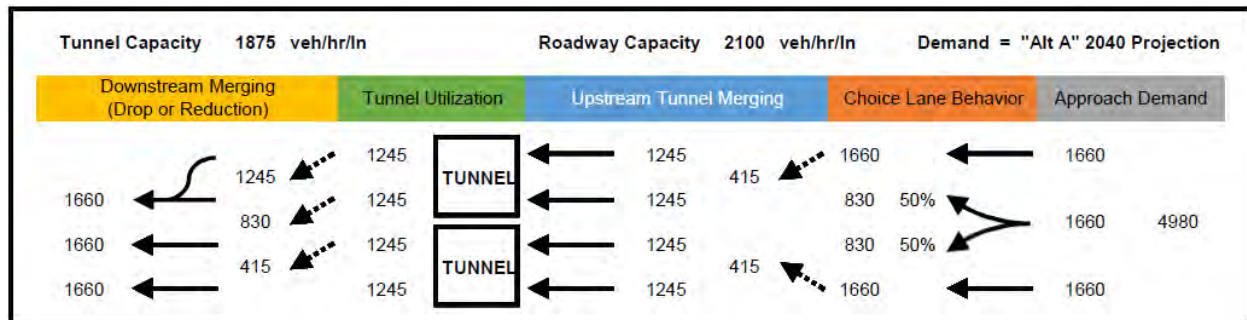

**Tunnel Lane Utilization and Downstream Merging Impacts Scenario 16**

